



Operation and Maintenance Manual

300.9D and 300.9D VPS Mini Hydraulic Excavator

LJM 1-UP (300.9D)
LJ2 1-UP (300.9D)
DW2 1-UP (300.9D VPS)
TGP 1-UP (300.9D VPS)

Language: Original Instructions

Important Safety Information

Most accidents that involve product operation, maintenance and repair are caused by failure to observe basic safety rules or precautions. An accident can often be avoided by recognizing potentially hazardous situations before an accident occurs. A person must be alert to potential hazards, including human factors that can affect safety. This person should also have the necessary training, skills and tools to perform these functions properly.

Improper operation, lubrication, maintenance or repair of this product can be dangerous and could result in injury or death.

Do not operate or perform any lubrication, maintenance or repair on this product, until you verify that you are authorized to perform this work, and have read and understood the operation, lubrication, maintenance and repair information.

Safety precautions and warnings are provided in this manual and on the product. If these hazard warnings are not heeded, bodily injury or death could occur to you or to other persons.

The hazards are identified by the "Safety Alert Symbol" and followed by a "Signal Word" such as "DANGER", "WARNING" or "CAUTION". The Safety Alert "WARNING" label is shown below.



The meaning of this safety alert symbol is as follows:

Attention! Become Alert! Your Safety is Involved.

The message that appears under the warning explains the hazard and can be either written or pictorially presented.

A non-exhaustive list of operations that may cause product damage are identified by "NOTICE" labels on the product and in this publication.

Caterpillar cannot anticipate every possible circumstance that might involve a potential hazard. The warnings in this publication and on the product are, therefore, not all inclusive. You must not use this product in any manner different from that considered by this manual without first satisfying yourself that you have considered all safety rules and precautions applicable to the operation of the product in the location of use, including site-specific rules and precautions applicable to the worksite. If a tool, procedure, work method or operating technique that is not specifically recommended by Caterpillar is used, you must satisfy yourself that it is safe for you and for others. You should also ensure that you are authorized to perform this work, and that the product will not be damaged or become unsafe by the operation, lubrication, maintenance or repair procedures that you intend to use.

The information, specifications, and illustrations in this publication are on the basis of information that was available at the time that the publication was written. The specifications, torques, pressures, measurements, adjustments, illustrations, and other items can change at any time. These changes can affect the service that is given to the product. Obtain the complete and most current information before you start any job. Cat dealers have the most current information available.

NOTICE

When replacement parts are required for this product Caterpillar recommends using original Caterpillar® replacement parts.

Other parts may not meet certain original equipment specifications.

When replacement parts are installed, the machine owner/user should ensure that the machine remains in compliance with all applicable requirements.

In the United States, the maintenance, replacement, or repair of the emission control devices and systems may be performed by any repair establishment or individual of the owner's choosing.

Table of Contents

Foreword	4	General Information	33
Safety Section		Identification Information	42
Safety Messages	6	Operation Section	
General Hazard Information	14	Before Operation	48
Crushing Prevention and Cutting Prevention..	17	Machine Operation	50
Burn Prevention.....	17	Engine Starting	75
Fire Prevention and Explosion Prevention	18	Operation.....	77
Fire Extinguisher Location.....	21	Operating Techniques	79
Track Information	21	Parking	87
Electrical Storm Injury Prevention	21	Transportation Information	90
Before Starting Engine	22	Towing Information	95
Visibility Information	22	Engine Starting (Alternate Methods).....	96
Engine Starting	23	Maintenance Section	
Before Operation	23	Maintenance Access	98
Work Tools.....	23	Lubricant Viscosities and Refill Capacities	99
Operation.....	24	Maintenance Support	103
Engine Stopping	27	Maintenance Interval Schedule.....	108
Lifting Objects.....	27	Warranty Section	
Parking	27	Warranty Information.....	139
Slope Operation	28	Reference Information Section	
Equipment Lowering with Engine Stopped	28	Reference Materials	140
Sound Information and Vibration Information .	29	Index Section	
Operator Station	31	Index.....	142
Guards (Operator Protection)	31		
Product Information Section			

Foreword

California Proposition 65 Warning

Diesel engine exhaust and some of its constituents are known to the State of California to cause cancer, birth defects, and other reproductive harm.



WARNING – This product can expose you to chemicals including ethylene glycol, which is known to the State of California to cause birth defects or other reproductive harm. For more information go to:

www.P65Warnings.ca.gov

Do not ingest this chemical. Wash hands after handling to avoid incidental ingestion.



WARNING – This product can expose you to chemicals including lead and lead compounds, which are known to the State of California to cause cancer, birth defects, or other reproductive harm. For more information go to:

www.P65Warnings.ca.gov

Wash hands after handling components that may contain lead.

Literature Information

This manual should be stored in the operator's compartment in the literature holder or seat back literature storage area.

This manual contains safety information, operation instructions, transportation information, lubrication information, and maintenance information.

Some photographs or illustrations in this publication show details or attachments that can be different from your machine. Guards and covers might have been removed for illustrative purposes.

Continuing improvement and advancement of product design might have caused changes to your machine which are not included in this publication. Read, study, and keep this manual with the machine.

Whenever a question arises regarding your machine, or this publication, please consult your Cat dealer for the latest available information.

Safety

The safety section lists basic safety precautions. In addition, this section identifies the text and locations of warning signs and labels used on the machine.

Read and understand the basic precautions listed in the safety section before operating or performing lubrication, maintenance, and repair on this machine.

Operation

The operation section is a reference for the new operator and a refresher for the experienced operator. This section includes a discussion of gauges, switches, machine controls, attachment controls, transportation, and towing information.

Photographs and illustrations guide the operator through correct procedures of checking, starting, operating, and stopping the machine.

Operating techniques outlined in this publication are basic. Skill and techniques develop as the operator gains knowledge of the machine and its capabilities.

Maintenance

The maintenance section is a guide to equipment care. The Maintenance Interval Schedule (MIS) lists the items to be maintained at a specific service interval. Items without specific intervals are listed under the "When Required" service interval. The Maintenance Interval Schedule lists the page number for the step-by-step instructions required to accomplish the scheduled maintenance. Use the Maintenance Interval Schedule as an index or "one safe source" for all maintenance procedures.

Maintenance Intervals

Use the service hour meter to determine servicing intervals. Calendar intervals shown (daily, weekly, monthly, etc.) can be used instead of service hour meter intervals if the calendar intervals provide more convenient servicing schedules and approximate the indicated service hour meter reading. Perform the recommended service at the interval that occurs first.

Under severe, dusty, or wet operating conditions, more frequent lubrication than is specified in the maintenance intervals chart might be necessary.

Perform service on items at multiples of the original requirement. For example, at every 500 service hours or 3 months, also service those items listed under every 250 service hours or monthly and every 10 service hours or daily.

Certified Engine Maintenance

Proper maintenance and repair are essential to keep the engine and machine systems operating correctly. As the heavy-duty off-road diesel engine owner, you are responsible for the performance of the required maintenance listed in the Owner Manual, Operation and Maintenance Manual, and Service Manual.

It is prohibited for any person engaged in the business of repairing, servicing, selling, leasing, or trading engines or machines to remove, alter, or to render inoperative, any emission-related device or element of design installed on or in an engine or machine that is in compliance with all applicable regulations of the intended country to which it has been shipped. Certain elements of the machine and engine such as the exhaust system, fuel system, electrical system, intake air system, and cooling system may be emission-related and should not be altered unless approved by Caterpillar.

Machine Capacity

Additional attachments or modifications may exceed machine design capacity which can adversely affect performance characteristics. Included would be stability and system certifications such as brakes, steering, and rollover protective structures (ROPS). Contact your Cat dealer for further information.

Product Identification Number

Effective First Quarter 2001 the Product Identification Number (PIN) has changed from 8 to 17 characters. To provide uniform equipment identification, construction equipment manufacturers are moving to comply with the latest version of the product identification numbering standard. Non-road machine PINs are defined by ISO 10261. The new PIN format will apply to all machines and generator sets. The PIN plates and frame marking will display the 17 character PIN. The new format will look like the following:

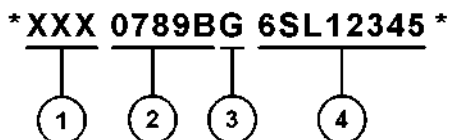

Illustration 1

g03891925

Where:

1. World Manufacturing Code (characters 1-3)

2. Machine Descriptor (characters 4-8)

3. Check Character (character 9)

4. Machine Indicator Section (MIS) or Product Sequence Number (characters 10-17). These were previously referred to as the Serial Number.

Machines and generator sets produced before First Quarter 2001 will maintain their 8 character PIN format.

Components such as engines, transmissions, axles, and work tools will continue to use an 8 character Serial Number (S/N).

Safety Section

i05615090

Safety Messages

SMCS Code: 7000; 7405

There are several specific safety messages on this machine. The exact location of the hazards and the description of the hazards are reviewed in this section. Become familiar with all safety messages.

Make sure that all of the safety messages are legible. Clean the safety messages or replace the safety messages if you cannot read the words. Replace the illustrations if the illustrations are not legible. When you clean the safety messages, use a cloth, water, and soap. Do not use solvent, gasoline, or other harsh chemicals to clean the safety messages. Solvents, gasoline, or harsh chemicals could loosen the adhesive that secures the safety message. Loose adhesive will allow the safety message to fall.

Replace any safety message that is damaged, or missing. If a safety message is attached to a part that is replaced, install a new safety message on the replacement part. Any Cat dealer can provide new safety messages.

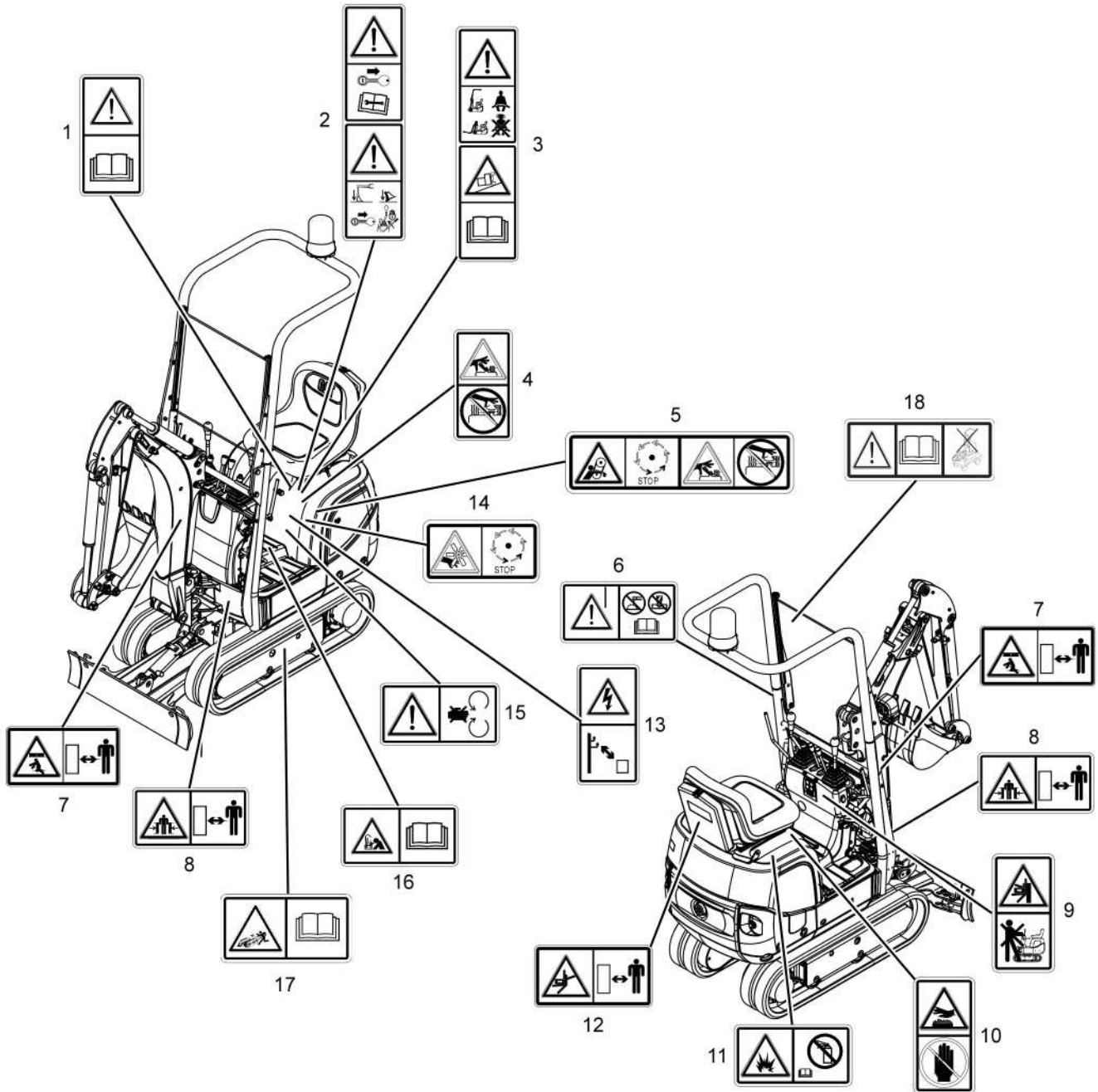

Illustration 2

g03565904

Do Not Operate (1)

This safety message is located on the front of the engine cover. This safety message is also located on the rollover protective structure (ROPS) (if equipped).



Illustration 3

g01030982

⚠ WARNING

DO NOT OPERATE OR WORK ON THIS MACHINE UNLESS YOU HAVE READ AND UNDERSTAND THE INSTRUCTIONS AND WARNINGS IN THE OPERATION AND MAINTENANCE MANUALS. FAILURE TO FOLLOW THE INSTRUCTIONS OR HEED THE WARNINGS COULD RESULT IN INJURY OR DEATH. CONTACT ANY CATERPILLAR DEALER FOR REPLACEMENT MANUALS. PROPER CARE IS YOUR RESPONSIBILITY.

Unexpected Machine Movement (2)

This safety message is located on the front of the engine cover. This safety message is also located on the rollover protective structure (ROPS) (if equipped).

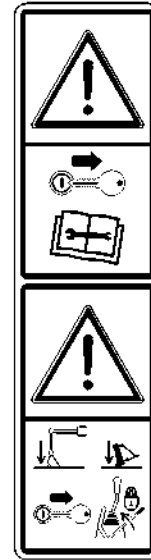

Illustration 4

g02470476

⚠ WARNING

The machine can move unexpectedly and without warning resulting in personal injury or death. Before performing maintenance or repair work on the machine, shut off the engine, move the hydraulic lockout control to the RAISED position, and remove the key. Read the Operation and Maintenance Manual.

Before leaving the machine, lower the boom and dozer blade to the ground, shut off the engine, move the hydraulic lockout control to the RAISED position, and remove the key.

Machine Operation (3)

This safety message is located on the front of the engine cover. This safety message is also located on the rollover protective structure (ROPS) (if equipped).



Illustration 5

g02470582

WARNING

Improper machine operation could cause severe injury or death. Operate the machine only when seated on the seat. Putting the machine into operation and operating the machine with the rollbar (ROPS) raised, is only allowed if the seat belt is fastened and tightened to prevent the operator from falling out of the machine.

Do not fasten the seat belt if the rollbar (ROPS) is lowered.

When operating on a slope, do not exceed the maximum angle. Overloading the machine could impact the machine's stability. Only use work tools that have been approved by Cat. Always work on firm ground.

Refer to Operation and Maintenance Manual, "Slope Operation" and Operation and Maintenance Manual, "Operator Controls" for additional information.

Relieve Hydraulic Tank Pressure (4)

This safety message is located on the hydraulic tank.



Illustration 6

g02470757

WARNING

Pressurized system! The hydraulic tank contains hot oil under pressure. Hot hydraulic oil can cause serious burns. Wear suitable protective clothing and goggles. To prevent burns from the sudden release of hot oil, shut off the engine, wait until the tank is cool. Slowly loosen the fill plug in order to relieve the tank pressure.

Pressurized System and Crushing Hazard (5)

This safety message is located in the engine compartment.

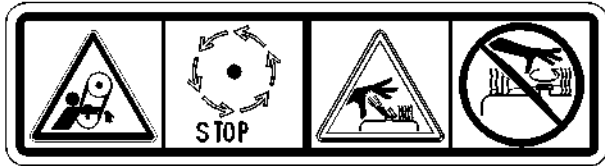

Illustration 7

g02470796

⚠ WARNING

Pressurized system and Rotating parts hazard! Hot coolant can cause serious burns. Wear suitable protective clothing and goggles. To prevent burns from the sudden release of hot coolant, shut off the engine, wait until the cooling system components are cool. Slowly loosen the cooling system pressure cap in order to relieve the tank pressure.

Stay clear of Rotating parts. Entanglement could result in serious injury. Allow rotating parts to come to a complete stop before performing any maintenance or adjustments.

Do Not Weld or Drill on ROPS (6)

This safety message is located on the rollover protective structure (ROPS) (if equipped).

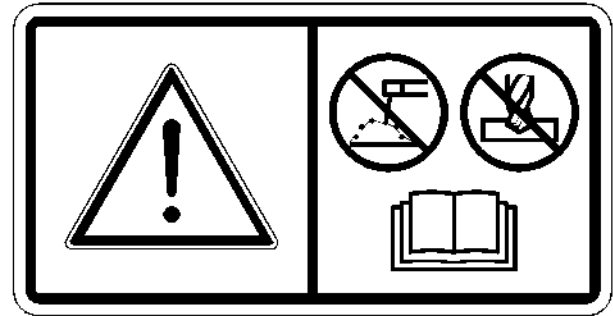

Illustration 8

g02470856

⚠ WARNING

Structural damage, an overturn, modification, alteration, or improper repair can impair this structure's protection capability thereby voiding this certification. Do not weld on or drill holes in the structure. Consult a Caterpillar dealer to determine this structure's limitations without voiding its certification.

Crushing Hazard (7)

This safety message is located on both sides of the boom.

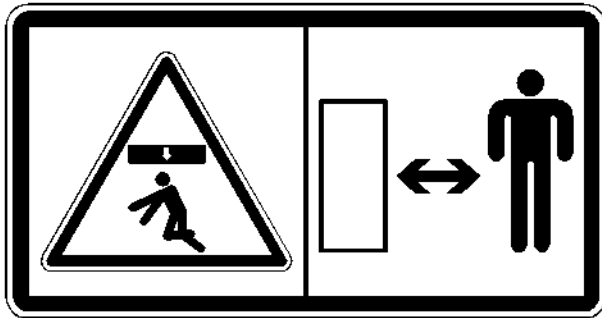

Illustration 9

g02470918

⚠ WARNING

A crushing hazard exists when the stick and boom are in motion and when the machine is being used in object handling applications. Failure to stay clear of the stick and boom when the machine is in operation can result in personal injury or death. Stay clear of the stick and boom when the machine is in operation.

Crushing Hazard (8)

This safety message is located on the left side and right side of the front of the machine.

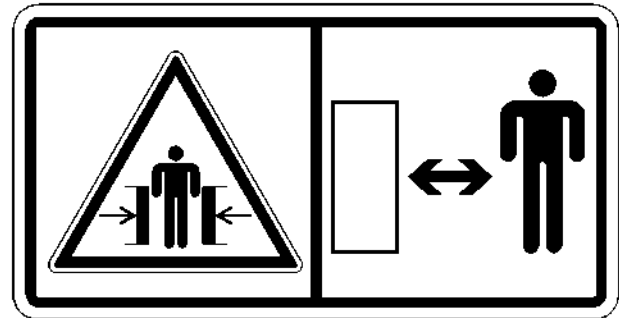

Illustration 10

g02471097

⚠ WARNING

Crushing Hazard! Stay back a safe distance. There is no clearance for a person in this area when the machine turns. Failure to follow these instructions could cause serious injury or death.

Unexpected Machine Movement (9)

This safety message is located on the right side of the operator station.



Illustration 11

g02471158

⚠ WARNING

A machine may move unexpectedly and without warning resulting in personal injury or death. Operate the machine only when seated on the seat. Before leaving the machine, move the hydraulic lockout control to the RAISED position.

Hot Surface (10)

This safety message is located in the engine compartment.



Illustration 12

g02471177

⚠ WARNING

Hot parts or hot components can cause burns or personal injury. Do not allow hot parts or components to contact your skin. Use protective clothing or protective equipment to protect your skin.

Aerosol Starting Aid (11)

This safety message is located next to the air intake.



Illustration 13

g01372254

⚠ WARNING

Explosion hazard! Do not use ether! This machine is equipped with an air inlet heater. Using ether can create explosions or fires that can cause personal injury or death. Read and follow the starting procedure in the Operation and Maintenance Manual.

Crushing Hazard (12)

This safety message is located on the rear of each side of the machine.

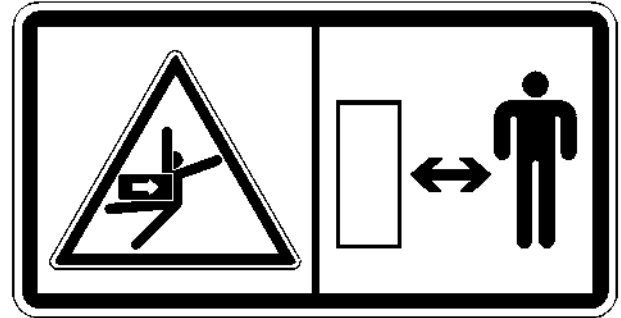

Illustration 14

g02471216

⚠ WARNING

Machine swings. Stay back. Crushing hazard could cause serious injury or death.

Electrical Power Lines (13)

This safety message is located on the left side of the operator station.

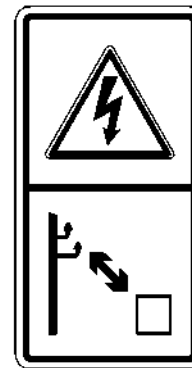

Illustration 15

g02471299

⚠ DANGER

Electrocution Hazard! Keep the machine and attachment a safe distance from electric power. The owner of the electric line should advise a minimum clearance distance. The minimum clearance is 6 m (20 ft) for 220V to 33 kV (Europe) and 5 m (17 ft) for 50kV (USA). Read and understand the instructions and warnings in the Operation and Maintenance Manual. Failure to follow the instructions and warnings will cause serious injury or death.

Refer to Operation and Maintenance Manual, "Specifications" for additional information.

Rotating Parts Hazard (14)

This safety message is located on the front of the engine cover.

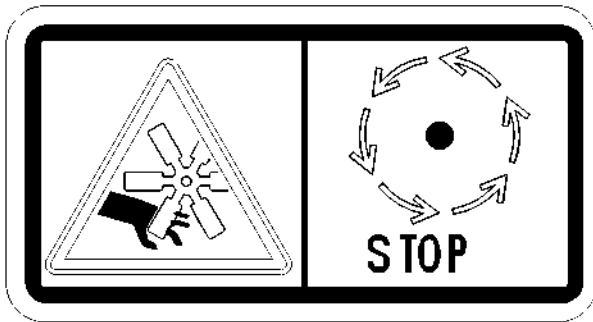

Illustration 16

g02471480

⚠ WARNING
Rotating Parts Hazard! Rotating parts can cause serious injury. Stop the engine before opening the engine cover. Stay clear of the engine compartment if the fan is still running.

Crushing Hazard (15)

This safety message is located on the front of the engine cover.

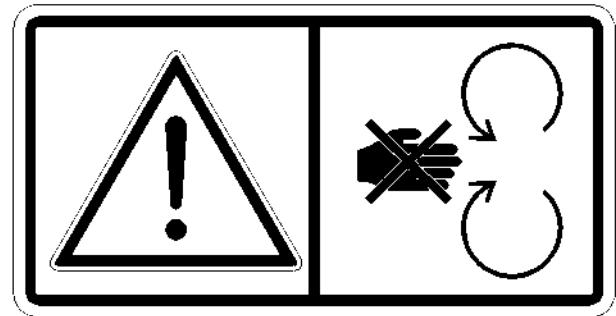

Illustration 17

g02471496

⚠ WARNING
Crushing hazard! Could cause personal injury or death. Shut off the engine and wait until all rotating parts come to a stop before you remove any safety devices such as fan/belt guards.

High Pressure Cylinder (16)

This safety message is located on the undercarriage.

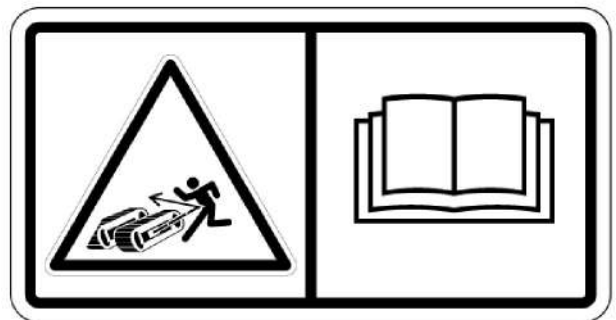

Illustration 18

g02471560

⚠ WARNING
High Pressure Cylinder! Do not remove any parts from the cylinder until all of the pressure has been relieved. Grease under pressure can penetrate the body causing personal injury or death.
Read and understand the Operation and Maintenance Manual before performing adjustments to the track tensioner.

Refer to Operation and Maintenance Manual, "Track Adjustment - Adjust" for further information.

Jump Start Cables (17)

This safety message is located at the operator station.

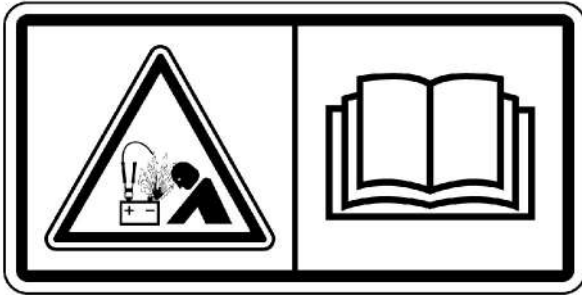

Illustration 19

g01370909

WARNING

Explosion Hazard! Improper jumper cable connections can cause an explosion resulting in serious injury or death. Batteries may be located in separate compartments. Refer to the Operation and Maintenance Manual for the correct jump starting procedure.

Refer to Operation and Maintenance Manual, "Engine Starting with Jump Start Cables" for further information.

Remove Before Transport (18)

This safety message is located on the polycarbonate shield.

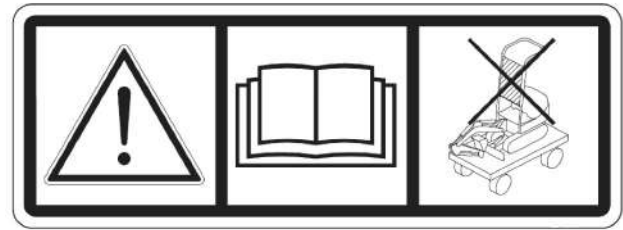

Illustration 20

g03565974

WARNING

Failure to remove the polycarbonate shield can cause personal injury or property damage. The polycarbonate shield may become deformed, or detached from the machine due to increased air pressure. Remove the polycarbonate shield if the machine is transported on an open platform.

Refer to Operation and Maintenance Manual, "Window (Front)" for further information.

i04243335

General Hazard Information

SMCS Code: 7000

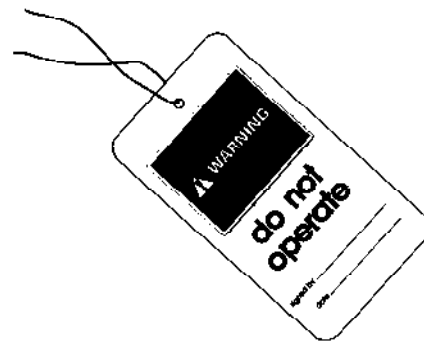

Illustration 21

g00104545

Attach a "Do Not Operate" warning tag or a similar warning tag to the start switch or to the controls. Attach the warning tag before you service the equipment or before you repair the equipment. These warning tags (Special Instruction, SEHS7332) are available from your Cat dealer.

⚠ WARNING

Operating the machine while distracted can result in the loss of machine control. Use extreme caution when using any device while operating the machine. Operating the machine while distracted can result in personal injury or death.

Know the width of your equipment in order to maintain proper clearance when you operate the equipment near fences or near boundary obstacles.

Be aware of high voltage power lines and power cables that are buried. If the machine comes in contact with these hazards, serious injury or death may occur from electrocution.

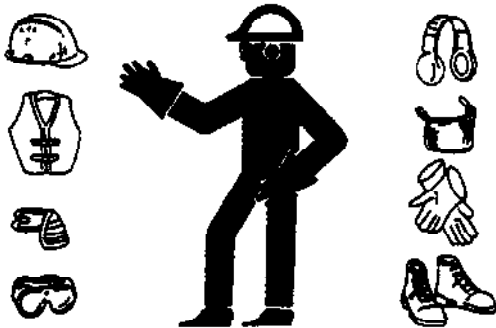

Illustration 22

g00702020

Wear a hard hat, protective glasses, and other protective equipment, as required.

Do not wear loose clothing or jewelry that can snag on controls or on other parts of the equipment.

Make sure that all protective guards and all covers are secured in place on the equipment.

Keep the equipment free from foreign material. Remove debris, oil, tools, and other items from the deck.

Remove all loose items such as lunch boxes, tools, and other items that are not a part of the equipment.

Know the appropriate work site hand signals and the personnel that are authorized to give the hand signals. Accept hand signals from one person only.

Never put maintenance fluids into glass containers. Drain all liquids into a suitable container.

Obey all local regulations for the disposal of liquids.

Use all cleaning solutions with care. Report all necessary repairs.

Do not allow unauthorized personnel on the equipment.

Unless you are instructed otherwise, perform maintenance with the equipment in the servicing position. Refer to Operation and Maintenance Manual for the procedure for placing the equipment in the servicing position.

When you perform maintenance above ground level, use appropriate devices such as ladders or man lift machines. If equipped, use the machine anchorage points and use approved fall arrest harnesses and lanyards.

Pressurized Air and Water

Pressurized air and/or water can cause debris and/or hot water to be blown out. The debris and/or hot water could result in personal injury.

When pressurized air and/or pressurized water is used for cleaning, wear protective clothing, protective shoes, and eye protection. Eye protection includes goggles or a protective face shield.

The maximum air pressure for cleaning purposes must be reduced to 205 kPa (30 psi) when the nozzle is deadheaded and the nozzle is used with an effective chip deflector and personal protective equipment. The maximum water pressure for cleaning purposes must be below 275 kPa (40 psi).

Trapped Pressure

Pressure can be trapped in a hydraulic system. Releasing trapped pressure can cause sudden machine movement or attachment movement. Use caution if you disconnect hydraulic lines or fittings. High-pressure oil that is released can cause a hose to whip. High-pressure oil that is released can cause oil to spray. Fluid penetration can cause serious injury and possible death.

Fluid Penetration

Pressure can be trapped in the hydraulic circuit long after the engine has been stopped. The pressure can cause hydraulic fluid or items such as pipe plugs to escape rapidly if the pressure is not relieved correctly.

Do not remove any hydraulic components or parts until pressure has been relieved or personal injury may occur. Do not disassemble any hydraulic components or parts until pressure has been relieved or personal injury may occur. Refer to the Service Manual for any procedures that are required to relieve the hydraulic pressure.

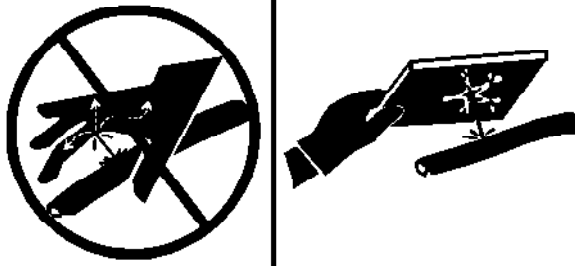

Illustration 23

g00687600

Always use a board or cardboard when you check for a leak. Leaking fluid that is under pressure can penetrate body tissue. Fluid penetration can cause serious injury and possible death. A pin hole leak can cause severe injury. If fluid is injected into your skin, you must get treatment immediately. Seek treatment from a doctor that is familiar with this type of injury.

Containing Fluid Spillage

Care must be taken in order to ensure that fluids are contained during performance of inspection, maintenance, testing, adjusting, and repair of the equipment. Prepare to collect the fluid with suitable containers before opening any compartment or disassembling any component that contains fluids.

Refer to Special Publication, NENG2500, "Caterpillar Dealer Service Tool Catalog" for the following items:

- Tools that are suitable for collecting fluids and equipment that is suitable for collecting fluids
- Tools that are suitable for containing fluids and equipment that is suitable for containing fluids

Obey all local regulations for the disposal of liquids.

Inhalation

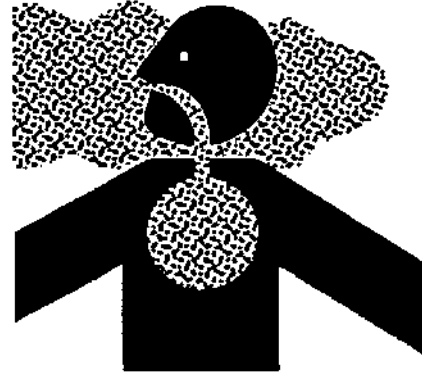

Illustration 24

g02159053

Exhaust

Use caution. Exhaust fumes can be hazardous to your health. If you operate the machine in an enclosed area, adequate ventilation is necessary.

Asbestos Information

Cat equipment and replacement parts that are shipped from Caterpillar are asbestos free. Caterpillar recommends the use of only genuine Cat replacement parts. Use the following guidelines when you handle any replacement parts that contain asbestos or when you handle asbestos debris.

Use caution. Avoid inhaling dust that might be generated when you handle components that contain asbestos fibers. Inhaling this dust can be hazardous to your health. The components that may contain asbestos fibers are brake pads, brake bands, lining material, clutch plates, and some gaskets. The asbestos that is used in these components is bound in a resin or sealed in some way. Normal handling is not hazardous unless airborne dust that contains asbestos is generated.

If dust that may contain asbestos is present, there are several guidelines that should be followed:

- Never use compressed air for cleaning.
- Avoid brushing materials that contain asbestos.
- Avoid grinding materials that contain asbestos.
- Use a wet method in order to clean up asbestos materials.
- A vacuum cleaner that is equipped with a high efficiency particulate air filter (HEPA) can also be used.

- Use exhaust ventilation on permanent machining jobs.
- Wear an approved respirator if there is no other way to control the dust.
- Comply with applicable rules and regulations for the work place. In the United States, use Occupational Safety and Health Administration (OSHA) requirements. These OSHA requirements can be found in “29 CFR 1910.1001”.
- Obey environmental regulations for the disposal of asbestos.
- Stay away from areas that might have asbestos particles in the air.

Dispose of Waste Properly

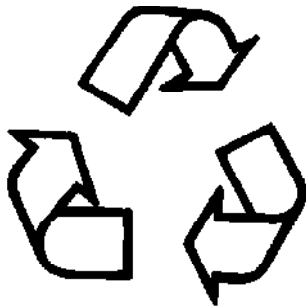

Illustration 25

g00706404

i07746334

Improperly disposing of waste can threaten the environment. Potentially harmful fluids should be disposed of according to local regulations.

Always use leakproof containers when you drain fluids. Do not pour waste onto the ground, down a drain, or into any source of water.

i05374155

Crushing Prevention and Cutting Prevention

SMCS Code: 7000

Support the equipment properly before you perform any work or maintenance beneath that equipment. Do not depend on the hydraulic cylinders to hold up the equipment. Equipment can fall if a control is moved, or if a hydraulic line were to break.

Do not work beneath the canopy of the machine unless the canopy is properly supported.

Unless you are instructed otherwise, never attempt adjustments while the machine is moving or while the engine is running.

Never jump across the starter solenoid terminals in order to start the engine. Unexpected machine movement could result.

Whenever there are equipment control linkages the clearance in the linkage area will change with the movement of the equipment or the machine. Stay clear of areas that may have a sudden change in clearance with machine movement or equipment movement.

Stay clear of all rotating and moving parts.

If necessary to remove guards in order to perform maintenance, always install the guards after the maintenance is performed.

Keep objects away from moving fan blades. The fan blade will throw objects or cut objects.

Do not use a kinked wire cable or a frayed wire cable. Wear gloves when you handle wire cable.

When you strike a retainer pin with force, the retainer pin can fly out. The loose retainer pin can injure personnel. Make sure that the area is clear of people when you strike a retainer pin. To avoid injury to your eyes, wear protective glasses when you strike a retainer pin.

Chips or other debris can fly off an object when you strike the object. Make sure that no one can be injured by flying debris before striking any object.

Burn Prevention

SMCS Code: 7000

Do not touch any part of an operating engine. Allow the engine to cool before any maintenance is performed on the engine. Relieve all pressure in the air system, in the oil system, in the lubrication system, in the fuel system, or in the cooling system before any lines, fittings, or related items are disconnected.

Coolant

When the engine is at operating temperature, the engine coolant is hot. The coolant is also under pressure. The radiator and all lines to the heaters or to the engine contain hot coolant.

Any contact with hot coolant or with steam can cause severe burns. Allow cooling system components to cool before the cooling system is drained.

Check the coolant level only after the engine has been stopped.

Safety Section

Fire Prevention and Explosion Prevention

Ensure that the filler cap is cool before removing the filler cap. The filler cap must be cool enough to touch with a bare hand. Remove the filler cap slowly to relieve pressure.

Cooling system conditioner contains alkali. Alkali can cause personal injury. Do not allow alkali to contact the skin, the eyes, or the mouth.

Oils

Hot oil and hot components can cause personal injury. Do not allow hot oil to contact the skin. Also, do not allow hot components to contact the skin.

Remove the hydraulic tank filler cap only after the engine has been stopped. The filler cap must be cool enough to touch with a bare hand. Follow the standard procedure in this manual to remove the hydraulic tank filler cap.

Batteries

The liquid in a battery is an electrolyte. Electrolyte is an acid that can cause personal injury. Do not allow electrolyte to contact the skin or the eyes.

Do not smoke while checking the battery electrolyte levels. Batteries give off flammable fumes which can explode.

Always wear protective glasses when you work with batteries. Wash hands after touching batteries. The use of gloves is recommended.

i05374600

Fire Prevention and Explosion Prevention

SMCS Code: 7000



Illustration 26

g00704000

General

All fuels, most lubricants, and some coolant mixtures are flammable.

To minimize the risk of fire or explosion, Caterpillar recommends the following actions.

Always perform a Walk-Around Inspection, which may help you identify a fire hazard. Do not operate a machine when a fire hazard exists. Contact your Cat dealer for service.

Understand the use of the primary exit and alternative exit on the machine. Refer to Operation and Maintenance Manual, "Alternative Exit".

Do not operate a machine with a fluid leak. Repair leaks and clean up fluids before resuming machine operation. Fluids that are leaking or spilled onto hot surfaces or onto electrical components can cause a fire. A fire may cause personal injury or death.

Remove flammable material such as leaves, twigs, papers, trash, and so on. These items may accumulate in the engine compartment or around other hot areas and hot parts on the machine.

Keep the access doors to major machine compartments closed and access doors in working condition in order to permit the use of fire suppression equipment, in case a fire should occur.

Clean all accumulations of flammable materials such as fuel, oil, and debris from the machine.

Do not operate the machine near any flame.

Keep shields in place. Exhaust shields (if equipped) protect hot exhaust components from oil spray or fuel spray in case of a break in a line, in a hose, or in a seal. Exhaust shields must be installed correctly.

Do not weld or flame cut on tanks or lines that contain flammable fluids or flammable material. Empty and purge the lines and tanks. Then clean the lines and tanks with a nonflammable solvent prior to welding or flame cutting. Ensure that the components are properly grounded in order to avoid unwanted arcs.

Dust that is generated from repairing nonmetallic hoods or fenders may be flammable and/or explosive. Repair such components in a ventilated area away from open flames or sparks. Use suitable Personal Protection Equipment (PPE).

Inspect all lines and hoses for wear or deterioration. Replace damaged lines and hoses. The lines and the hoses should have adequate support and secure clamps. Tighten all connections to the recommended torque. Damage to the protective cover or insulation may provide fuel for fires.

Store fuels and lubricants in properly marked containers away from unauthorized personnel. Store oily rags and flammable materials in protective containers. Do not smoke in areas that are used for storing flammable materials.



Illustration 27

g00704059

Use caution when you are fueling a machine. Do not smoke while you are fueling a machine. Do not fuel a machine near open flames or sparks. Always stop the engine before fueling. Fill the fuel tank outdoors. Properly clean areas of spillage.

Avoid static electricity risk when fueling. Ultra low sulfur diesel (ULSD) poses a greater static ignition hazard than earlier diesel formulations with a higher sulfur content. Avoid death or serious injury from fire or explosion. Consult with your fuel or fuel system supplier to ensure that the delivery system is in compliance with fueling standards for proper grounding and bonding practices.

Never store flammable fluids in the operator compartment of the machine.

Battery and Battery Cables



Illustration 28

g02298225

Caterpillar recommends the following in order to minimize the risk of fire or an explosion related to the battery.

Do not operate a machine if battery cables or related parts show signs of wear or damage. Contact your Cat dealer for service.

Follow safe procedures for engine starting with jump-start cables. Improper jumper cable connections can cause an explosion that may result in injury. Refer to Operation and Maintenance Manual, "Engine Starting with Jump Start Cables" for specific instructions.

Do not charge a frozen battery. This may cause an explosion.

Gases from a battery can explode. Keep any open flames or sparks away from the top of a battery. Do not smoke in battery charging areas.

Never check the battery charge by placing a metal object across the terminal posts. Use a voltmeter in order to check the battery charge.

Safety Section

Fire Prevention and Explosion Prevention

Daily inspect battery cables that are in areas that are visible. Inspect cables, clips, straps, and other restraints for damage. Replace any damaged parts. Check for signs of the following, which can occur over time due to use and environmental factors:

- Fraying
- Abrasion
- Cracking
- Discoloration
- Cuts on the insulation of the cable
- Fouling
- Corroded terminals, damaged terminals, and loose terminals

Replace damaged battery cable(s) and replace any related parts. Eliminate any fouling, which may have caused insulation failure or related component damage or wear. Ensure that all components are reinstalled correctly.

An exposed wire on the battery cable may cause a short to ground if the exposed area comes into contact with a grounded surface. A battery cable short produces heat from the battery current, which may be a fire hazard. Repair components or replace components before servicing the machine.

WARNING

Fire on a machine can result in personal injury or death. Exposed battery cables that come into contact with a grounded connection can result in fires. Replace cables and related parts that show signs of wear or damage. Contact your Cat dealer.

Wiring

Check electrical wires daily. If any of the following conditions exist, replace parts before you operate the machine.

- Fraying
- Signs of abrasion or wear
- Cracking
- Discoloration
- Cuts on insulation
- Other damage

Make sure that all clamps, guards, clips, and straps are reinstalled correctly. This will help to prevent vibration, rubbing against other parts, and excessive heat during machine operation.

Attaching electrical wiring to hoses and tubes that contain flammable fluids or combustible fluids should be avoided.

Consult your Cat dealer for repair or for replacement parts.

Keep wiring and electrical connections free of debris.

Lines, Tubes, and Hoses

Do not bend high-pressure lines. Do not strike high-pressure lines. Do not install any lines that are bent or damaged. Use the appropriate backup wrenches in order to tighten all connections to the recommended torque.

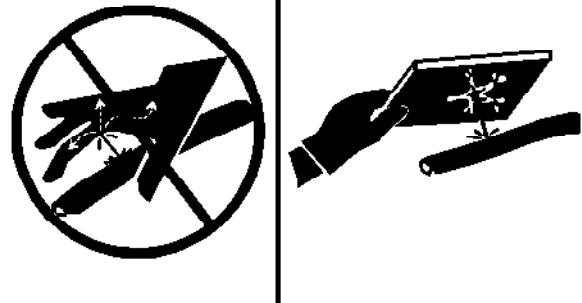

Illustration 29

g00687600

Check lines, tubes, and hoses carefully. Wear Personal Protection Equipment (PPE) in order to check for leaks. Always use a board or cardboard when you check for a leak. Leaking fluid that is under pressure can penetrate body tissue. Fluid penetration can cause serious injury and possible death. A pin hole leak can cause severe injury. If fluid is injected into your skin, you must get treatment immediately. Seek treatment from a doctor that is familiar with this type of injury.

Replace the affected parts if any of the following conditions are present:

- End fittings are damaged or leaking.
- Outer coverings are chafed or cut.
- Wires are exposed.
- Outer coverings are swelling or ballooning.
- Flexible parts of the hoses are kinked.
- Outer covers have exposed embedded armoring.
- End fittings are displaced.

Make sure that all clamps, guards, and heat shields are installed correctly. During machine operation, this will help to prevent vibration, rubbing against other parts, excessive heat, and failure of lines, tubes, and hoses.

Do not operate a machine when a fire hazard exists. Repair any lines that are corroded, loose, or damaged. Leaks may provide fuel for fires. Consult your Cat dealer for repair or for replacement parts. Use genuine Cat parts or the equivalent, for capabilities of both the pressure limit and temperature limit.

Ether

Ether is flammable and poisonous. Do not spray ether into an engine if the machine is equipped with a thermal starting aid for cold weather starting. Follow the correct cold engine starting procedures. Refer to the section in the Operation and Maintenance Manual, "Engine Starting".

Fire Extinguisher

As an additional safety measure, keep a fire extinguisher on the machine.

Be familiar with the operation of the fire extinguisher. Inspect the fire extinguisher and service the fire extinguisher regularly. Follow the recommendations on the instruction plate.

Consider installation of an aftermarket Fire Suppression System, if the application and working conditions warrant the installation.

i04254329

Fire Extinguisher Location

SMCS Code: 7000; 7419

Make sure that a fire extinguisher is available. Be familiar with the operation of the fire extinguisher and service the fire extinguisher regularly. Obey the recommendations on the instruction plate.



Illustration 30

g02425257

A fire extinguisher can be installed beneath the back of the operator seat.

Consult your Cat dealer for the installation of a fire extinguisher.

i01329108

Track Information

SMCS Code: 4170; 7000

Track adjusting systems use either grease or oil under high pressure to keep the track under tension.

Grease or oil under high pressure coming out of the relief valve can penetrate the body causing injury or death. Do not watch the relief valve to see if grease or oil is escaping. Watch the track or track adjustment cylinder to see if the track is being loosened.

The pins and bushings in a dry track pin joint can become very hot. It is possible to burn the fingers if there is more than brief contact with these components.

i04243389

Electrical Storm Injury Prevention

SMCS Code: 7000

When lightning is striking in the vicinity of the machine, stop the work that is being performed. Leave the area, and stay away from the vicinity of the machine.

i04254433

Before Starting Engine

SMCS Code: 1000; 7000

Start the engine only from the operator seat. Do not short across the battery terminals. Bypassing the engine neutral start system can damage the electrical system.

Inspect the condition of the seat belt and the condition of the mounting hardware. Replace any damaged parts or worn parts. Regardless of appearance, replace the seat belt after 3 years of use. Do not use an extension for a seat belt on a retractable seat belt.

Adjust the seat so that full pedal travel can be achieved. Adjust the seat so that full lever travel can be achieved. Make sure that your back is against the back of the seat.

Make sure that the machine is equipped with a lighting system that is adequate for the job conditions. Make sure that all lights are working properly.

Make sure that the hydraulic lockout control is in the RAISED position. When the hydraulic lockout control is in the RAISED position, the controls and drive levers will be deactivated.

WARNING

Deactivation of the controls and drive levers does not prevent the blade, boom swing, or auxiliary circuit functions from moving, if the blade lever or a foot pedal is moved.

Personal injury or death may occur from sudden machine movement.

Before you start the engine and before you move the machine, make sure that no personnel are underneath the machine, around the machine, or on the machine. Make sure that the area is free of personnel.

i04450732

Visibility Information

SMCS Code: 7000

Before you start the machine, perform a walk-around inspection in order to ensure that there are no hazards around the machine.

While the machine is in operation, constantly survey the area around the machine in order to identify potential hazards as hazards become visible around the machine.

Your machine may be equipped with visual aids. Examples of visual aids are mirrors. Before operating the machine, ensure that the visual aids are in proper working condition and that the visual aids are clean. Adjust the visual aids using the procedures that are located in this Operation and Maintenance Manual.

It may not be possible to provide direct visibility on large machines to all areas around the machine. Appropriate job site organization is required in order to minimize hazards that are caused by restricted visibility. Job site organization is a collection of rules and procedures that coordinates machines and people that work together in the same area. Examples of job site organization include the following:

- Safety instructions
- Controlled patterns of machine movement and vehicle movement
- Workers that direct traffic to move when safe
- Restricted areas
- Operator training
- Warning symbols or warning signs on machines or on vehicles
- A system of communication
- Communication between workers and operators prior to approaching the machine

Modifications of the machine configuration by the user that result in a restriction of visibility shall be evaluated.

Restricted Area

The restricted area is the area in which persons are in danger due to the movements of the:

- machine
- work equipment
- additional equipment or
- material

This also includes the area affected by falling material, equipment, or by parts which are thrown out.

The danger area must be extended by 0.5 m (20 inch) in the immediate vicinity of:

- buildings
- scaffolds or
- other elements of construction

Seal off the restricted area if not possible to keep a safe distance. Stop work if persons do not leave the restricted area in spite of warning. Keep out of the danger area.

i04258930

Engine Starting

SMCS Code: 1000; 7000

If a warning tag is attached to the start switch or to the controls, do not start the engine. Also, do not move any controls.

Before you start the engine, make sure that all hydraulic control levers and pedals are at the neutral position.

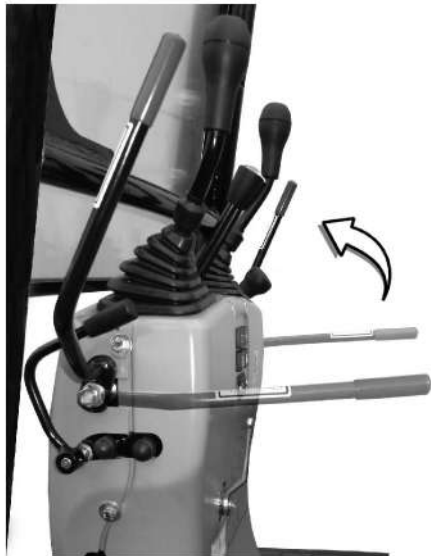

Illustration 31

g02429279

Put the hydraulic lockout control in the RAISED position.

Diesel engine exhaust contains products of combustion which can be harmful to your health. Always start the engine in a ventilated area. Always operate the engine in a ventilated area. If you are in an enclosed area, vent the exhaust to the outside.

i04258931

Before Operation

SMCS Code: 7000

Clear all personnel from the machine and from the area.

Clear all obstacles from the path of the machine. Beware of hazards for example such as wires, ditches.

If equipped, make sure that the polycarbonate shield is clean.

For the best vision of the area that is close to the machine, adjust the rear view mirrors (if equipped).

Make sure that the machine horn, the travel alarm (if equipped) and all other warning devices are working properly.

Fasten the seat belt securely.

i04258932

Work Tools

SMCS Code: 6700

Only use work tools that are recommended by Caterpillar for use on Cat machines.

Use of work tools, including buckets, which are outside of Caterpillar's recommendations or specifications for weight, dimensions, flows, pressures, and so on, may result in less-than-optimal vehicle performance, including but not limited to reductions in production, stability, reliability, and component durability. Caterpillar recommends appropriate work tools for our machines to maximize the value our customers receive from our products. Caterpillar understands that special circumstances may lead a customer to use tools outside of our specifications. In these cases, customers must be aware that such choices can reduce vehicle performance and will affect their ability to claim warranty in the event of what a customer may perceive as a premature failure.

Work tools and work tool control systems, that are compatible with your Cat machine, are required for safe machine operation and/or reliable machine operation. If you are in doubt about the compatibility of a particular work tool with your machine, consult your Cat dealer.

Make sure that all necessary guarding is in place on the host machine and on the work tool.

A polycarbonate shield must be used when a work tool could throw debris.

Do not exceed the maximum operating weight that is listed on the ROPS certification.

Always wear protective glasses. Always wear the protective equipment that is recommended in the operation manual for the work tool. Wear any other protective equipment that is required for the operating environment.

To prevent personnel from being struck by flying objects, ensure that all personnel are out of the work area.

While you are performing any maintenance, any testing, or any adjustments to the work tool stay clear of the following areas: cutting edges, pinching surfaces and crushing surfaces.

Never use the work tool for a work platform.

i07889511

Operation

SMCS Code: 7000

Machine Operating Temperature Range

The machine must function satisfactorily in the anticipated ambient temperature limits that are encountered during operation. The standard machine configuration is intended for use within an ambient temperature range of $-18\text{ }^{\circ}\text{C}$ ($0\text{ }^{\circ}\text{F}$) to $43\text{ }^{\circ}\text{C}$ ($109\text{ }^{\circ}\text{F}$). Special configurations for different ambient temperatures may be available. Consult your Cat dealer for additional information on special configurations of your machine.

Limiting Conditions and Criteria

Limiting conditions are immediate issues with this machine that must be addressed prior to continuing operation.

The Operation and Maintenance Manual, Safety Section describes limiting condition criteria for replacing items such as safety messages, seat belt and mounting hardware, lines, tubes, hoses, battery cables and related parts, electrical wires, and repairing any fluid leak.

The Operation and Maintenance Manual, Maintenance Interval Schedule describes limiting condition criteria that require repair or replacement for items (if equipped) such as alarms, horns, braking system, steering system, and rollover protective structures.

Table 1

System or Component Name	Limiting Condition	Criteria for Action	Required Action
Line, tubes, and hoses	End fittings are damaged or leaking. Outer coverings are chafed or cut. Wires are exposed. Outer coverings are swelling or ballooning. Flexible parts of the hoses are kinked. Outer covers have exposed embedded armoring. End fittings are displaced.	Visible corrosion, loose, or damaged lines, tubes, or hoses. Visible fluid leaks.	Immediately repair any lines, tubes, or hoses that are corroded, loose, or damaged. Immediately repair any leaks as these may provide fuel for fires.
Electrical Wiring	Signs of fraying, abrasion, cracking, discoloration, cuts on the insulation	Visible damage to electrical wiring	Immediately replace damaged wiring

The Operation and Maintenance Manual, Monitoring System (if equipped) provides information on limiting condition criteria, including a Warning Category 3 that requires immediate shutdown of the engine.

Critical Failures

The following table provides summary information on several limiting conditions found in this Operation and Maintenance Manual. The table provides criteria and required action for the limiting conditions listed. Each System or Component in this table, together with the respective limiting condition, describes a potential critical failure that must be addressed. Not addressing limiting conditions with required actions may, in conjunction with other factors or circumstances, result in a risk of personal injury or death. If an accident occurs, notify emergency personnel and provide location and description of accident.

(continued)

(Table 1, contd)

System or Component Name	Limiting Condition	Criteria for Action	Required Action
Battery cable(s)	Signs of fraying, abrasion, cracking, discoloration, cuts on the insulation of the cable, fouling, corroded terminals, damaged terminals, and loose terminals	Visible damage to battery cable(s)	Immediately replace damaged battery cables
Operator Protective Structure	Structures that are bent, cracked, or loose. Loose, missing, or damaged bolts.	Visible damage to structure. Loose, missing, or damaged bolts.	Do not operate machine with damaged structure or loose, missing, or damaged bolts. Contact your Cat dealer for inspection and repair or replacement options.
Seat Belt	Worn or damaged seat belt or mounting hardware	Visible wear or damage	Immediately replace parts that are worn or damaged.
Seat Belt	Age of seat belt	Three years after date of installation	Replace seat belt three years after date of installation
Safety Messages	Appearance of safety message	Damage to safety messages making them illegible	Replace the illustrations if illegible.
Audible Warning Device(s) (if equipped)	Sound level of audible warning	Reduced or no audible warning present	Immediately repair or replace audible warning devices not working properly.
Camera(s) (if equipped)	Dirt or debris on camera lens	Dirt or debris obstructing camera view	Clean camera before operating machine.
Cab Windows (if equipped)	Dirt, debris, or damaged windows	Dirt or debris obstructing operator visibility. Any damaged windows.	Clean windows before operating machine. Repair or replace damaged windows before operating machine.
Mirrors (if equipped)	Dirt, debris, or damaged mirror	Dirt or debris obstructing operator visibility. Any damaged mirrors.	Clean mirrors before operating machine. Repair or replace damaged mirrors before operating machine.
Braking System	Inadequate braking performance	System does not pass Braking System - Test(s) included in Maintenance Section or in the Testing and Adjusting Manual	Contact your Cat dealer to inspect and, if necessary, repair the brake system.
Cooling System	The coolant temperature is too high.	Monitoring System displays Warning Category 3	Stop the engine immediately. Check the coolant level and check the radiator for debris. Refer to Operation and Maintenance Manual, Cooling System Coolant Level - Check. Check the fan drive belts for the water pump. Refer to Operation and Maintenance Manual, Belts - Inspect/Adjust/ Replace. Make any necessary repairs.
Engine Oil System	A problem has been detected with the engine oil pressure.	Monitoring System displays Warning Category 3	If the warning stays on during low idle, stop the engine and check the engine oil level. Perform any necessary repairs as soon as possible.
Engine system	An engine fault has been detected by the engine ECM.	Monitoring System displays Warning Category 3	Stop the engine immediately. Contact your Cat dealer for service.
Fuel System	A problem has been detected with the fuel system.	Monitoring System displays Warning Category 3	Stop the engine. Determine the cause of the fault and perform any necessary repairs.
Hydraulic Oil System	The hydraulic oil temperature is too high.	Monitoring System displays Warning Category 3	Stop the engine immediately. Check the hydraulic oil level and check the hydraulic oil cooler for debris. Perform any necessary repairs as soon as possible.
Steering System	A problem has been detected with the steering system. (If equipped with steering system monitoring.)	Monitoring System displays Warning Category 3	Move machine to a safe location and stop the engine immediately. Contact your Cat dealer to inspect and, if necessary, repair the steering system.
Overall Machine	Machine service is required.	Monitoring System displays Warning Category 3	Stop the engine immediately. Contact your Cat dealer for service.

Machine Operation

Only operate the machine while you are in a seat. The seat belt must be fastened while you operate the machine. Only operate the controls while the engine is running.

Check for proper operation of all controls and of all protective devices while you operate the machine slowly in an open area.

When the machine is moving watch the clearance of the boom. Uneven ground can cause the boom to move in all directions.

Safety Section Operation

Make sure that no personnel will be endangered before you move the machine. Do not allow riders on the machine unless the machine has an additional seat with a seat belt.

Report any machine damage that was noted during machine operation. Make any necessary repairs.

Never use the work tool for a work platform.

Hold attachments approximately 40 cm (15 inches) above ground level while you drive the machine. Do not drive the machine close to an overhang, to the edge of a cliff, or to the edge of an excavation.

If the machine begins to sideslip on a grade, immediately dump the load and turn the machine downhill.

Be careful to avoid any ground condition which could cause the machine to tip. Tipping can occur when you work on hills, on banks, or on slopes. Tipping can also occur when you cross ditches, ridges, or other unexpected obstructions.

When possible, operate the machine up slopes and down slopes with the final drive sprockets facing down the slope. Avoid operating the machine across the slope. Place the heaviest end of the machine uphill when you are working on an incline.

Keep the machine under control. Do not overload the machine beyond capacity.

Avoid changing the direction of travel on a slope. Changing the direction of travel on a slope could result in tipping or side slipping of the machine.

Bring the load close to the machine before traveling any distances.

Bring the load close to the machine before swinging the load.

Lifting capacity decreases as the load is moved further from the machine.

Make sure that the towing eyes and the towing devices are adequate for your needs.

Only connect trailing equipment to a drawbar or to a hitch.

Never straddle a wire cable. Never allow other personnel to straddle a wire cable.

When you maneuver in order to connect the equipment, make sure that no personnel are between the machine and trailing equipment. Block up the hitch of the trailing equipment in order to align the equipment with the drawbar.

Check the local regulations, state codes, and/or directives of the job site for a specific minimum distance from obstacles.

Before you operate the machine, check with local utilities for the locations of underground pipes and for the locations of buried cables.

Know the maximum dimensions of your machine.

Watch the load at all times.

Do not operate the machine without the counterweight. The machine can tip when the boom is over the side.

The clamshell, the grapple, or the magnet can swing in all directions. Move the joysticks in a continuous motion. Failure to move the joysticks in a continuous motion can cause the clamshell, the grapple, or the magnet to swing into the cab or into a person in the work area. This will result in personal injury.

Certain machine front linkage combinations (boom, stick, quick coupler, work tool) can allow the work tool to contact the machine undercarriage, swing frame, boom, boom hydraulic cylinder and or the cab. Be aware of the position of the work tool while you operate the machine.

Shut down the machine until damaged or non-functioning visibility aid(s) is repaired (if applicable) or until appropriate job site organization is used to minimize hazards that are caused by any resulting restricted visibility.

Machine Operation when the Machine is not Completely Assembled

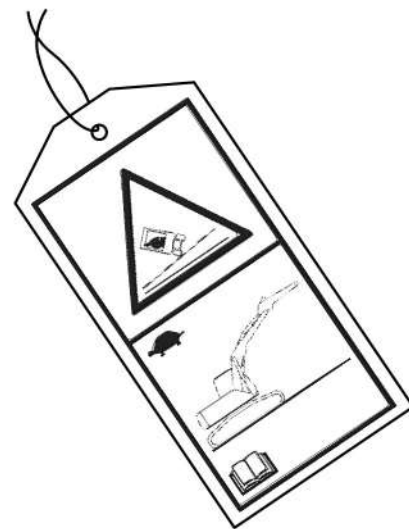

Illustration 32

g02202544

Attach the tag to the controls of the machine. When the tag is attached to the controls, operate the machine as described below.

If the machine needs to be operated without the boom, stick, and/or counterweight being installed, the machine should be operated slowly on flat, stable ground or pavement by qualified operators. Avoid any machine operations which could affect machine stability, including the swing function. The ROPS structural certification depends on the support of the boom, stick, and counterweight in the event of a machine tip over or a machine rollover incident.

i04258934

Engine Stopping

SMCS Code: 1000; 7000

Do not stop the engine immediately after the machine has been operated under load. This action can cause overheating and accelerated wear of engine components.

After the machine is parked, allow the engine to run for 2 minutes before shutdown. Running the engine for 2 minutes before shutdown allows hot areas of the engine to cool gradually.

i04258935

Lifting Objects

SMCS Code: 7000

Lifting objects with this machine is NOT ALLOWED.

i04258936

Parking

SMCS Code: 7000

When the engine is turned off, movement of the hydraulic equipment can occur under the following conditions:

- The work tool is not positioned on the ground.
- The work tool drifts when the equipment is not supported.

WARNING

Deactivation of the controls and drive levers does not prevent the blade, boom swing, or auxiliary circuit functions from moving, if the blade lever or a foot pedal is moved.

Personal injury or death may occur from sudden machine movement.

1. Park on a level surface. If necessary to park on a grade, chock the tracks.

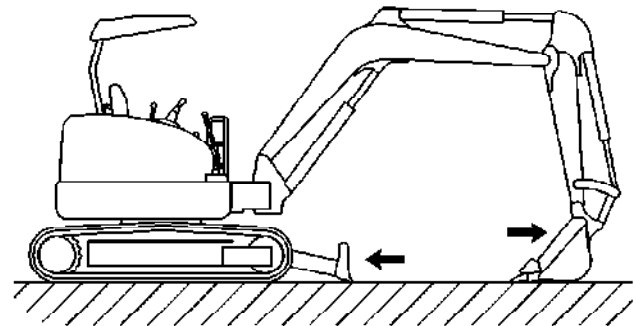

Illustration 33

g00811194

2. Lower the work tools and the blade to the ground.
3. Move the governor control lever to the LOW idle position and operate the engine at low idle for 5 minutes in order to allow the engine to cool down.
4. Turn the engine start switch to the OFF position and remove the key.

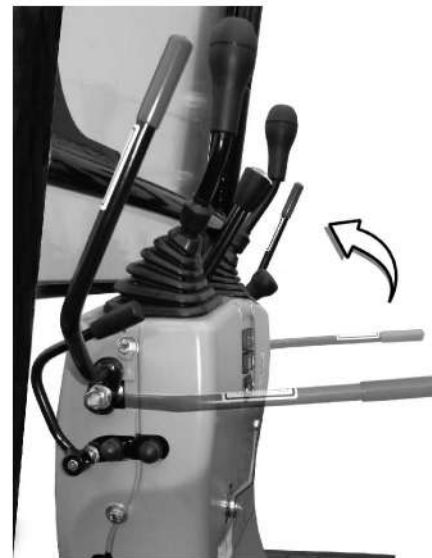

Illustration 34

g02429279

5. Place the hydraulic lockout control in the RAISED position.

i04258937

Slope Operation

SMCS Code: 7000

WARNING

When traveling up or down a slope, travel slowly. The machine can tip at angles that are 15 degrees or more, which could cause serious injury or death. Refer to the Operation and Maintenance Manual for the proper traveling procedure.

WARNING

When traveling across a slope, travel slowly. The machine can tip at angles that are 10 degrees or more, which could cause serious injury or death. Refer to the Operation and Maintenance Manual for the proper traveling procedure.

Machines that are operating safely in various applications depend on these criteria: the machine model, configuration, machine maintenance, operating speed of the machine, conditions of the terrain, fluid levels and tire inflation pressures. The most important criteria are the skill and judgment of the operator.

A well trained operator that follows the instructions in the Operation and Maintenance Manual has the greatest impact on stability. Operator training provides a person with the following abilities: observation of working and environmental conditions, feel for the machine, identification of potential hazards and operating the machine safely by making appropriate decisions.

When you work on side hills and when you work on slopes, consider the following important points:

Speed of travel – At higher speeds, forces of inertia tend to make the machine less stable.

Roughness of terrain or surface – The machine may be less stable with uneven terrain.

Direction of travel – Avoid operating the machine across the slope. When possible, operate the machine up the slopes and operate the machine down the slopes. Place the heaviest end of the machine uphill when you are working on an incline.

Mounted equipment – Balance of the machine may be impeded by the following components: equipment that is mounted on the machine, machine configuration, weights and counterweights.

Nature of surface – Ground that has been newly filled with earth may collapse from the weight of the machine.

Surface material – Rocks and moisture of the surface material may drastically affect machine

traction and machine stability. Rocky surfaces may promote side slipping of the machine.

Slippage due to excessive loads – This may cause downhill tracks or downhill tires to dig into the ground, which will increase the angle of the machine.

Width of tracks or tires – Narrower tracks or narrower tires further increase the digging into the ground which causes the machine to be less stable.

Height of the working load of the machine – When the working loads are in higher positions, the stability of the machine is reduced.

Operated equipment – Be aware of performance features of the equipment in operation and the effects on machine stability.

Operating techniques – Keep all work tools low to the ground for optimum stability.

Machine systems have limitations on slopes – Slopes can affect the proper function and operation of the various machine systems. These machine systems are needed for machine control.

Note: Safe operation on steep slopes may require special machine maintenance. Excellent skill of the operator and proper equipment for specific applications are also required. Consult the Operation and Maintenance Manual sections for the proper fluid level requirements and intended machine use.

i01329161

Equipment Lowering with Engine Stopped

SMCS Code: 7000-II

Before lowering any equipment with the engine stopped, clear the area around the equipment of all personnel. The procedure to use will vary with the type of equipment to be lowered. Keep in mind most systems use a high pressure fluid or air to raise or lower equipment. The procedure will cause high pressure air, hydraulic, or some other media to be released in order to lower the equipment. Wear appropriate personal protective equipment and follow the established procedure in the Operation and Maintenance Manual, "Equipment Lowering with Engine Stopped" in the Operation Section of the manual.

i08118149

Sound Information and Vibration Information

SMCS Code: 7000

Sound Level Information

The declared dynamic operator sound pressure level is 77 dB(A) when “ISO 6396: 2008” is used to measure the value for an enclosed cab. The measurement was conducted at 70% of the maximum engine cooling fan speed. The sound level may vary at different engine cooling fan speeds. The measurement was conducted with the cab doors and the cab windows closed. The cab was properly installed and maintained.

The declared sound levels listed above include both measurement uncertainty and uncertainty due to production variation.

Hearing protection may be needed when the machine is operated with an open operator station for extended periods or in a noisy environment. Hearing protection may be needed when the machine is operated with a cab that is not properly maintained or when the doors and windows are open for extended periods or in a noisy environment.

Sound Level Information for Machines in European Union Countries and in Countries that Adopt the “EU Directives”

The dynamic operator sound pressure level is 77 dB (A) when “ISO6396: 2008” is used.

The average exterior sound power level is 93 dB(A) when the “ISO 6395 - Dynamic Test” procedure is used to measure the value for the standard machine.

The machine sound power level meets the criteria that are specified in “European Directive 2000/14 EC” modified by “2005/88/EC”.

The uncertainty is 1.2 dB(A) and meets “ISO 4871”. The sound pressure level at the operators ear had been measured according to “85/532/EWG”, “89/514/EWG”, and “95/27/EWG”. All measurements were carried out on an asphalted surface.

The declared sound levels listed above include both measurement uncertainty and uncertainty due to production variation.

Sound Level Information for Machines in Eurasian Economic Union Countries

The declared exterior sound power level L_{WA} is 93 dB (A) when the value is measured according to the dynamic test procedures and the conditions that are specified in “ISO 6395:2008”. The measurement was conducted at 70 % of the maximum engine cooling fan speed. The sound level may vary at different engine cooling fan speeds.

The declared dynamic operator sound pressure level is 77 dB(A) when “ISO 6396: 2008” is used to measure the value for an enclosed cab. The measurement was conducted at 70% of the maximum engine cooling fan speed. The sound level may vary at different engine cooling fan speeds. The measurement was conducted with the cab doors and the cab windows closed. The cab was properly installed and maintained.

The declared sound levels listed above include both measurement uncertainty and uncertainty due to production variation.

“The European Union Physical Agents (Vibration) Directive 2002/44/EC”

Vibration Data for Compact Track Excavator

Information Concerning Hand/Arm Vibration Level

When the machine is operated according to the intended use, the hand/arm vibration of this machine is below 2.5 m/s².

Information Concerning Whole Body Vibration Level

This section provides vibration data and a method for estimating the vibration level for Compact track excavators.

Note: Vibration levels are influenced by many different parameters. Many items are listed below.

- Operator training, behavior, mode and stress
- Job site organization, preparation, environment, weather and material
- Machine type, quality of the seat, quality of the suspension system, attachments and condition of the equipment

Safety Section
Sound Information and Vibration Information

It is not possible to get precise vibration levels for this machine. The expected vibration levels can be estimated with the information in Table 2 in order to calculate the daily vibration exposure. A simple evaluation of the machine application can be used.

Estimate the vibration levels for the three vibration directions. For typical operating conditions, use the average vibration levels as the estimated level. With an experienced operator and smooth terrain, subtract the Scenario Factors from the average vibration level in order to obtain the estimated vibration level. For aggressive operations and severe terrain, add the Scenario Factors to the average vibration level in order to obtain the estimated vibration level.

Note: All vibration levels are in meter per second squared.

Table 2

"ISO Reference Table A - Equivalent vibration levels of whole body vibration emission for earthmoving equipment."							
Machine Type	Typical Operating Activity	Vibration Levels			Scenario Factors		
		X axis	Y axis	Z axis	X axis	Y axis	Z axis
Compact Track Excavator	excavating	0,33	0,21	0,19	0,19	0,12	0,10
	hydraulic breaker application	0,49	0,28	0,36	0,20	0,13	0,17
	transfer	0,45	0,39	0,62	0,17	0,18	0,28

Note: Refer to "ISO/TR 25398 Mechanical Vibration - Guideline for the assessment of exposure to whole body vibration of ride on operated earthmoving machines" for more information about vibration. This publication uses data that is measured by international institutes, organizations, and manufacturers. This document provides information about the whole body exposure of operators of earthmoving equipment. Refer to Operation and Maintenance Manual, SEBU8257, "The European Union Physical Agents (Vibration) Directive 2002/44/EC" for more information about machine vibration levels.

Guidelines for Reducing Vibration Levels on Earthmoving Equipment

Properly adjust machines. Properly maintain machines. Operate machines smoothly. Maintain the conditions of the terrain. The following guidelines can help reduce the whole body vibration level:

1. Use the right type and size of machine, equipment, and attachments.
2. Maintain machines according to the manufacturer's recommendations.
 - a. Tire pressures
 - b. Brake and steering systems
 - c. Controls, hydraulic system, and linkages
3. Keep the terrain in good condition.
 - a. Remove any large rocks or obstacles.
 - b. Fill any ditches and holes.
 - c. Provide machines and schedule time in order to maintain the conditions of the terrain.
4. Keep the seat maintained and adjusted.
 - a. Adjust the seat and suspension for the weight and the size of the operator.
 - b. Inspect and maintain the seat suspension and adjustment mechanisms.
5. Perform the following operations smoothly.
 - a. Steer
 - b. Brake
 - c. Accelerate.
 - d. Shift the gears.
6. Move the attachments smoothly.
7. Adjust the machine speed and the route in order to minimize the vibration level.
 - a. Drive around obstacles and rough terrain.
 - b. Slow down when it is necessary to go over rough terrain.

8. Minimize vibrations for a long work cycle or a long travel distance.
 - a. Use machines that are equipped with suspension systems.
 - b. Use the ride control system on track-type excavators.
 - c. If no ride control system is available, reduce speed in order to prevent bounce.
 - d. Haul the machines between workplaces.
9. Less operator comfort may be caused by other risk factors. The following guidelines can be effective in order to provide better operator comfort:
 - a. Adjust the seat and adjust the controls in order to achieve good posture.
 - b. Adjust the mirrors in order to minimize twisted posture.
 - c. Provide breaks in order to reduce long periods of sitting.
 - d. Avoid jumping from the cab.
 - e. Minimize repeated handling of loads and lifting of loads.
 - f. Minimize any shocks and impacts during sports and leisure activities.

Sources

The vibration information and calculation procedure is based on "ISO/TR 25398 Mechanical Vibration - Guideline for the assessment of exposure to whole body vibration of ride on operated earthmoving machines". Harmonized data is measured by international institutes, organizations, and manufacturers.

This literature provides information about assessing the whole body vibration exposure of operators of earthmoving equipment. The method is based on measured vibration emission under real working conditions for all machines.

Check the original directive. This document summarizes part of the content of the applicable law. This document is not meant to substitute the original sources. Other parts of these documents are based on information from the United Kingdom Health and Safety Executive.

Refer to Operation and Maintenance Manual, SEBU8257, "The European Union Physical Agents (Vibration) Directive 2002/44/EC" for more information about vibration.

Consult your local Caterpillar dealer for more information about machine features that minimize vibration levels. Consult your local Cat dealer about safe machine operation.

Use the following web site in order to find your local dealer:

Caterpillar, Inc.
www.cat.com

i05374158

Operator Station

SMCS Code: 7300; 7301; 7325

Any modifications to the operator station should not project into the operator space. The addition of a fire extinguisher, and other equipment must be installed so that the defined operator space is maintained. Do not bring any items into the operator station. A lunch box or other loose items must be removed. Objects must not pose an impact hazard in rough terrain or in the event of a rollover.

Note: Apart from the operator, no other persons are allowed to ride on the machine.

i05615408

Guards (Operator Protection)

SMCS Code: 7000; 7150

There are different types of guards that are used to protect the operator. The machine and the machine application will determine the type of guard that has to be used. The decision regarding the necessary protective structures must be made by the machine owner. The machine owner must observe the national regulations and must inform the operator on the protective structure to be used in a specific work situation.

A daily inspection of the guards is required in order to check for structures that are bent, cracked, or loose. Never operate a machine with a damaged structure.

The operator becomes exposed to a hazardous situation if the machine is used improperly or if poor operating techniques are used. This situation can occur even though a machine is equipped with an appropriate protective guard. Follow the established operating procedures that are recommended for your machine.

Roll Over Protective Structure (ROPS)

The ROPS structure (if equipped) on your machine is designed, tested, and certified for that machine. Any alteration or any modification to the ROPS structure could weaken the structure. This places the operator into an unprotected environment. Modifications or attachments that cause the machine to exceed the weight that is stamped on the certification plate also place the operator into an unprotected environment. Excessive weight may inhibit the ROPS structure. The protection that is offered by the ROPS structure will be impaired if the ROPS structure has structural damage. Damage to the structure can be caused by an overturn, a falling object, a collision, etc.

Do not mount items (fire extinguishers, first aid kits, work lights, etc.) by welding brackets to the ROPS structure or by drilling holes in the ROPS structure. Welding brackets or drilling holes in the ROPS structures can weaken the structures. Consult your Cat dealer for mounting guidelines. The ROPS structure also fulfills the requirements of a Tip Over Protective Structure (TOPS).

Other Guards (If Equipped)

Protection from flying objects is required for special applications. Demolition applications is an example that requires special protection.

When a work tool that creates flying fragments is used, a Polycarbonate shield that is approved by Caterpillar has to be installed (optional equipment). A Polycarbonate shield fulfills the function of a front window but not of a front guard. However, the limited operating range has to be observed, which depends on the used work tool. Graphics 35 and 36 shows the limited operating range on the example of a hydraulic hammer.

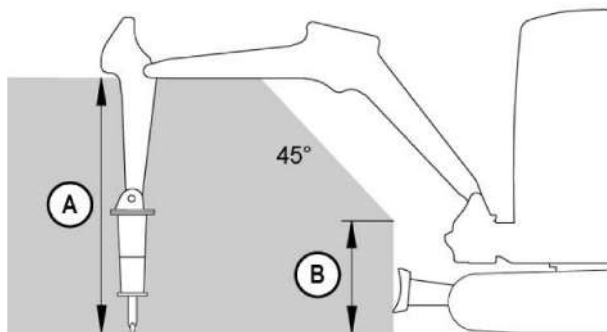

Illustration 35

g03392773

- (A) 120 cm (47 inch)
- (B) 50 cm (20 inch)

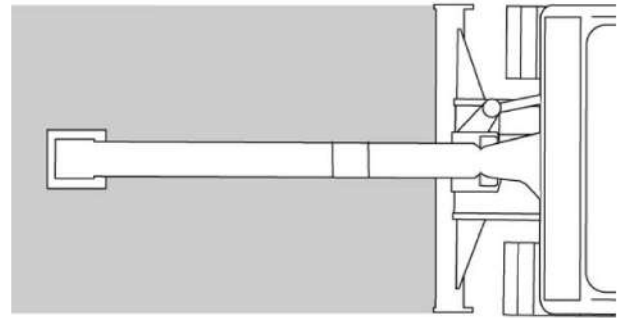

Illustration 36

g03392776

When visibility is restricted due to rain, snowfall, dust etc., the work has to be stopped, as the Polycarbonate shield is not equipped with a wiper. Resume work only if visibility is no longer restricted.

Note: Operating the machine in areas with danger from objects from the front and/or above is NOT permitted.

Additional guards may be required for specific applications or work tools. The Operation and Maintenance Manual for your machine or your work tool will provide specific requirements for the guards. Consult your Cat dealer for additional information.

Product Information Section

General Information

i08118185

Specifications

SMCS Code: 7000

Intended Use

The intended use of this machine is for excavating with an approved bucket or working with approved work tools. The machine should be operated with the undercarriage in a stationary position since the upper structure is normally capable of 360 degree swing with mounted equipment.

Every other application is regarded as not designated for the use of the machine. Caterpillar will not be liable for damage resulting from use other than mentioned above. The user alone will bear the risk. Designated use also include observing the instructions set forth in the Operation and Maintenance Manual and observing the maintenance and service conditions.

The safety of the machine can be negatively affected by carrying out machine modifications without proper authority and by using spare parts, equipment, attachments, and optional equipment which have not been checked and released by Caterpillar. Caterpillar will not be liable for damage resulting from this.

Caterpillar shall not be liable for personal injury and/or damage to property caused by failure to observe the safety instructions and the Operator Manual, and by the negligence of the duty to exercise due care when:

- handling
- operating
- servicing and carrying out maintenance work
- repairing the machine.

This is also applicable in those cases in which special attention has not been drawn to the duty to exercise due care, in the safety instructions, the Operation and Maintenance Manual.

Read and understand the Operation and Maintenance Manual before starting up, servicing or repairing the machine. Observe the safety instructions!

The machine may not be used for transport jobs on public roads.

Operating the machine in areas with danger of flying fragments is only permitted with a polycarbonate shield installed. Operating the machine in areas with danger from objects from the front and/or above is NOT permitted.

Hammer operation is only allowed in specified areas.

Expected Life

The expected life, defined as total machine hours, of this machine is dependent upon many factors including the machine owner's desire to rebuild the machine back to factory specifications. The expected life interval of this machine is 10,000 service hours. The expected life interval corresponds to the service hours to engine overhaul or replacement. Service hours to engine overhaul or replacement may vary based on overall machine duty cycle. At the expected life interval, remove the machine from operation and consult your Cat[®] dealer for inspect, repair, rebuild, install remanufactured, install new components, or disposal options and to establish a new expected life interval. If a decision is made to remove this machine from service, refer to Operation and Maintenance Manual, "Decommissioning and Disposal".

The following items are required to obtain an economical expected life of this machine:

- Perform regular preventive maintenance procedures as described in the Operation and Maintenance Manual.
- Perform machine inspections as described in the Operation and Maintenance Manual and correct any problems discovered.
- Perform system testing as described in the Operation and Maintenance Manual and correct any problems discovered.
- Ensure that machine application conditions comply with Caterpillar's recommendations.
- Ensure that the operating weight does not exceed limits set by manufacturer.

- Ensure that all frame cracks are identified, inspected, and repaired to prevent further development.

Specification Data

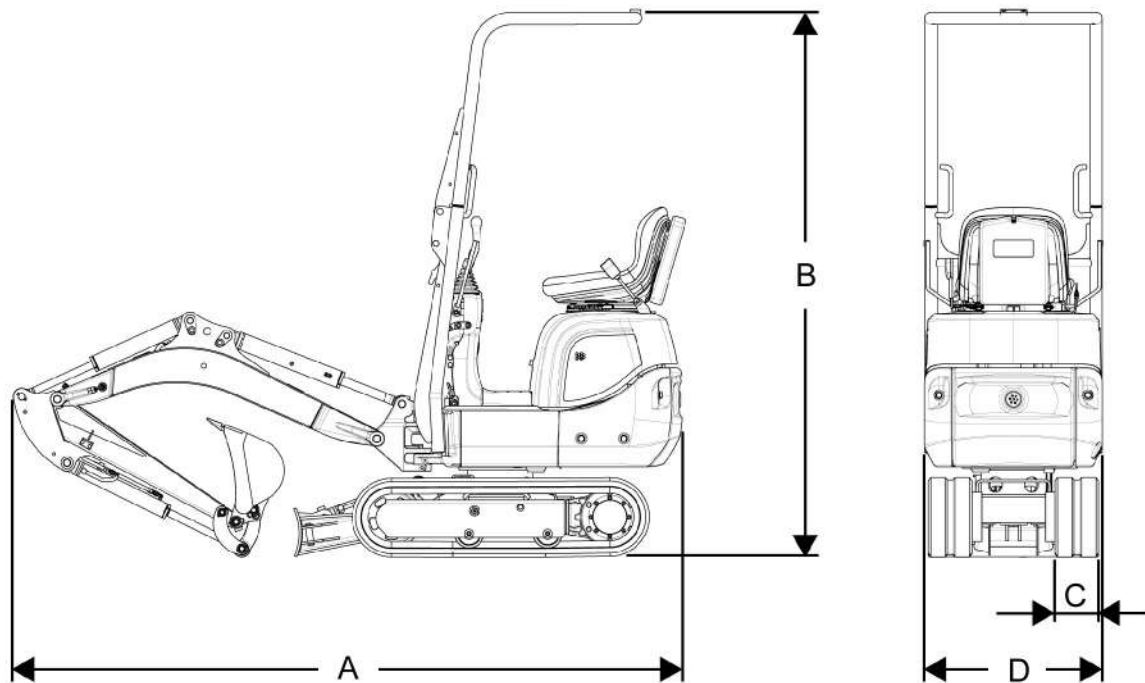

Illustration 37

g02444260

Table 3

300.9D with Rollbar (ROPS)	
Service weight	1087 kg (2396 lb)
Transport length (A)	2747 mm (9 ft)
Height (transport position) (B)	2248 mm (7 ft 5 inch)
Track width (C)	180 mm (7 inch)
Width ⁽¹⁾ (D)	730/860 mm (2 ft 5 inch/2 ft 10 inch)

(1) Retracted/extended telescopic undercarriage

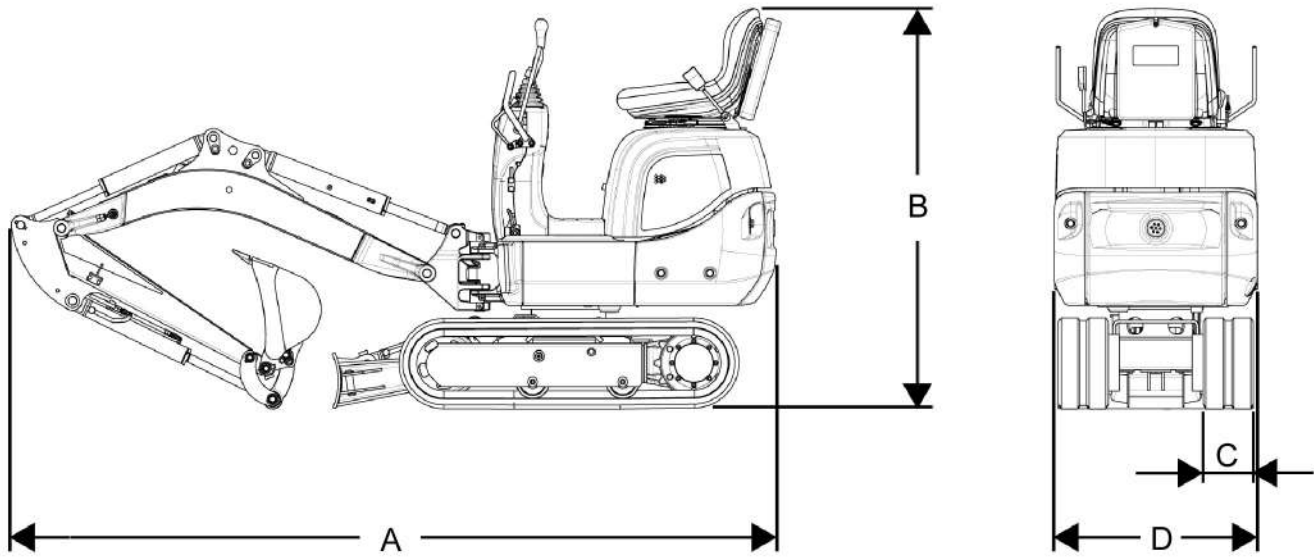

Illustration 38

g02444356

Table 4

300.9D without Rollbar (ROPS)	
Service weight	1029 kg (2269 lb)
Transport length (A)	2747 mm (9 ft)
Height (transport position) (B)	1436 mm (4 ft 9 inch)
track width (C)	180 mm (7 inch)
Width ⁽¹⁾ (D)	730/860 mm (2 ft 5 inch/2 ft 10 inch)

(1) Retracted/extended telescopic undercarriage

Working Ranges

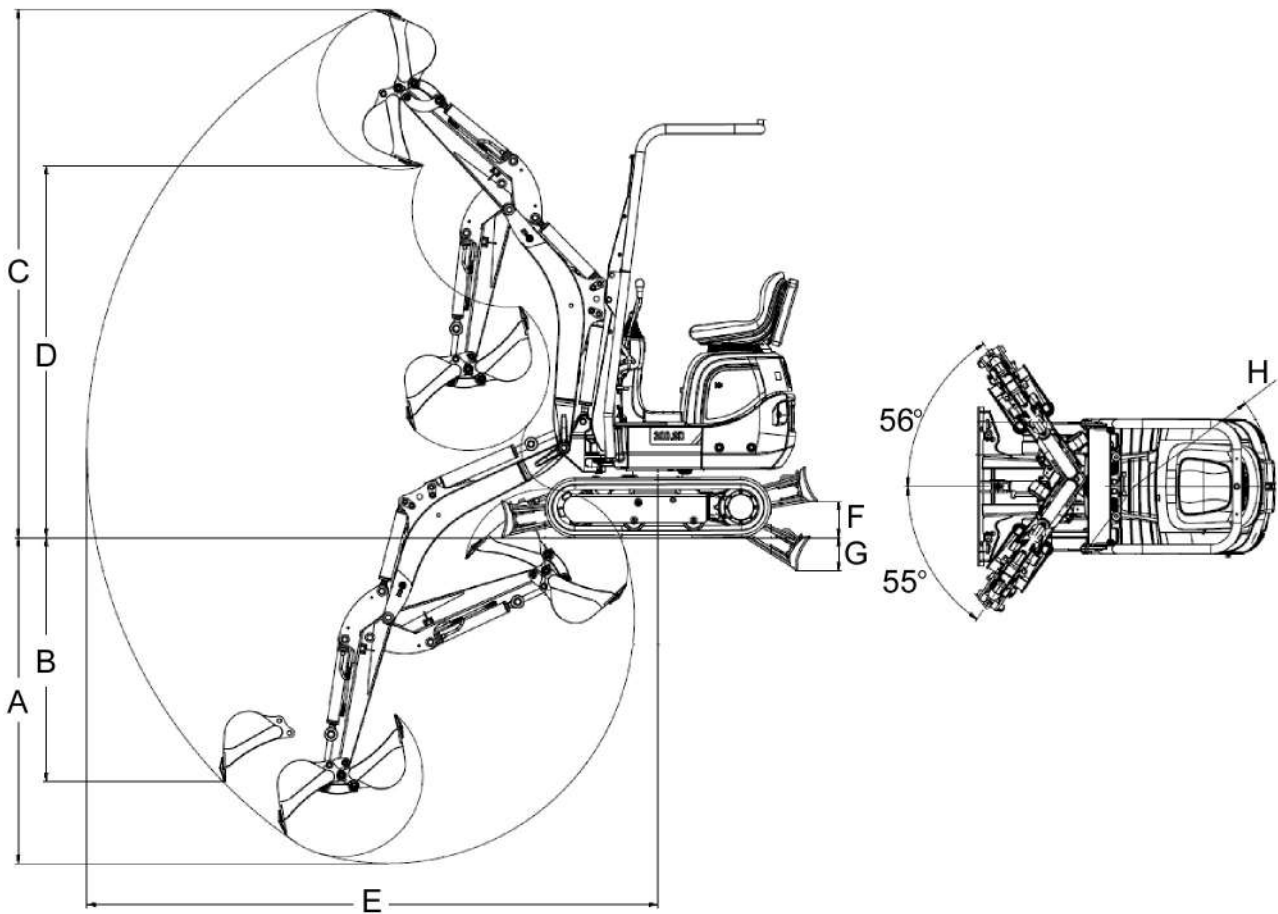

Illustration 39

g02451237

Table 5

300.9D	
Maximum digging depth (A)	1766 mm (5 ft 9.5 inch)
Maximum verticle digging depth (B)	1320 mm (4 ft 4 inch)
Maximum digging height (C)	2853 mm (9 ft 4 inch)
Maximum dump height (D)	2008 mm (6 ft 7 inch)
Maximum digging radius (E)	3092 mm (10 ft 2 inch)
Blade raised (F)	194 mm (8 inch)

(continued)

(Table 5, contd)

Blade lowered (G)	178 mm (7 inch)
Minimum tail end swing radius (H)	747 mm (2 ft 5 inch)
Maximum breakout force at bucket tooth	8.99 kN (2021 lb-ft)
Maximum tear out force	4.51 kN (1013 lb-ft)
Maximum reach at ground level	3040 mm (10 ft)
Maximum tail end lateral projection (90° rotation of upper carriage) ⁽¹⁾	397/317 mm (1 ft 3.6inch/1 ft 0.5 inch)
Maximum boom displacement to bucket center (right-hand side)	287 mm (11 ft)
Maximum boom displacement to bucket center (left-hand side)	242 mm (9 ft 5 inch)
Stick length	890 mm (2 ft 11 inch)

⁽¹⁾ Retracted/extended adjustable gauge undercarriage

Operating Radius of 300.9D VPS with Connected Power Pack HPU 300

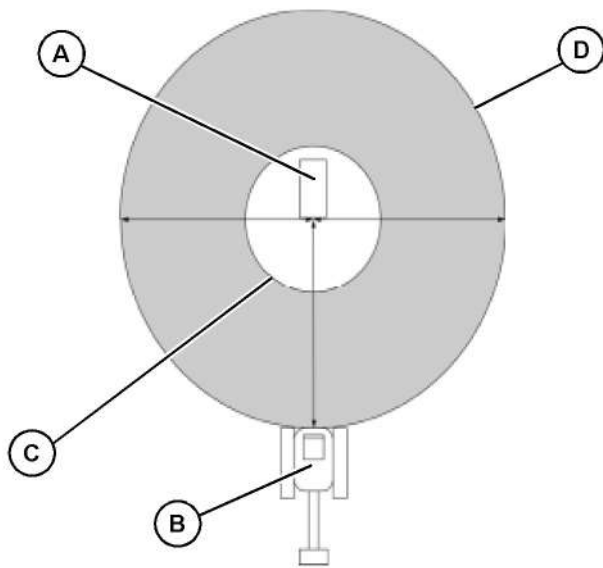

Illustration 40

g06100223

Table 6

Position	Function
(A)	Power Pack HPU 300
(B)	Mini Hydraulic Excavator 300.9D VPS
(C)	Minimum operating radius with connected power pack 1.5 m (4 ft 11 inch)
(D)	Maximum operating radius with connected power pack 10.0 m (32 ft 10 inch)
	Minimum bending radius of power pack hydraulic hoses: 300 mm (12 inch)

- The power pack must be at the same level as the excavator.
- Do not pull the power pack by the hydraulic hoses.
- The operator must have permanent visual contact with the power pack.
- Do not travel across hydraulic hoses.
- The protective hoses must be on the excavator side of the hydraulic hose and must not be removed.
- Do not squeeze hydraulic hoses.
- Do not put hydraulic hoses over edges.
- Do not put anything down on the hydraulic hoses.
- Do not put the connecting cable over edges.

Engine

Table 7

Model	Serial Number Prefix	Engine
300.9D	LJM	3TNV70
	LJ2	3TNV74F
300.9D VPS	DW2	3TNV70
	TGP	3TNV74F

i05615698

Boom/Stick/Bucket Combinations

SMCS Code: 6000; 6700

This machine can be equipped with different work tools in order to meet the needs of various applications.

Note: The selection of a compatible boom-stick-bucket combination is a guide. Work tools, uneven ground conditions, soft ground conditions, or poor ground conditions have effects on machine performance. The operator is responsible for being aware of these effects.

Using work tools of other manufactures, or work tools which have been released for other excavators, can reduce the machines output and stability considerably, and can also damage to the machine and injuries to the operator or other personnel.

Consult your Cat dealer for information on selecting the correct boom-stick-bucket combination.

The following table shows available work tools. Select the most suitable work tool according to the working conditions and according to the type of work that is being done. Always compare the weight of the work tool and its maximum payload with the indications in the lift capacity table. Never exceed the maximum payload stated in the lift capacity table.

Table 8

300.9D Buckets				
	Width	Weight	Capacity	Teeth
Backhoe bucket	250 mm (10 inch)	15 kg (33 lb)	14 L (4 US gal)	3
Backhoe bucket	370 mm (14.5 inch)	17 kg (38 lb)	18 L (5 US gal)	3
Backhoe bucket	370 mm (14.5 inch)	19 kg (42 lb)	24 L (6.5 US gal)	3
Bucket	700 mm (27.5)	25.5 kg (54 lb)	27 L (7 US gal)	0

i04925879

Lifting Capacities

SMCS Code: 7000

WARNING

Failure to comply to the rated load can cause possible personal injury or property damage. Review the rated load of a particular work tool before performing any operation. Make adjustments to the rated load as necessary for non-standard configurations.

Note: Rated loads are based upon a standard machine with the following conditions:

- lubricants
- full fuel tank
- ROPS
- 75 kg (165 lb) operator

Rated loads will vary with different work tools. Consult your Caterpillar dealer regarding the rated load for specific work tools.

Note: Rated loads should be used as a guide. Work tools, uneven ground conditions, soft ground conditions, or poor ground conditions have effects on rated loads. The operator is responsible for being aware of these effects.

Special hazards (toxic gases, ground conditions, etc.) require special precautions. The operator must determine whether special hazards exist in each application. The operator shall perform the appropriate steps in order to eliminate the hazard. The operator shall perform the appropriate steps in order to reduce the hazard.

For North American applications, the rated operating load is defined by "SAE J1097 1988". For European applications, the rated operating load is defined by "ISO 10567 1992". The rated operating load is defined as the lower value of 75% of the static tipping capacity or 87% of the hydraulic lift capacity.

Note: European regulations require the machine to be equipped with a mechanism that locks the dozer blade into position if the dozer blade is used to increase stability. If a mechanism that locks the dozer blade into position is not installed, use the values that are given in the tables for the machine when the blade is up. If a mechanism that locks the dozer blade into position is installed, use the values that are given in the tables for the machine when the blade is down.



Illustration 41

g02473698

(H) Lift Point Height
(R) Lift Point Radius

Table 9

300.9D Lifting Capacities with the blade up All lifting capacities are in kilograms and pounds. ⁽¹⁾							
Lifting point in front of swing center.							
(H)	(R)					Maximum Radius (m/ft)	
	1.0 m 3.3 ft	1.5 m 4.9 ft	2.0 m 6.6 ft	2.5 m 8.2 ft			
2.43 m 7.98 ft					216 ⁽²⁾ 477 ⁽²⁾	1.41 4.61	
2.0 m 6.6 ft			203 ⁽²⁾ 448 ⁽²⁾		205 ⁽²⁾ 453 ⁽²⁾	2.03 6.64	
1.5 m 4.9 ft			189 ⁽²⁾ 416 ⁽²⁾		163 358	2.40 7.86	
1.0 m 3.3 ft		247 ⁽²⁾ 544 ⁽²⁾	212 469	151 332	142 314	2.59 8.49	
0.5 m 1.6 ft		311 685	204 450	147 325	135 298	2.65 8.70	
0	570 1257	296 653	197 434	145 319	137 303	2.60 8.52	
-0.5 m -1.6 ft	561 ⁽²⁾ 1236 ⁽²⁾	292 644	194 428		146 ⁽²⁾ 323 ⁽²⁾	2.41 7.91	
-1.0 m -3.3 ft	418 ⁽²⁾ 922 ⁽²⁾	243 ⁽²⁾ 536 ⁽²⁾	149 ⁽²⁾ 328 ⁽²⁾		138 ⁽²⁾ 304 ⁽²⁾	2.05 6.73	

⁽¹⁾ Lift capacities are based on "ISO 10567" standards. The listed capacities do not exceed 87 percent of the hydraulic lifting capacity or 75 percent of the tipping capacity. Weight of all lifting accessories must be subtracted from the lifting capacities.

⁽²⁾ Capacity is limited by hydraulics rather than by a tipping load.

Product Information Section
Lifting Capacities

Table 10

300.9D Lifting Capacities with the blade down All lifting capacities are in kilograms and pounds. ⁽¹⁾							
Lifting point in front of swing center.							
(H)	(R)					Maximum Radius (m/ft)	
	1.0 m 3.3 ft	1.5 m 4.9 ft	2.0 m 6.6 ft	2.5 m 8.2 ft			
2.43 m 7.98 ft					216 ⁽²⁾ 477 ⁽²⁾	1.41 4.61	
2.0 m 6.6 ft			203 ⁽²⁾ 448 ⁽²⁾		205 ⁽²⁾ 453 ⁽²⁾	2.03 6.64	
1.5 m 4.9 ft			189 ⁽²⁾ 416 ⁽²⁾		191 ⁽²⁾ 420 ⁽²⁾	2.40 7.86	
1.0 m 3.3 ft		247 ⁽²⁾ 544 ⁽²⁾	217 ⁽²⁾ 478 ⁽²⁾	185 ⁽²⁾ 407 ⁽²⁾	177 ⁽²⁾ 391 ⁽²⁾	2.59 8.49	
0.5 m 1.6 ft		366 ⁽²⁾ 807 ⁽²⁾	247 ⁽²⁾ 544 ⁽²⁾	184 ⁽²⁾ 407 ⁽²⁾	166 ⁽²⁾ 365 ⁽²⁾	2.65 8.70	
0	678 ⁽²⁾ 1495 ⁽²⁾	379 ⁽²⁾ 835 ⁽²⁾	247 ⁽²⁾ 546 ⁽²⁾	171 ⁽²⁾ 377 ⁽²⁾	155 ⁽²⁾ 343 ⁽²⁾	2.60 8.52	
-0.5 m -1.6 ft	561 ⁽²⁾ 1236 ⁽²⁾	325 ⁽²⁾ 718 ⁽²⁾	215 ⁽²⁾ 475 ⁽²⁾		146 ⁽²⁾ 323 ⁽²⁾	2.41 7.91	
-1.0 m -3.3 ft	418 ⁽²⁾ 922 ⁽²⁾	243 ⁽²⁾ 536 ⁽²⁾	149 ⁽²⁾ 328 ⁽²⁾		138 ⁽²⁾ 304 ⁽²⁾	2.05 6.73	

(1) Lift capacities are based on "ISO 10567" standards. The listed capacities do not exceed 87 percent of the hydraulic lifting capacity or 75 percent of the tipping capacity. Weight of all lifting accessories must be subtracted from the lifting capacities.

(2) Capacity is limited by hydraulics rather than by a tipping load.

Table 11

300.9D Lifting Capacities with the blade at the rear of the machine All lifting capacities are in kilograms and pounds. ⁽¹⁾							
Lifting point in front of swing center.							
(H)	(R)					Maximum Radius (m/ft)	
	1.0 m 3.3 ft	1.5 m 4.9 ft	2.0 m 6.6 ft	2.5 m 8.2 ft			
2.43 m 7.98 ft					216 ⁽²⁾ 477 ⁽²⁾	1.41 4.61	
2.0 m 6.6 ft			203 ⁽²⁾ 448 ⁽²⁾		205 ⁽²⁾ 453 ⁽²⁾	2.03 6.64	
1.5 m 4.9 ft			189 ⁽²⁾ 416 ⁽²⁾		175 386	2.40 7.86	
1.0 m 3.3 ft		247 ⁽²⁾ 544 ⁽²⁾	217 ⁽²⁾ 478 ⁽²⁾	162 358	154 339	2.59 8.49	
0.5 m 1.6 ft		335 738	220 484	159 351	146 322	2.65 8.70	
0	618 1363	320 705	213 469	156 344	148 327	2.60 8.52	

(continued)

(Table 11, contd)

300.9D Lifting Capacities with the blade at the rear of the machine						
All lifting capacities are in kilograms and pounds.⁽¹⁾						
-0.5 m	433 ⁽²⁾	316	210		146 ⁽²⁾	2.41
-1.6 ft	1236 ⁽²⁾	696	462		323 ⁽²⁾	7.91
-1.0 m	418 ⁽²⁾	243 ⁽²⁾	149 ⁽²⁾		138 ⁽²⁾	2.05
-3.3 ft	922 ⁽²⁾	536 ⁽²⁾	328 ⁽²⁾		304 ⁽²⁾	6.73

⁽¹⁾ Lift capacities are based on "ISO 10567" standards. The listed capacities do not exceed 87 percent of the hydraulic lifting capacity or 75 percent of the tipping capacity. Weight of all lifting accessories must be subtracted from the lifting capacities.

⁽²⁾ Capacity is limited by hydraulics rather than by a tipping load.

Identification Information

i08118553

Plate Locations and Film Locations

SMCS Code: 1000; 7000

The Product Identification Number (PIN) will be used to identify a powered machine that is designed for an operator to ride.

Cat® products such as engines, transmissions, and major attachments that are not designed for an operator to ride are identified by Serial Numbers.

The regional certification plate is used to verify that the product conforms to all of the requirements that were established by a country or a group of countries. The product is tested by a certified testing group in order to verify conformance.

For quick reference, record the identification numbers in the spaces that are provided below the illustration.

Product Identification Number (PIN) Plate

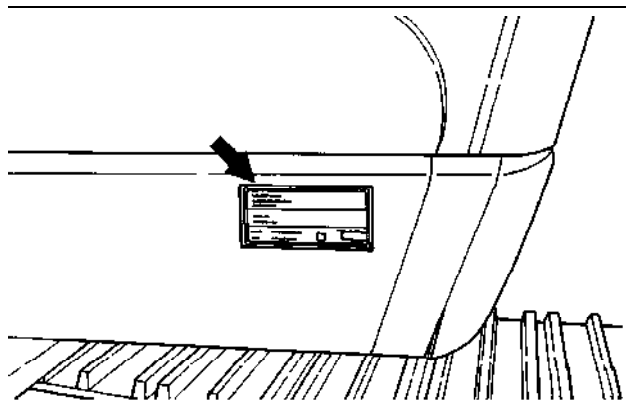

Illustration 42

g00675011

The PIN plate is positioned on the front of the machine, close to the operator compartment.

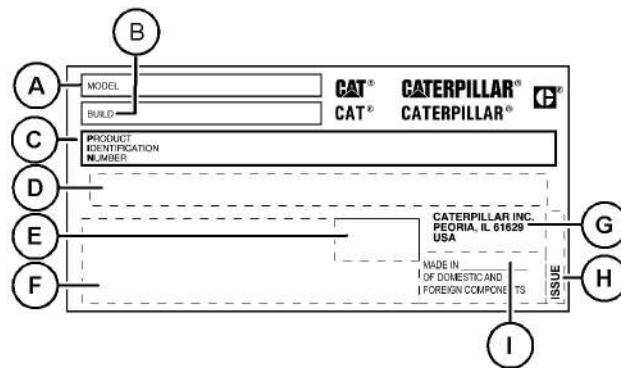

Illustration 43

g06201159

Manufacturer Name and Address _____

Model (A) _____

Build (B) _____

Product Identification Number (C) _____

Bar Code (D) _____

Month and Year of Manufacture Plate (If Required) (E) _____

Regional Certification Plate (If Required) (F) _____

Address of Manufacturer (G) _____

Issue (H) _____

Country of Origin Info Plate (If Required) (I) _____

Local regulation may require documentation of the month and/or year of manufacture in the Operation and Maintenance Manual. Comply with these regulations.

European Union



Illustration 44 g06201193

This plate is positioned on the bottom left side of the plate for the PIN.

Note: The CE plate is on machines that are certified to the European Union requirements that were effective at that time.

For machines compliant to 2006/42/EC, the following information is stamped onto the CE plate. For quick reference, record this information in the spaces that are provided below.

- Engine Power Primary Engine (kW) _____
- Engine Power for Additional Engine (kW) (If Equipped) _____
- Typical Machine Operating Weight for European Market (kg) _____
- Year of Construction _____
- Machine Type _____

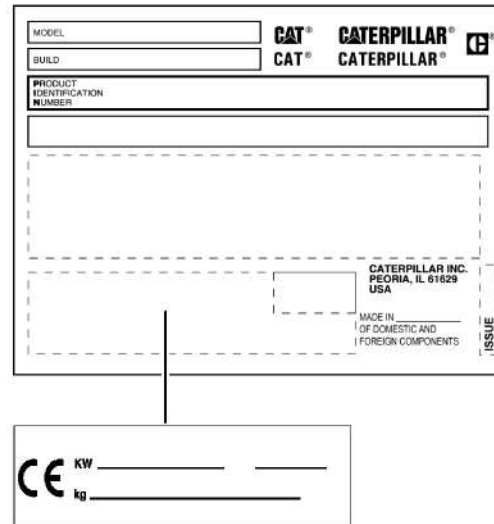

Illustration 45 g06201198

This plate is positioned on the bottom left side of the plate for the PIN.

Note: The CE plate is on machines that are certified to the European Union requirements that were effective at that time.

For machines compliant to 98/37/EC and 89/392/EEC, the following information is stamped onto the CE plate. For quick reference, record this information in the spaces that are provided below.

- Engine Power Primary Engine (kW) _____
- Typical Machine Operating Weight for European Market (kg) _____
- Year _____

For manufacturer name and address and the country of origin, see the PIN plate.

Eurasian Economic Union

For machines compliant to the Eurasian Economic Union requirements, the EAC mark plate is positioned near the Product Identification Number (PIN) plate (see Product Information Section of the machine Operation and Maintenance Manual). The EAC mark plate is placed on machines certified to the Eurasian Economic Union requirements effective at the time of market entry.



Illustration 46

g06094564

The Month and Year of Manufacture are on the PIN plate.

Manufacturer Information

Manufacturer:

Caterpillar Inc.,
100 N.E. Adams Street
Peoria, Illinois 61629, USA

Entity authorized by the manufacture at the territory
of Eurasian Economic Union.

Caterpillar Eurasia LLC
75, Sadovnicheskaya Emb.
Moscow 115035, Russia

Certification

Sound Certification

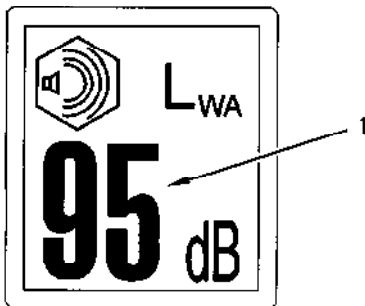

Illustration 47

g00919897

A typical example of this label is shown. Your machinery may have a different value.

If equipped, the certification label is used to verify the requirements of environmental sound of the European Union. The value (1) that is listed on the label indicates the guaranteed exterior sound power level L_{WA} at the time of manufacture for the conditions that are specified in "2000/14/EC".

i08085827

Emissions Certification Film

SMCS Code: 1000; 7000; 7405

Consult your Cat dealer for an Emission Control
Warranty Statement.

The emission certification film is on the engine.

Declaration of Conformity

SMCS Code: 1000; 7000

Product Information Section
Declaration of Conformity

Table 12

An EC Declaration of Conformity document was provided with the machine if it was manufactured to comply with specific requirements for the European Union. In order to determine the details of the applicable Directives, review the complete EC Declaration of Conformity provided with the machine. The extract shown below from an EC Declaration of Conformity for machines that are declared compliant to "2006/42/EC" applies only to those machines originally "CE" marked by the manufacturer listed and which have not since been modified.

EC DECLARATION OF CONFORMITY OF MACHINERY

Manufacturer: Wacker Neuson Linz GmbH, Haidfeldstr. 37, A-4060 Linz-Leonding

Product

Description:	Generic Denomination:	Earth-moving Equipment	
	Machine Designation	Hydraulic Excavator	
	Model/Type:	300.9D	
	Serial Number:		
	Output (kW):	9.9 kW	for engine 3TNV70-VNS
		11.6 kW	for engine 3TNV74F-SNNS
	Measured sound power level:	93.3 dB (A)	
	Guaranteed sound power level:	93 dB (A)	

Declaration of conformity

Notified body according to Directive 2006/42/EC, appendix XI:

DGUV Test-, Prüf- und Zertifizierungsstelle

Fachbereich Bauwesen, Landsberger Str. 309, 80687 Munich, Germany

Distinguishing EU number 0515

For 2000/14/EG notified body involved in procedure

TÜV SÜD Industrie Service GmbH
Westendstr. 199
D-80686 Munich

Directives and standards

We hereby declare that this product corresponds to the relevant regulations and requirements of the following Directives and standards:

2006/42/EG, 2005/88/EG, 2000/14/EG, 2014/30/EU, 2017/53/EU (if telematics option is installed) Appendix VIII;

DIN EN ISO 12100:2010, DIN EN 474-1:2006+A1:2009, DIN EN 474-6:2010 (except 5.2.3 AND 5.2.5), DIN EN ISO 3471:2010

Signature

Date:

Name/Position

Note: The above information was correct as of **March 2011**, but may be subject to change, please refer to the individual declaration of conformity issued with the machine for exact details.

Work Tool Declaration of Conformity

Table 13

An EC Declaration of Conformity document was provided with the machine if it was manufactured to comply with specific requirements for the European Union. In order to determine the details of the applicable Directives, review the complete EC Declaration of Conformity provided with the machine. The extract shown below from an EC Declaration of Conformity for machines that are declared compliant to "2006/42/EC" applies only to those machines originally "CE" marked by the manufacturer listed and which have not since been modified.

EC DECLARATION OF CONFORMITY OF MACHINERY

Manufacturer: Caterpillar Inc., 100 N.E. Adams Street, Peoria, Illinois 61629, USA

Person authorized to compile the Technical File and to communicate relevant part (s) of the Technical File to the Authorities of European Union Member States on request:

Standards & Regulations Manager, Caterpillar France S.A.S,
40 Avenue Leon-Blum, 38000 Grenoble, France

I, the undersigned, _____, hereby certify that the construction equipment specified hereunder

Description:	Generic Denomination:	Earth-moving Equipment
	Function:	Hydraulic Bucket
	Model/Type:	Hydraulic Ditch Cleaning Bucket
	Serial Number:	
	Commercial Name:	Caterpillar

Fulfills all the relevant provisions of the following Directives

Directives	Notified Body	[CTE_CURSOR]Document No.
2000/14/EC amended by 2005/88/EC, Note (1)		
2006/42/EC	N/A	
2004/108/EC	N/A	

Note (1) Annex - _____ Guaranteed Sound Power Level - _____ dB (A)
 Representative Equipment Type Sound Power Level - _____ dB (A)
 Engine Power per _____ - _____ kW Rated engine speed - _____ rpm
 Technical Documentation accessible through person listed above authorized to compile the Technical File

Done at:

Signature

Date:

Name/Position

Note: The above information was correct as of **December 2009**, but may be subject to change, please refer to the individual declaration of conformity issued with the machine for exact details.

Operation Section

Before Operation

i04267450

Mounting and Dismounting

SMCS Code: 6700; 7000

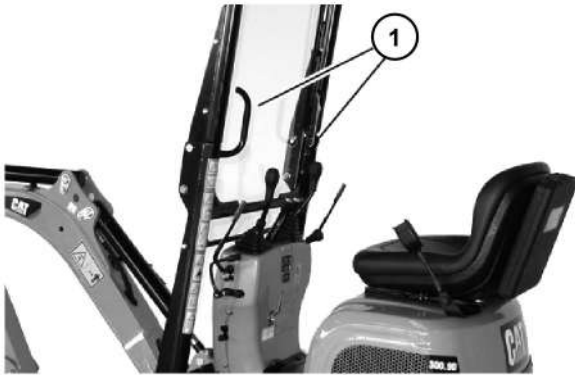

Illustration 48

g02475250

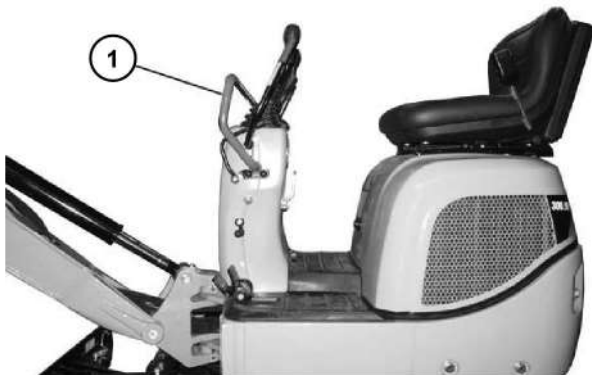

Illustration 49

g02475256

Use handholds whenever you mount the machine. Use handholds whenever you dismount the machine. Before you mount the machine, clean the handholds. Inspect the handholds. Make all necessary repairs.

Face the machine whenever you mount the machine and whenever you dismount the machine. Maintain a two-point contact with the ground/track and with the handhold (1).

Note: Do not use any of the operator/control levers as a handhold.

Do not mount a moving machine. Do not dismount a moving machine. Never jump off the machine. Do not try to mount the machine when you carry tools or supplies. Do not try to dismount the machine when you are carrying tools or supplies. Do not use any controls as handholds when you mount or dismount the machine.

Machine Access System Specifications

The machine access system has been designed to meet the intent of the technical requirements in "ISO 2867 Earth-moving Machinery – Access Systems". The access system provides for operator access to the operator station and to conduct the maintenance procedures described in Maintenance section.

i05615576

Daily Inspection

SMCS Code: 1000; 6319; 6700; 7000

NOTICE

Accumulated grease and oil on a machine is a fire hazard. Remove this debris with steam cleaning or high pressure water, at least every 1000 hours or each time any significant quantity of oil is spilled on a machine.

Refer to the Maintenance Section for the detailed procedures. Refer to the Maintenance Interval Schedule for a complete list of scheduled maintenance.

Inspect the hydraulic system for leaks. Inspect the hydraulic cylinders and inspect the cylinder rods and seals for damage or for excessive wear. Inspect the linkage and the work tool for damage or for excessive wear. Inspect the linkage for any missing or deformed pins. Make any necessary repairs.

Inspect the following additional components:

- the hydraulic tank
- the hoses
- the tubes
- the plugs
- the connecting joints
- the hydraulic fittings

Correct any leaks in the hydraulic system.

Inspect the final drives for leaks. Make any necessary repairs. Check the hydraulic oil level if you see leakage.

Inspect the tracks for deep cracks, or steel cords that are cut.

Inspect the lights for broken bulbs and for broken lenses. Replace any broken components.

Inspect the engine compartment for any trash buildup. Remove any trash buildup from the engine compartment.

Inspect the cooling system for any leaks, for faulty hoses, and for any trash buildup. Correct any leaks, and remove any trash from the radiator.

Inspect all of the belts for the engine attachments. Replace any belts that are worn, frayed, or broken.

Inspect the air filter housing for cracks, loose clamps, or broken tubing.

Inspect the exhaust system for loose connections or loose clamps.

Make sure that all covers and guards are securely attached. Inspect the covers and the guards for damage.

Inspect the handholds. Clean the handholds. Make any necessary repairs.

Inspect the polycarbonate shield for damage. Tighten any loose bolts on the ROPS. If repairs are needed, consult your Cat dealer.

Inspect the operator station for trash buildup. Check for trash buildup under the floor mat. Keep these areas clean.

Inspect the foot pedals for proper operation. Remove any dirt buildup in and around the foot pedals. Lubricate the springs of the foot pedals. Replace any missing hardware.

Inspect the operator station for the following conditions:

- Broken lenses on the gauges
- Broken indicator lights
- Broken switches
- Other broken components

Adjust the rearview mirrors (if equipped) for the best operator vision.

Machine Operation

i04301133

Seat

SMCS Code: 5258-025; 7312-025; 7324; 7327

Note: Check for correct seat adjustment at the beginning of each work period.

Do not adjust the seat while you are operating the machine. Always ensure that the seat has locked into position after any adjustments are made.



Illustration 50

g02465407

Pull up on the fore/aft lever (1). Hold up the lever and slide the seat forward or backward to the desired position. Release the lever in order to lock the seat into position.

The seat should be adjusted so that full travel of the controls and pedals is allowed. Adjusting the seat should only be done while the operator is seated against the back of the seat.

i04301332

Seat Belt

SMCS Code: 7327

Note: If this machine was equipped with a ROPS, the machine was equipped with a seat belt when the machine was shipped from Caterpillar. At the time of installation, the seat belt and the instructions for installation of the seat belt meet the SAE J386 and ISO 6683 standards. Consult your Cat dealer for all replacement parts.

Always check the condition of the seat belt and the condition of the mounting hardware before you operate the machine.

Seat Belt Adjustment for Retractable Seat Belts (Machines equipped with ROPS)

Fastening The Seat Belt

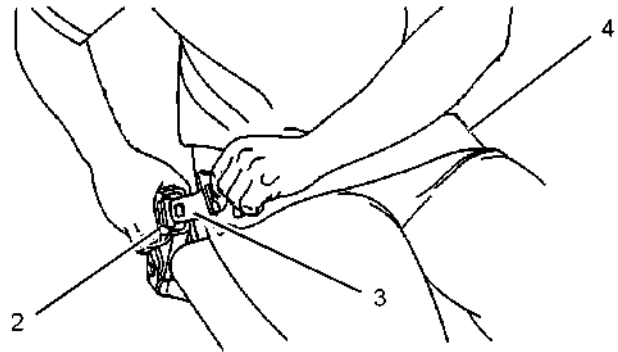

Illustration 51

g02475770

WARNING

When using retractable seat belts, do not use seat belt extensions, or personal injury or death can result.

The retractor system may or may not lock up depending on the length of the extension and the size of the person. If the retractor does not lock up, the seat belt will not retain the person.

Pull seat belt (4) out of the retractor in a continuous motion.

Fasten the seat belt catch (3) into buckle (2), until the seat belt clicks with an audible click. Make sure that the seat belt is placed low across the lap of the operator.

The retractor will adjust the belt length and the retractor will lock in place. The comfort ride sleeve will allow the operator to have limited movement.

Releasing The Seat Belt

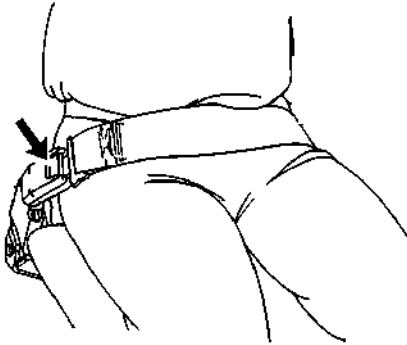

Illustration 52

g02475772

Push the release button on the buckle in order to release the seat belt. The seat belt will automatically retract into the retractor.

i07548961

Operator Controls

SMCS Code: 7300; 7301; 7451

Note: Your machine may not be equipped with all the controls that are described in this topic.

Operation Section
Operator Controls

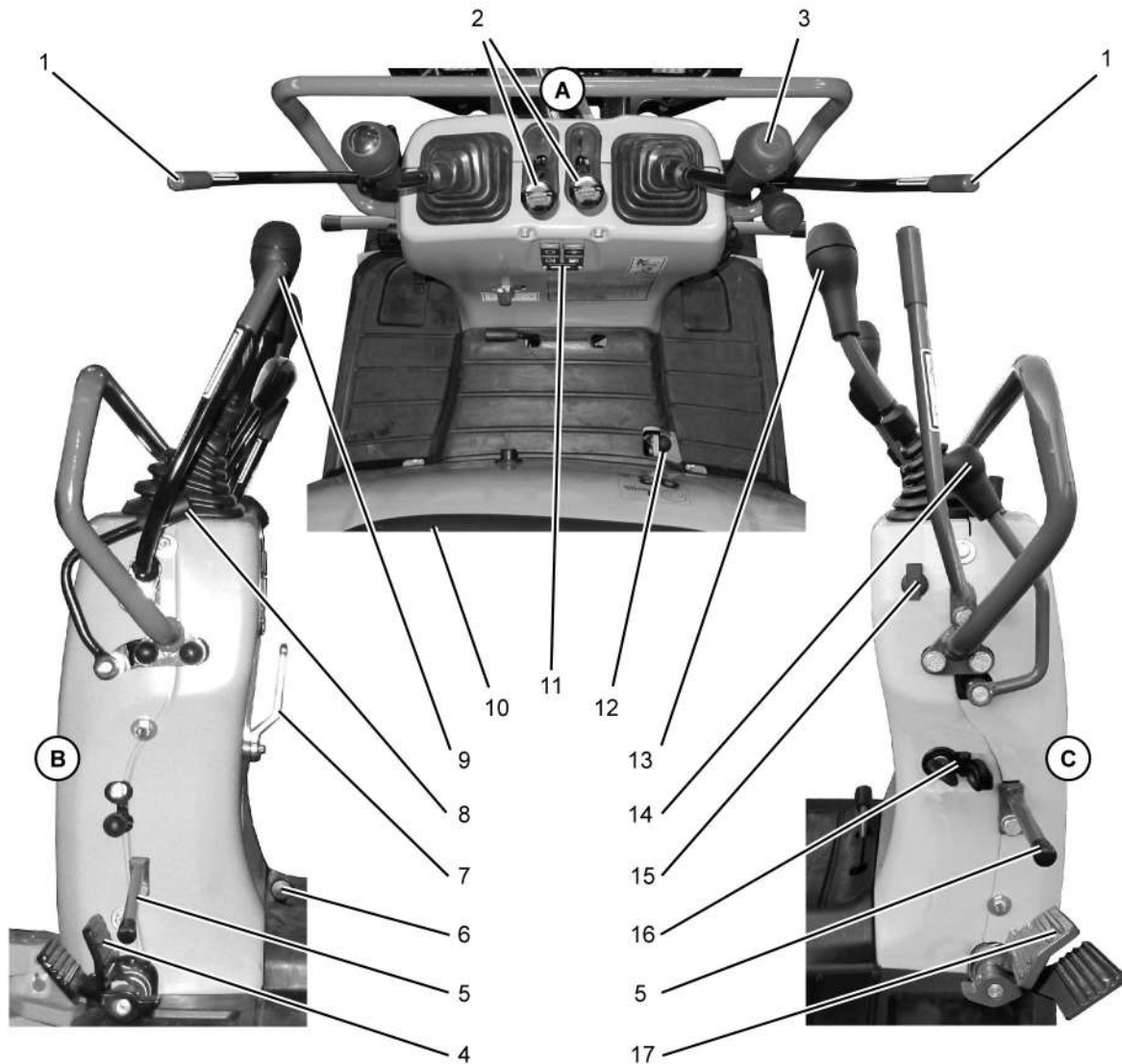

Illustration 53

g02462856

- (A) Top View
- (B) Left side view
- (C) Right side view
- (1) Hydraulic Lockout Control
- (2) Drive Lever
- (3) Horn
- (4) Auxiliary Control Pedal
- (5) Footrest

- (6) Adjustable Undercarriage Control and Dozer Blade Control Selection Lever
- (7) Work Tool Flow Mode Control
- (8) Throttle
- (9) Left control Lever
- (10) Seat
- (11) Indicator
- (12) Swing Lock Pin Control

- (13) Right Control Lever
- (14) Dozer Blade Control and Adjustable Gauge Undercarriage Control
- (15) Power Outlet (12V)
- (16) Engine Start Switch
- (17) Boom Swing Control

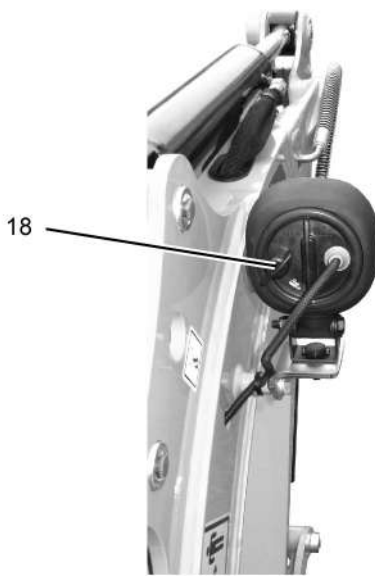

Illustration 54

g02463956

(18) Work Light Switch 300.9D

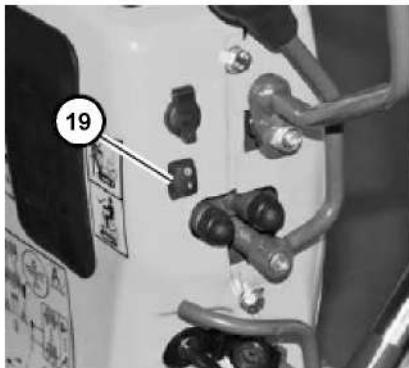

Illustration 55

g06100463

(19) LED Work Light Switch 300.9D VPS

Hydraulic Lockout Control(1)

WARNING

Deactivation of the controls and drive levers does not prevent the blade, boom swing, or auxiliary circuit functions from moving if the blade lever or a foot pedal is moved.

Personal injury or death may occur from sudden machine movement.



Locked – Place the hydraulic lockout control in the **RAISED** position to deactivate the hydraulic controls.

Make sure that the hydraulic lockout control is in the **RAISED** position before you exit the machine.

Note: Due to safety reasons, put the hydraulic lockout control in the **RAISED** position before starting the engine.



Unlocked – Place the hydraulic lockout control in the **LOWERED** position. When the hydraulic lockout control is in the **LOWERED** position, the controls and drive levers are operable.

Travel Controls (2)

Note: Normal steering occurs when the operator station is facing the blade. The travel lever information given below is for when the blade is in front of the operator station. Reverse steering occurs when the blade is behind the operator station. The directional functions and the steering will be reversed.

When you travel, make sure that the blade is in front of the operator station.

When the travel levers are moved in the forward direction, the machine will always travel toward the blade. When the travel levers are moved in the reverse direction, the machine will always travel away from the blade.

If you move a travel lever farther in the forward direction, the forward travel speed will increase. If you move a travel lever farther in a backward direction, the reverse travel speed will increase.

Move both of the travel levers equally in the same direction to travel in a straight line.

Note: In steep downhill operation, carefully operate the travel levers.

Right Travel Lever

Illustration 56

g02463816

REVERSE (2a) – Move the right travel lever backward to operate the right track in a reverse direction.

STOP (2b) – Release the right travel lever to stop the right track.

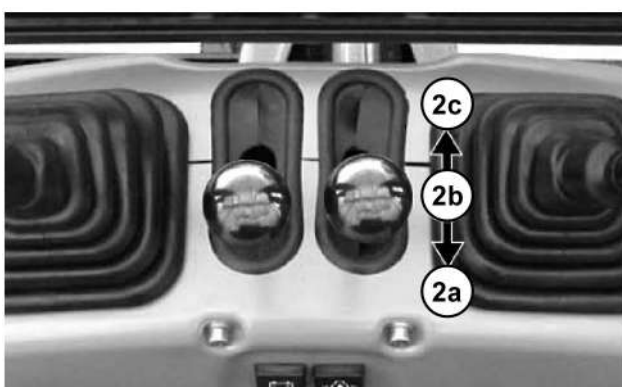
FORWARD (2c) – Move the right travel lever forward to operate the right track in a forward direction.

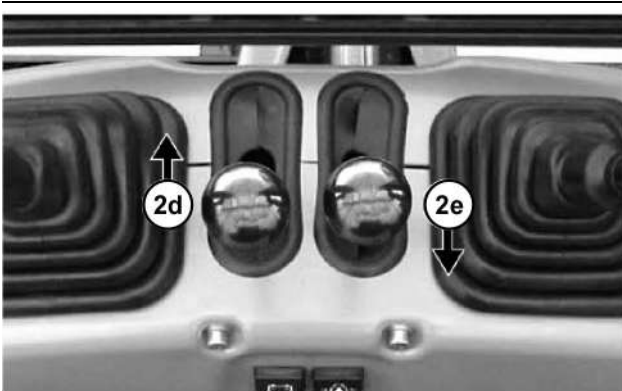

Illustration 57

g02463836

Spot Right Turn – Move the right travel lever (2e) backward. Move the left travel lever (2d) forward at the same time. This method will turn the machine quickly to the right.

Pivot Right Turn – Move the left travel lever (2e) forward. This method will turn the machine to the right.

Left Travel Lever

Illustration 58

g02463856

REVERSE (2a) – Move the left travel lever backward to operate the left track in a reverse direction.

STOP (2b) – Release the left travel lever to stop the left track.

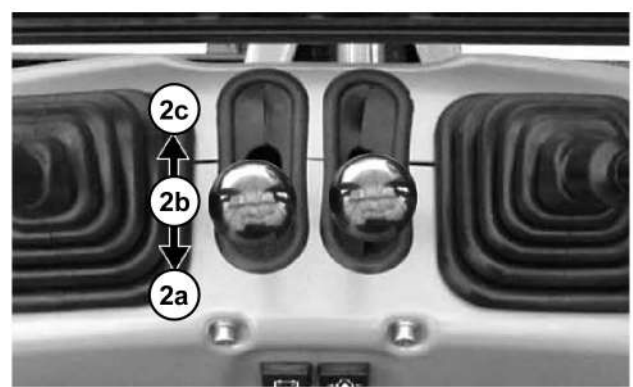
FORWARD (2c) – Move the left travel lever forward to operate the left track in a forward direction.

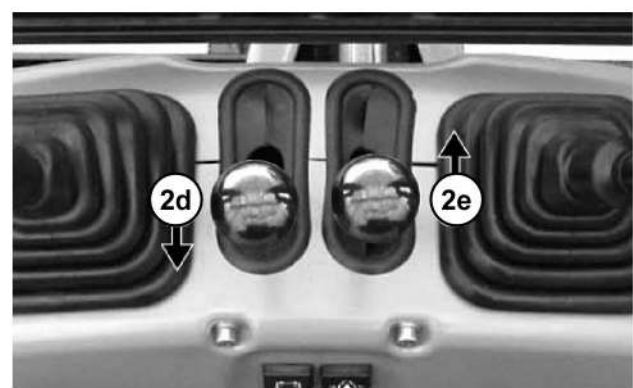

Illustration 59

g02463858

Spot Left Turn – Move the left travel lever (2d) backward. Move the right travel lever (2e) forward at the same time. This method will turn the machine quickly to the left.

Pivot Left Turn – Move the right travel lever (2e) forward. This method will turn the machine to the left.

Horn (3)



Horn (3) – The horn button is on the right side joystick. Depress the horn button to sound the horn. Use the horn before starting the engine, or for alerting or signaling personnel.

Auxiliary Control Pedal (4)

The auxiliary control pedal is used to control the work tools. For more information on the auxiliary controls, refer to Operation and Maintenance Manual, “Work Tool Control”.

Adjustable Undercarriage Control and Dozer Blade Control Selection Lever (6)

If equipped, the position of lever (6) determines which function lever (14) controls.

Note: Before operating the dozer blade control, refer to “Dozer Blade Control (14)”.

When lever (6) is rotated to the left and in the horizontal position, lever (14) will control the dozer blade functions.

When lever (6) is rotated to the right and in the vertical position, lever (14) will control the adjustable undercarriage functions.

Note: Before operating the adjustable undercarriage control, refer to this Operation and Maintenance Manual, “Adjustable Gauge Undercarriage Frame”.

Work Tool Flow Mode Control (7) (If Equipped)

If equipped with a two-way flow circuit, the work tool flow mode control valve is at the operator stand.

The auxiliary control pedal has different functions in one-way flow and in two-way flow. One-way flow is used when you operate work tools such as hammers. Two-way flow is used when you operate work tools such as grapples. Refer to Operation and Maintenance Manual, “Work Tool Control” for more information.

S/N: LJM1–Up

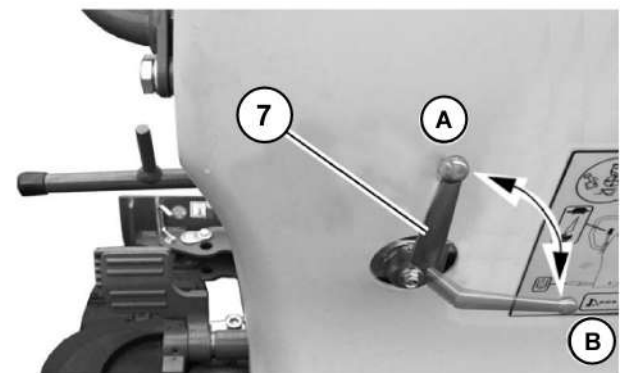

Illustration 60

g03566256



One-Way Flow (A) – Move lever (7) to this position when one-way flow is required.



Two-Way Flow (B) – Move lever (7) to this position when two-way flow is required.

S/N: LJM00722–Up; LJ21–Up

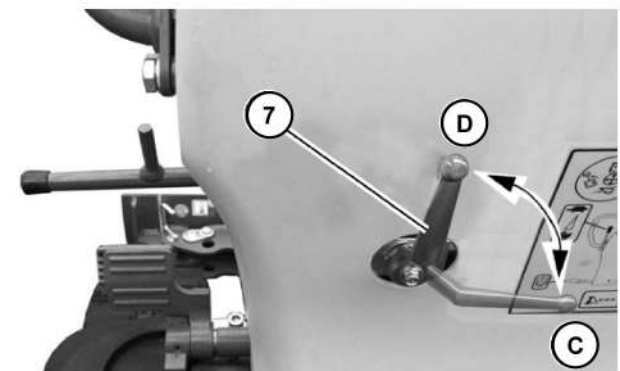

Illustration 61

g03566257



One-Way Flow (C) – Move lever (7) to this position when one-way flow is required.



Two-Way Flow (D) – Move lever (7) to this position when two-way flow is required.

Governor Control Lever (8)

After machine starting and machine warmup, select the desired engine speed with the governor control lever.

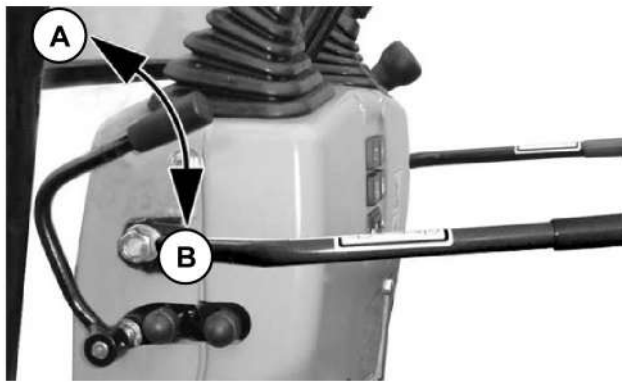

Illustration 62

g02463939

Low engine idle (A) – The engine operates in the low rpm range.

High engine idle (B) – The engine operates in the high rpm range.

Joystick Controls (9, 13)

The joystick controls are used to control the functions of the work tools. For more information on the individual functions of the joysticks, refer to Operation and Maintenance Manual, “Joystick Controls”.

Operators Seat (10)

The operators seat has various adjustments to meet a wide range of operators. For more information, refer to Operation and Maintenance Manual, “Seat”.

Monitoring System (11)

The machine alert indicators are located in the monitoring panel.

Refer to Operation and Maintenance Manual, “Monitoring System” for more information.

Swing Lock Pin Control (12)

WARNING

Visually check to ensure the swing lock pin has properly engaged the swing lock pin block to the lower structure, especially before lifting or transporting the machine.

If the pin is not properly engaged, the upper structure can swing and can result in personal injury.

NOTICE

Engage the pin only when the upper structure is aligned with the lower carriage structure.

Do not attempt to engage the pin when the upper structure is rotating. Machine damage can result.

Do not attempt to swing the upper structure when the pin is locked. Damage to the machine can result.

The swing lock pin control is on the right front side of the operator seat along the floor.



Pin Engaged – Align the upper structure so that the swing lock block is above the slot. Turn the lever and lower the lever.

The upper structure will not swing when the lever is down. Always engage the swing lock pin before traveling with the machine or shipping the machine.



Pin Disengaged – The upper structure can swing when the lever is up and when the lever is in the detent.

Dozer Blade Control (14)

Note: Before operating the dozer blade, make sure that lever (6) (if equipped) is rotated to the left and in the horizontal position.



Lower – Push lever (14) forward to lower the blade. The lever will return to the HOLD position when you release the lever. The blade will remain in the selected position.

Hold – Lever (14) will return to the HOLD position when the lever is released from the RAISED or LOWERED position.



Raise – Pull lever (14) backward to raise the blade. The lever will return to the HOLD position when you release the lever. The blade will remain in the selected position.

Adjustable Gauge Undercarriage Control (14)

Before operating the adjustable undercarriage control, refer to Operation and Maintenance Manual, “Adjustable Gauge Undercarriage Frame”.

Power Outlet (15)

A 12V power receptacle is on the right side console. This power receptacle can be used for powering automotive electrical equipment or accessories. Raise the cap before use.

Note: This receptacle can also be used for the service light.

Engine Start Switch (16)

NOTICE

For safety reasons, put the hydraulic lockout lever in the RAISED position when you are starting the engine.

0 OFF – Insert the engine start switch key only from the OFF position and remove the engine start switch key only from the OFF position. In the OFF position, there is no power to most electrical circuits.

Turn the engine start switch key to the OFF position to stop the engine.

I ON – Turn the engine start switch key to the ON position to energize all the electrical circuits. The fuel pump is on and the indicator lights illuminate.

II RUN – The engine start switch returns to this position once the engine has been started.

Note: Leave the engine start switch key in the RUN position for 15 seconds to heat the glow plugs. Attempt to start the engine.

III START – Turn the engine start switch key clockwise to the START position to crank the engine. Release the engine start switch key after the engine starts and the engine start switch key returns to the RUN position.

Note: If the engine fails to start, the engine start switch key must be returned to the OFF position to attempt to start the engine again.

Boom Swing Control (17)

⚠ WARNING

Unexpected operation of the boom swing control can cause injury or death.

A vertically folded boom swing control pedal does not mean that the boom swing function is locked out.

To prevent unexpected activation of the boom swing control while traveling or whenever the boom swing control is not being used, make sure that the boom swing control pedal is folded vertically.

The boom swing pedal is used to swing the boom to the right or to the left. The boom swing pedal is on the floor on the right side.

The boom swing control pedal is hinged and spring loaded. Operate the boom swing control pedal by folding the pedal down to the horizontal position.

Note: Remove your foot from the pedal when not in use and the pedal will automatically return to the vertical position.

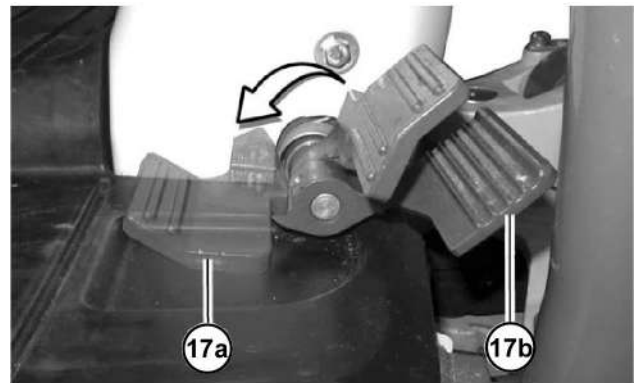

Illustration 63

g02463797



Swing Left (17a) – Push down on the front half of the boom swing pedal to swing the boom to the left.



Swing Right (17b) – Push down on the rear half of the boom swing pedal to swing the boom to the right.

Note: Operate the boom swing control pedal carefully until you become familiar with how boom swing reacts to the controls.

Work Light Switch (18) 300.9D

The switch for the work lights is on the rear of the work light. The light switch has two positions.



Lights – Turn the switch clockwise to turn on the work light that is on the boom. Turn the switch clockwise again to turn off the work lights.

LED Work Light (19) 300.9D VPS

The Dual Power option includes an energy-saving LED working light that is switched on and off with switch (19) on the right side console.

Beacon (If Equipped)

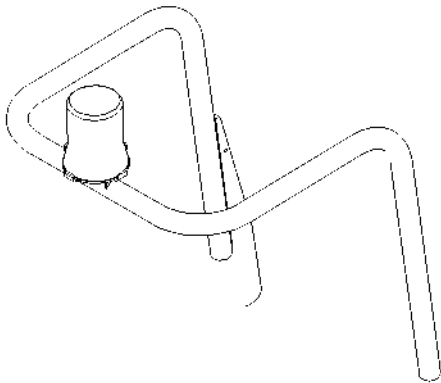

Illustration 64

g02463976

Insert the connector for the beacon into power outlet (15) to provide power for the beacon.

i06721863

Power Mode (Dual Power Mode)

SMCS Code: 7000

S/N: DW21–Up

S/N: TGP1–Up

Dual Power enables zero-emission working by means of an electro-hydraulic power pack or conventional working with the diesel engine.

NOTICE

To provide the best performance and to avoid damage to the machine, Caterpillar recommends operating the 300.9D VPS Mini Hydraulic Excavator in dual-power operation only with the HPU300 power pack.

NOTICE

Possible damage to the hydraulic system.

- Always couple and uncouple in the correct boom and dozer blade position.
- Before coupling or uncoupling hoses, stop the power pack and the engine of the excavator.

Note: Do not travel across flexible hydraulic lines or connecting cables.

Note: The hydraulic hoses of the power pack must be connected to the excavator before switching on the power pack.

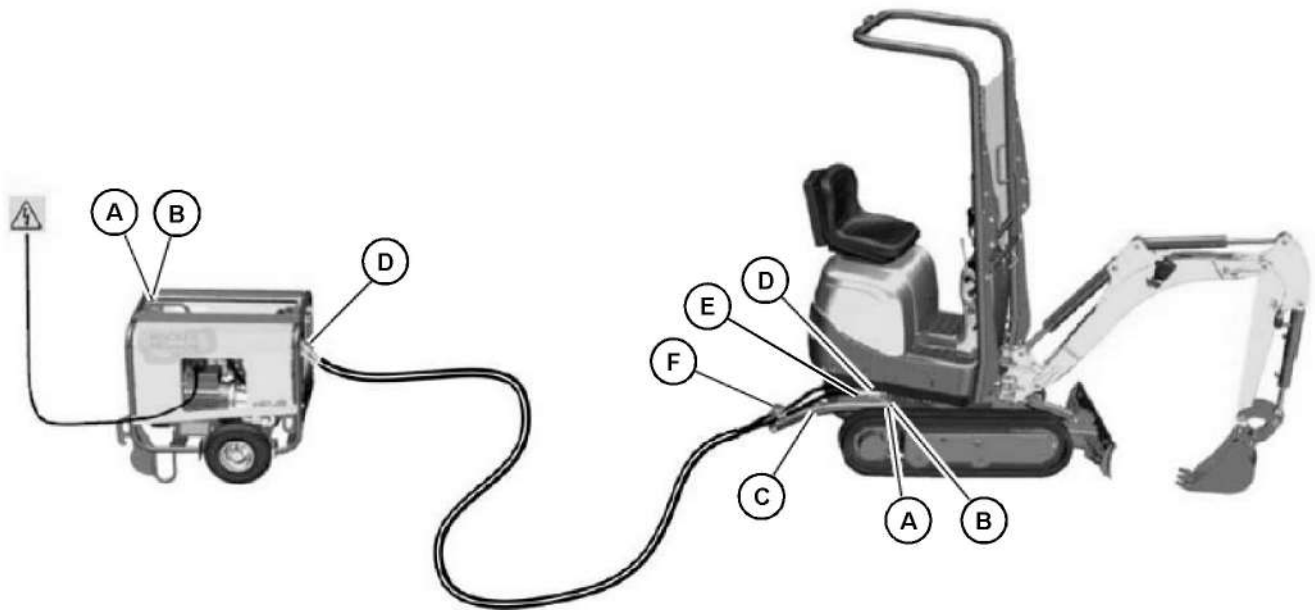

Illustration 65

g06091360

(A) Split Pin
(B) Pins(C) Lance
(D) Hydraulic Connection(E) Hydraulic Connection
(F) Clamping Screw

Coupling the 300.9D VPS * +Excavator to the Power Pack

1. Place the machine and the power pack at an open area, on flat, solid ground.

3. Swing the upper structure to position the dozer blade behind the operator and to allow access to the Power Pack-connection points on the lower structure.

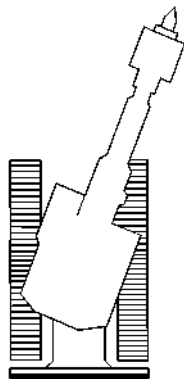

Illustration 66

g06100168

2. Position the upper structure as shown.

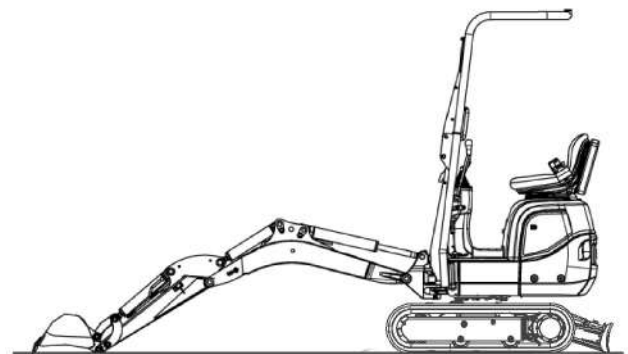

Illustration 67

g06100215

4. Lower the blade to the ground.

5. Extend the stick and the bucket fully. Lower the boom so that the bucket is rested on the ground.

6. Shut off the engine.

Operation Section
Dual Power Mode

7. Cycle the joysticks to relieve any pressure remaining in the hydraulic lines.
8. Move the hydraulic lockout control lever to the RAISED position.
9. Make sure that the Power Pack is switched off.

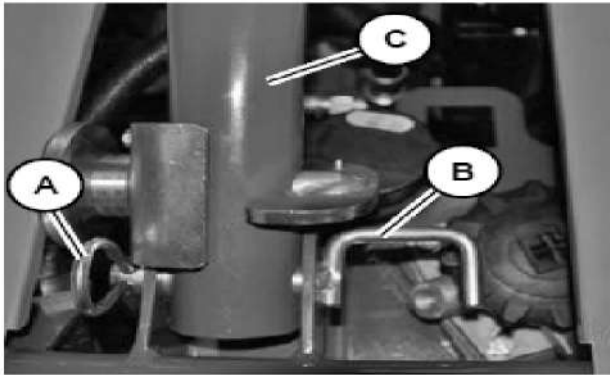

Illustration 68

g06091363

10. Pull out split pin (A) and pin (B) (at the front and rear) on the power pack and remove lance (C) from the power pack.
11. Install the pin and the split pin on the power pack again.

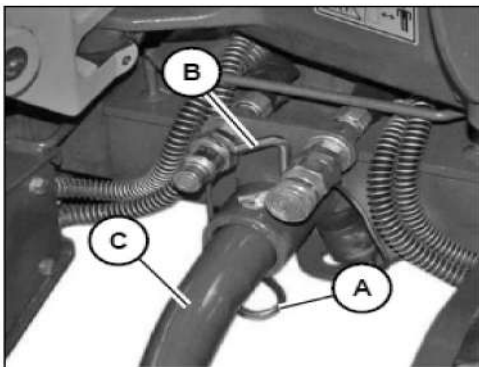

Illustration 69

g06091364

12. Insert lance (C) in the holder on the excavator and secure the lance with pin (B) and split pin (A).

NOTICE

Possible damage due to use of different hydraulic oil.

The power pack and excavator must be fitted with Cat HYDO Advanced 10 or equivalent. Operation is prohibited if other oil types/grades or biodegrade hydraulic oil is used.

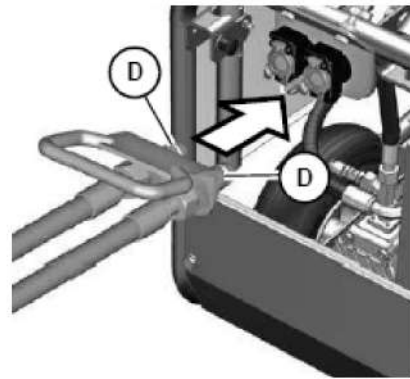

Illustration 70

g06091822

13. Connect the hydraulic hose connections (D) to the power pack.

Note: Use caution and wear protective gloves when making hydraulic hose connections.

Note: Use a suitable container and discard spilled oil according to local regulations.

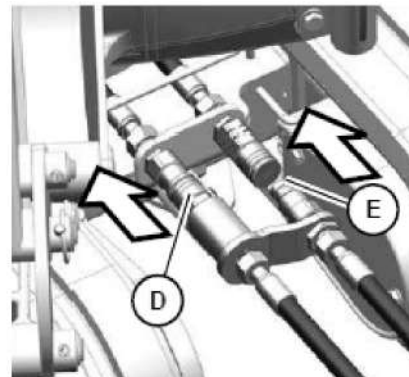

Illustration 71

g06091825

14. Connect the hydraulic hose connection (D) to the excavator.
15. Connect the hydraulic hose connection (E) to the excavator.



Illustration 72

g06091829

16. Tighten clamping screw (F) and fasten the hose on the lance as shown.

Checking the Hydraulic Oil Levels of the Excavator and the Power Pack

NOTICE

Possible damage to the power pack or excavator.

- Check the hydraulic oil levels before starting and observe the following measures.
- Do not start the engine of the excavator during power pack operation. Starting the engine will cause the hydraulic oil levels of the power pack and excavator to be exchanged.

Check the hydraulic oil levels before starting the power pack.

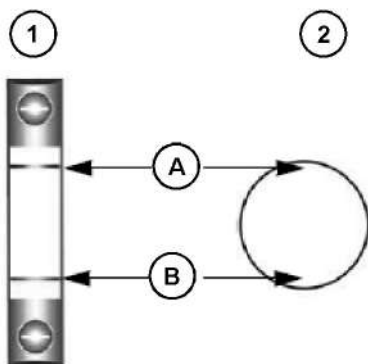

Illustration 73

g06091845

- (1) Hydraulic Power pack
- (2) Excavator
- (A) Maximum hydraulic oil level
- (B) Minimum hydraulic oil level

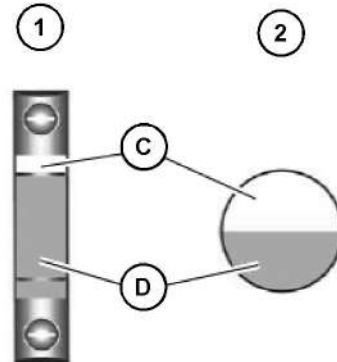

Illustration 74

g06091846

- (1) Hydraulic Power pack
- (2) Excavator
- (C) Air
- (D) Hydraulic oil

The Power Pack and excavator may only be put into operation if the hydraulic oil levels are between the minimum and maximum marks. Both hydraulic oil (D) and air (C) must be visible in the sight gauges.

Add hydraulic oil if no hydraulic oil can be seen in one of both sight gauges.

Do not start operation if no air can be seen in one of the sight gauges. Consult a Cat dealer.

Changeover from Hydraulic Power Pack (HPU) to Diesel Operation

NOTICE

Possible damage to the excavator if the engine is started in the HPU mode.

Stop the engine and change over from HPU to DIESEL operation.



Illustration 75

g02465536

The key for changing over between Hydraulic Power Pack and diesel operation is located in the seat back literature storage box.

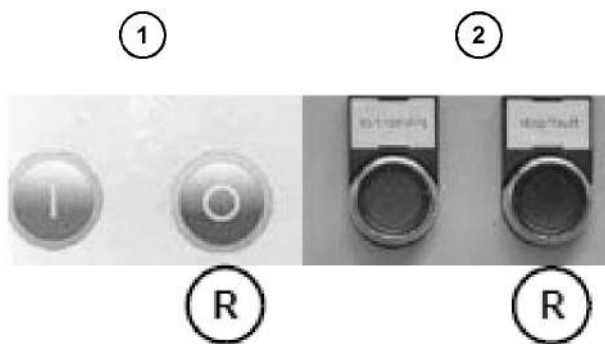

Illustration 76

g06092171

- (1) 7.5 kW (7500 watt) model
- (2) 9 kW (9000 watt) model
- (R) Stop button

1. Stop the HPU. Press the red stop button (R).

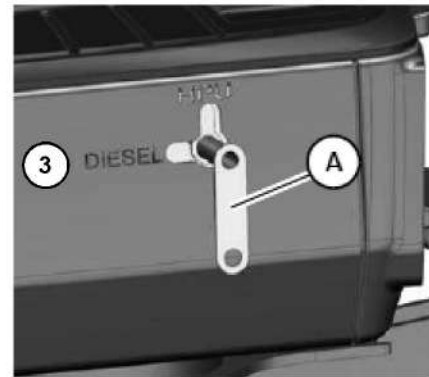

Illustration 77

g06092178

2. Insert key (A) and turn the key counterclockwise to position (3). Position 3 indicates "DIESEL" operation.

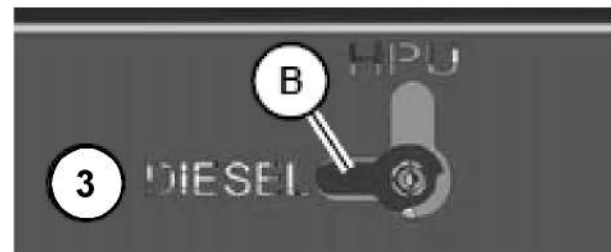

Illustration 78

g06092182

3. Indicator (B) must be in position (3).
4. Remove key (A) and store the key in the seat back literature storage box.

The engine can now be started.

Changeover from Diesel to Hydraulic Power Pack (HPU) Operation

The key for changing over between Hydraulic Power pack and diesel operation is located in the seat back literature storage box.

1. Shut off the engine.

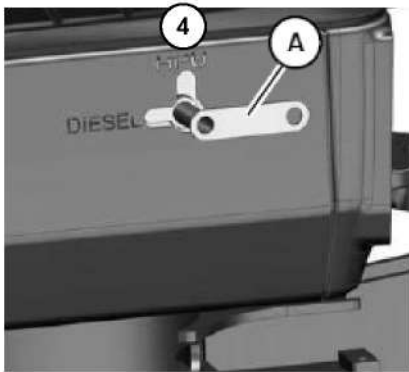

Illustration 79

g06092245

2. Insert key (A) and turn the key clockwise to position (4). Position 4 indicates "HPU" operation.

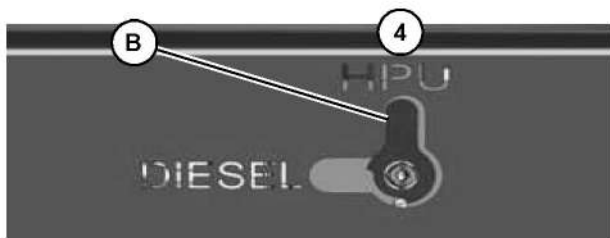

Illustration 80

g06092250

3. Indicator (B) must be in position (4).
4. Remove key (A) and store the key in the seat back literature storage box.

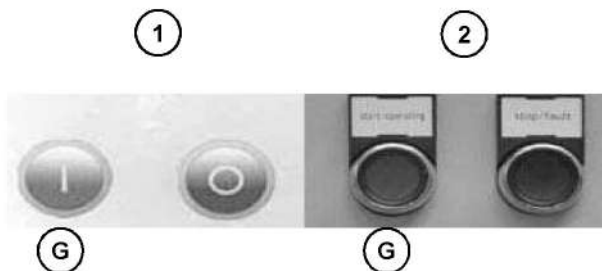

Illustration 81

g06092252

- (1) 7.5 kW (7500 watt) model
- (2) 9 kW (9000 watt) model
- (G) Start button

5. Switch on the HPU. Press the green start button (G).

Uncoupling

NOTICE

Possible damage to the hydraulic system.

- Always couple and uncouple in the correct boom and dozer blade position.
- Before coupling or uncoupling hoses, stop the power pack and the engine of the excavator.

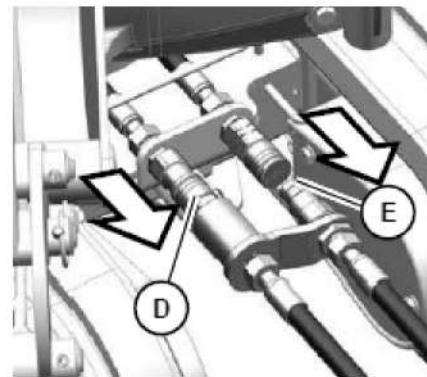

Illustration 82

g06092254

1. Uncouple the hydraulic hose connection (E) from the excavator.
2. Uncouple the hydraulic hose connection (D) from the excavator.

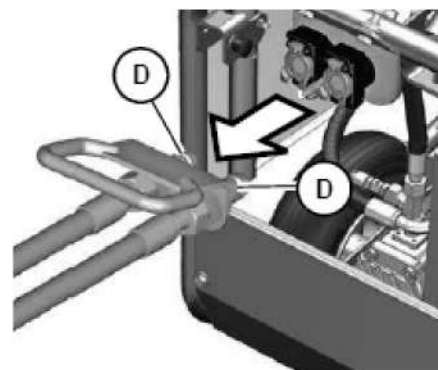

Illustration 83

g06092256

3. Uncouple the hydraulic hose connections (D) from the power pack.

Note: Use caution and wear protective gloves when disconnecting hydraulic hose connections.

Note: Use a suitable container and discard spilled oil according to local regulations.

Manually Charging the Excavator Battery

NOTICE

Possible damage to the power pack and excavator.

The power pack must be stopped during charging.

While running the excavator in HPU operation mode, the battery is not charged. Charging the battery regularly is therefore necessary.

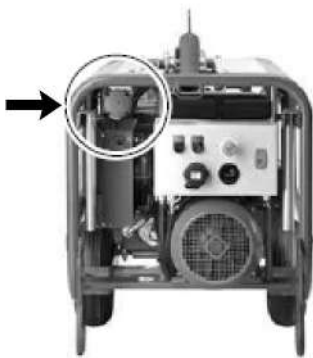

Illustration 84

g06092260

Note: Only operate battery chargers with the same specifications as the one supplied with the power pack. Observe the Operator Manual of the battery charger. Consult a Cat dealer for more information.

The battery charger is located in the storage compartment above the hydraulic-oil radiator of the power pack.

For more information, refer to the Operator Manual of the battery charger. The Operator Manual is located in the document box of the power pack.

The excavator battery can be charged in two different ways.

- With the power pack
- Directly with the 110 V / 230 V mains

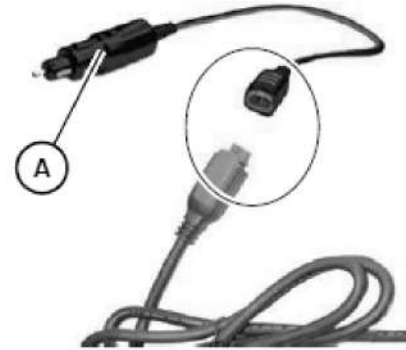

Illustration 85

g06092262

1. Connect connector (A) and bushing of the battery charger.

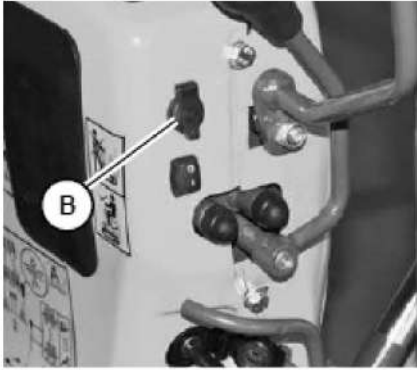

Illustration 86

g06092263

2. Connect the 12 V connector (A) to the 12 V outlet (B).

Charging the Battery with the Power pack

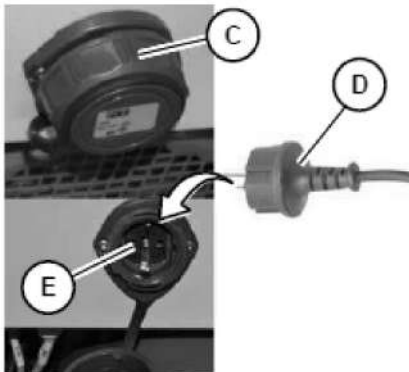

Illustration 87

g06092264

1. Turn protective cap (C) counterclockwise and remove the cap.

2. Connect connector (D) of the battery charger with the accessories outlet (E) of the power pack.

Charging the Battery with the Mains

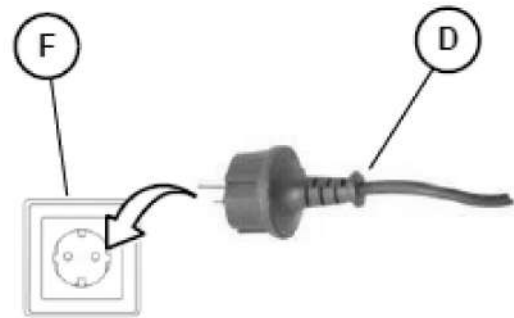

Illustration 88

g06092265

Connect connector (D) of the battery charger with outlet (F).

- Voltage for 7.5 kW version: 230 V
- Voltage for 9 kW version: 115 V

Operation with a Beacon in HPU Mode

The beacon must be supplied with external power in countries or regions where a beacon is mandatory during excavator operation.

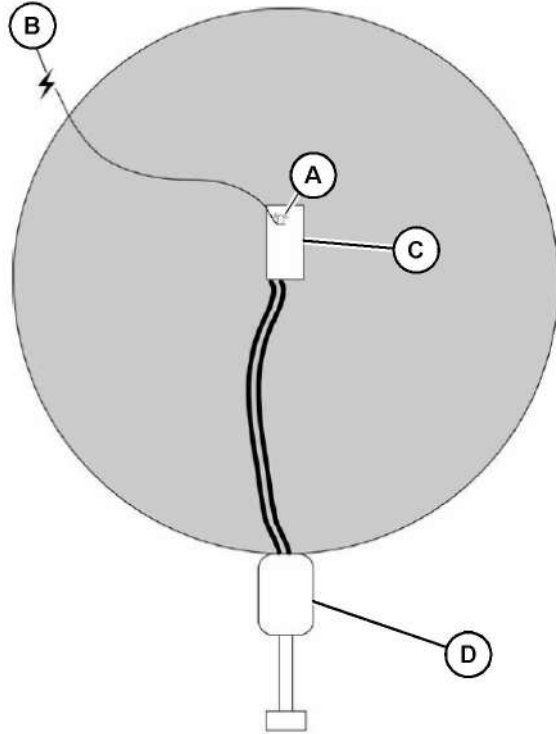

Illustration 89

g06092268

- (A) Beacon
(B) External Power Source
(C) Hydraulic Power pack
(D) Excavator

Connect beacon (A) to the external power supply (B). Connecting the beacon to the accessories outlet of the power pack is prohibited.

Note: Using a beacon screwed onto the power pack is prohibited. Caterpillar recommends a magnetic beacon.

i08001446

Product Link

SMCS Code: 7490; 7606

Note: Your machine may be equipped with the Cat® Product Link™ system.

The Cat Product Link communication device utilizes cellular and/or satellite technology to communicate equipment information. This information is communicated to Caterpillar, Cat dealers, and Caterpillar customers. The Cat Product Link communication device uses Global Positioning System (GPS) satellite receivers.

The capability of two-way communication between the equipment and a remote user is available with the Cat Product Link communication device. The remote user can be a dealer or a customer.

Data Broadcasts

Data concerning this machine, the condition of the machine, and the operation of the machine is being transmitted by Cat Product Link to Caterpillar and/or Cat dealers. The data is used to serve the customer better and to improve upon Cat products and services. The information transmitted may include: machine serial number, machine location, and operational data, including but not limited to: fault codes, emissions data, fuel usage, service meter hours, software, and hardware version numbers and installed attachments.

Caterpillar and/or Cat dealers may use this information for various purposes. Refer to the following list for possible uses:

- Providing services to the customer and/or the machine
- Checking or maintaining Cat Product Link equipment
- Monitoring the health of the machine or performance
- Helping maintain the machine and/or improve the efficiency of the machine
- Evaluating or improving Cat products and services
- Complying with legal requirements and valid court orders
- Performing market research
- Offering the customer new products and services

Caterpillar may share some or all the collected information with Caterpillar affiliated companies, dealers, and authorized representatives. Caterpillar will not sell or rent collected information to any other third party and will exercise reasonable efforts to keep the information secure. Caterpillar recognizes and respects customer privacy. For more information, please contact your local Cat dealer.

Operation in a Blast Site for Product Link Radios

WARNING

This equipment is equipped with a Cat® Product Link communication device. When electric detonators are being used for blasting operations, radio frequency devices can cause interference with electric detonators for blasting operations which can result in serious injury or death. The Product Link communication device should be deactivated within the distance mandated under all applicable national or local regulatory requirements. In the absence of any regulatory requirements Caterpillar recommends the end user perform their own risk assessment to determine safe operating distance.

Refer to your products Operation and Maintenance Manual Supplement, “Regulatory Compliance Information” for more information.

For information regarding the methods to disable the Cat Product Link communication device, please refer to your specific Cat Product Link manual listed below:

- Operation and Maintenance Manual, SEBU8142, “Product Link - PL121, PL321, PL522, and PL523”
- Operation and Maintenance Manual, SEBU8832, “Product Link PLE702, PLE602, PLE601, PL641, PL631, PL542, PL240, PL241, PL243, PL141, PL131, PL161, PL083 and PL042 Systems”

Note: If no radio disable switch is installed and the equipment will be operating near a blast zone, a Product Link radio disable switch may be installed on the equipment. The switch will allow the Cat Product Link communication device to be shut off by the operator from the equipment control panel. For more details and installation procedures, refer to the following:

- Special Instruction, REHS7339, “Installation Procedure for Product Link PLE640 Systems”
- Special Instruction, REHS8850, “Installation Procedure for the Elite Product Link PLE601, PLE641, and PLE631 Systems”
- Special Instruction, SEHS0377, “Installation Procedure for the Product Link PL131, PL141, and PL161 Systems”

- Special Instruction, REHS9111, “Installation Procedure for the Pro Product Link PL641 and PL631 Systems”
- Special Instruction, M0098124, “Installation Procedure for Pro Product Link PL243 Systems”
- Special Instruction, M0109130, “Installation Procedure for Product Link PL683 and PL783 Systems”

i06740131

Monitoring System

SMCS Code: 7451; 7490

The monitoring system alerts the operator of a problem or of an impending problem. The monitoring panel is designed to alert the operator of faulty machine systems.

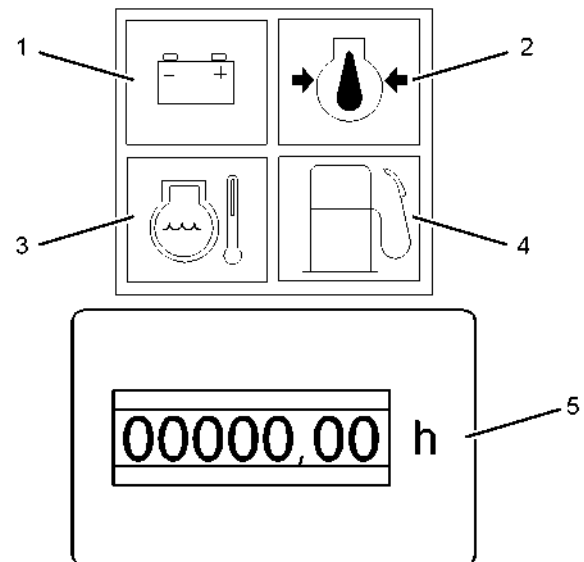

Illustration 90

g02465399

Alert Indicators



(1) Battery Charging – Indicator (1) will illuminate when there is a malfunction in the electrical system. If this alert indicator comes on, the system voltage is too high, or too low, for normal machine operation.

Note: Indicator (1) also illuminates when the engine start switch key is turned to the RUN position. The indicator goes off after the engine is started.

When the electrical load is high and the engine speed is near idle, increase the engine speed to high idle. Increasing the engine speed to high idle will generate more output from the alternator. If the alert indicator for the electrical system turns off within 1 minute, the electrical system is probably operating in a normal manner. However, the electrical system may be overloaded during periods of low engine speeds. When an overload occurs at low engine speed, one, or both, of the following actions should be performed:

- Increase the engine speed.
- Turn off any auxiliary electrical equipment.

If the alert indicator does not turn off, consult your Caterpillar dealer.



(2) Engine Oil Pressure – If the alert indicator illuminates, stop the engine immediately and check the engine oil level. If the engine oil level is at the correct level, consult your Cat dealer.

Note: Indicator (2) also illuminates when the engine start switch key is turned to the RUN position. The gauge goes off after the engine is started. In cold weather, indicator may remain on for more than 10 seconds after the engine is started.



(3) Engine Coolant Temperature – The alert indicator illuminates when the temperature of the engine coolant exceeds 110° C (230° F). If the alert indicator illuminates, stop the engine immediately and check the coolant level. Let the engine cool down before you start the engine again.



(4) Fuel System – The alert indicator will illuminate when the fuel level is too low to continue machine operations.

Service Hour Meter



(5) Service Hour Meter – This display indicates the total operating hours of the machine. Use the display to determine the service hour maintenance intervals.

i04301291

Storage and Literature Compartment

SMCS Code: 7268



Illustration 91

g02465536

The compartment at the back of the seat is used in order to store the literature for the machine.

i05604769

Window (Front) (If Equipped)

SMCS Code: 7310-FR

WARNING

When installing or removing the polycarbonate shield, be extra careful to prevent any personal injury. Also, the hydraulic lockout control must be in the RAISED position to prevent any possibility of sudden movement of the machine due to inadvertent contact with the hydraulic controls.

NOTICE

Remove the polycarbonate shield if the machine is transported on an open platform. The polycarbonate shield may become deformed, or detached from the machine due to increased air pressure.

Note: A polycarbonate shield can only be installed, if the machine is equipped with a roll bar (ROPS).

Do not install/remove the polycarbonate shield until the following items have been done:

- Park the machine on a level surface.
- Lower the work tools and the blade to the ground.
- Move the hydraulic lockout control to the RAISED position.
- Remove the engine start switch key.

Perform the following procedure in order to install the polycarbonate shield.



Illustration 92

g02465856

1. Slide polycarbonate shield (1) with the help of another person from above into the guides on the ROPS.
2. Secure the polycarbonate shield with pins (2).

Perform the following procedure in order to remove the polycarbonate shield.

1. Remove two pins (2).
2. Slide polycarbonate shield (1) with the help of another person upwards out of the grooves in the ROPS.

Note: Protect the polycarbonate shield from damage while in storage.

i04301330

Joystick Controls

SMCS Code: 5705

The machine control pattern is set at the factory to the SAE J1177 and ISO10968 pattern for an excavator.

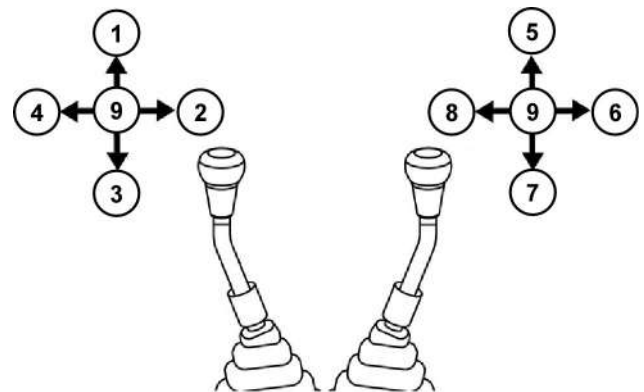

Illustration 93

g02465576



STICK OUT (1) – Move the left joystick to this position in order to move the stick outward.



Swing Right (2) – Move the left joystick to this position in order to swing the upper structure to the right.



STICK IN (3) – Move the left joystick to this position in order to move the stick inward.



Swing Left (4) – Move the left joystick to this position in order to swing the upper structure to the left.



BOOM LOWER (5) – Move the right joystick to this position in order to lower the boom.



BUCKET DUMP (6) – Move the right joystick to this position in order to dump the bucket or the work tool.



BOOM RAISE (7) – Move the right joystick to this position in order to raise the boom.



BUCKET CLOSE (8) – Move the right joystick to this position in order to close the bucket or the work tool.

HOLD (9) – When you release a joystick from any position, the joystick will return to the HOLD position. Movement of the structure will stop.

Two functions may be performed at the same time by moving the joysticks diagonally.

i07937296

Work Tool Control

SMCS Code: 6700

Auxiliary lines are equipped with coupler assemblies. Wipe all coupler assemblies before you connect the work tools. The auxiliary lines must be relieved of pressure to connect the coupler assemblies to the work tool. Relieve the pressure in the auxiliary hydraulic lines by performing the following steps:

1. Operate the machine to charge the accumulator.
2. Lower implements to the ground.
3. Turn off the engine and turn the key switch to the START position without starting the engine.
4. Ensure that the Hydraulic Lockout control is in the UNLOCKED position to provide function to the hydraulic circuits.
5. Actuate the auxiliary circuit in both directions several times.

Note: Pressure can build up in the auxiliary lines if the attachment is not coupled/uncoupled immediately after the pressure has been released.

WARNING

Unexpected operation of the auxiliary control circuit can cause injury or death.

A vertically folded auxiliary control pedal does not mean that the auxiliary control function is locked out.

In order to prevent unexpected operation of the auxiliary control circuit, make sure that the auxiliary control pedal is folded vertically while traveling. Also make sure that the auxiliary control pedal is folded vertically whenever the auxiliary lines are not being used.

Auxiliary Hydraulic Circuit

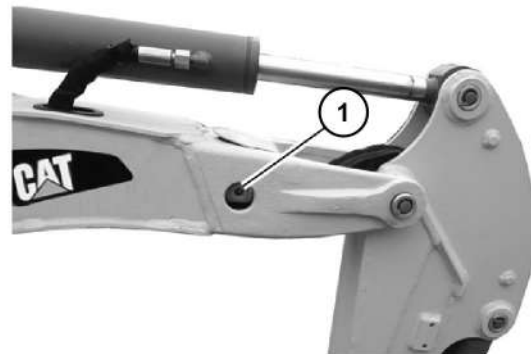

Illustration 94

g02465736

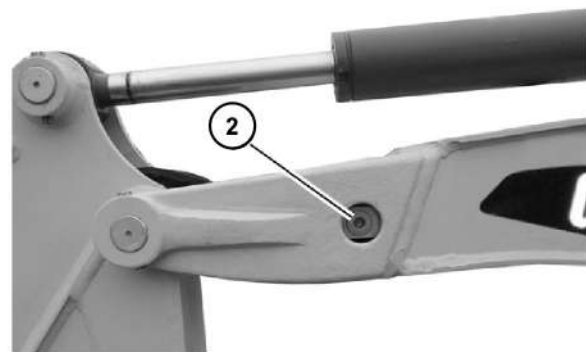

Illustration 95

g02465736

There are two auxiliary lines that are routed to the end of the boom.

Line (1) is located on the right side of the boom and is an oil feed line. Line (2) is located on the left side of the boom and is used as a return line.

The auxiliary lines can be equipped with hydraulic hoses and coupler assemblies. Wipe all coupler assemblies before you connect the work tools.

The auxiliary lines must be relieved of pressure in order to connect the coupler assemblies to the work tool. Relieve the pressure in the auxiliary hydraulic lines by performing the following steps:

1. Turn the engine start switch key to the OFF position.
2. Move the control levers in all directions repeatedly.
3. Uncouple the attachment immediately after the pressure has been released.

Note: Pressure can build up in the auxiliary lines if the attachment is not uncoupled immediately after the pressure has been released.

The hydraulic lines only provide one-way hydraulic flow. If the machine is equipped with a flow control valve, two-way hydraulic flow is possible. Refer to Operation and Maintenance Manual, "Operator Control - Work Tool Flow Mode Control".

Hydraulic Hoses and Coupler Assemblies (If Equipped)



Illustration 96

g02465836



Illustration 97

g02465838

There are two auxiliary lines that are routed to the stick. Line (3) is located on the right side of the stick and is as an oil feed line. Line (4) is located on the left side of the stick and is used as a return line.

The auxiliary lines can be equipped with coupler assemblies. Wipe all coupler assemblies before you connect the work tools. The auxiliary lines must be relieved of pressure in order to connect the coupler assemblies to the work tool. Relieve the pressure in the auxiliary hydraulic lines by performing the following steps:

1. Turn the engine start switch key to the OFF position.
2. Move the control levers in all directions repeatedly. The pressure in the sections that have been actuated will be released.

3. Uncouple the attachment immediately after the pressure has been released.

Note: Pressure can build up in the auxiliary lines if the attachment is not uncoupled immediately after the pressure has been released.

The hydraulic lines only provide one-way hydraulic flow. If the machine is equipped with a flow control valve, two-way hydraulic flow is possible. Refer to Operation and Maintenance Manual, "Operator Control - Work Tool Flow Mode Control".

Work Tool Pedal (One-Way Flow)

The left pedal controls the one-way flow circuit.

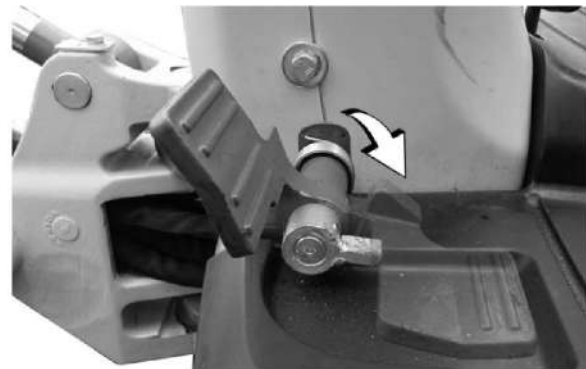

Illustration 98

g02466117

Fold the work tool pedal to the HORIZONTAL position.

The work tool pedal is hinged and spring loaded. Operate the work tool pedal by folding the pedal down to the HORIZONTAL position. The one-way flow circuit is now operable.

Remove your foot from the pedal when not in use and the pedal will automatically return to the VERTICAL position. The one-way flow circuit is now inoperable.

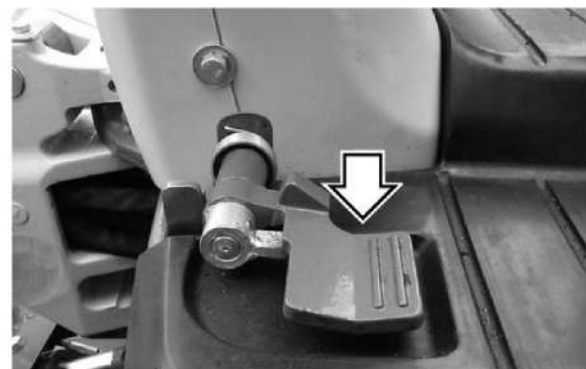

Illustration 99

g02466197

The work tool pedal is in the HORIZONTAL position and operable.

Operation Section

Joystick Controls Alternate Patterns

In order to pressurize the oil feed line, apply pressure to the pedal .

Hammer

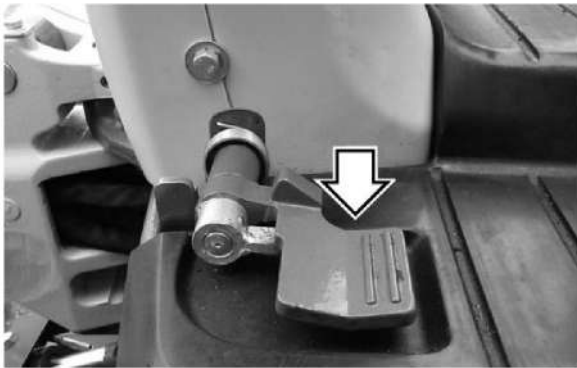

Illustration 100 g02466141

The work tool pedal is in the HORIZONTAL position. The hammer is operable.

Note: If equipped with a flow mode control valve, make sure that one-way flow is selected in order to operate a hammer.

Connect the hammer lines to the correct connectors.

Hammer ON – Apply pressure to the pedal in order to activate the hydraulic hammer.

Hammer OFF – Release the pedal in order to deactivate the hydraulic hammer.

Work Tool Pedal (Two-Way Flow)

The left work tool pedal controls the two-way flow circuit (if equipped).

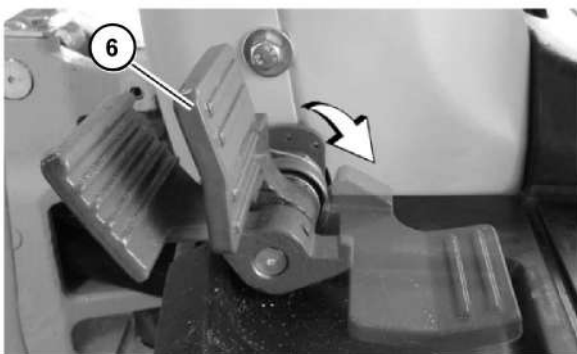

Illustration 101 g02466138

Fold the work tool pedal to the HORIZONTAL position.

The work tool pedal for two-way flow (6) is hinged and spring loaded. Operate the work tool pedal by folding the rear half of the pedal down to the HORIZONTAL position. The two-way flow circuit is now operable.

Remove your foot from the pedal when not in use and the pedal will automatically return to the VERTICAL position. The two-way flow circuit is now inoperable.

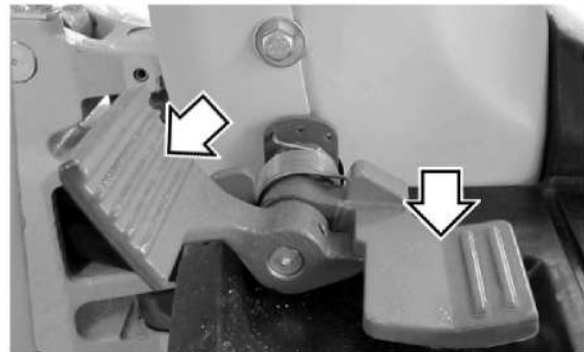

Illustration 102 g02466161

The work tool pedal is in the HORIZONTAL position and operable.

In order to pressurize the line that is connected to the left-hand side of the stick, apply pressure to the rear half of the pedal.

In order to pressurize the line that is connected to the right-hand side of the stick, apply pressure to the front half of the pedal.

i04935335

Joystick Controls Alternate Patterns

SMCS Code: 5059; 5137

WARNING

Check if control pattern 1 (Standard) or control pattern 2 (Alternate) is selected before operating the machine.

Refer to Operation and Maintenance Manual.

Failure to understand control functions could result in injury or death.

Joystick Control Selector (If Equipped)

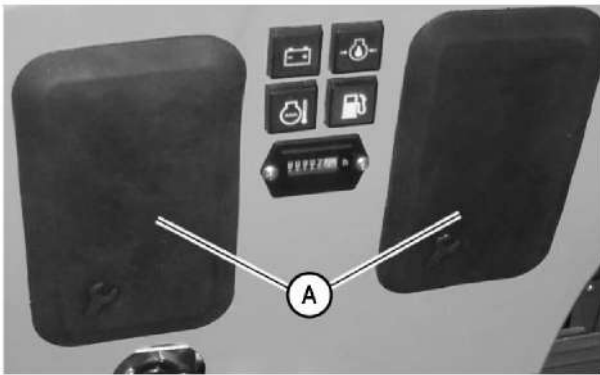

Illustration 103

g03109577

On machines which are equipped with a pattern changer, the operator stand has two covers (A) which give access to the patter changer.

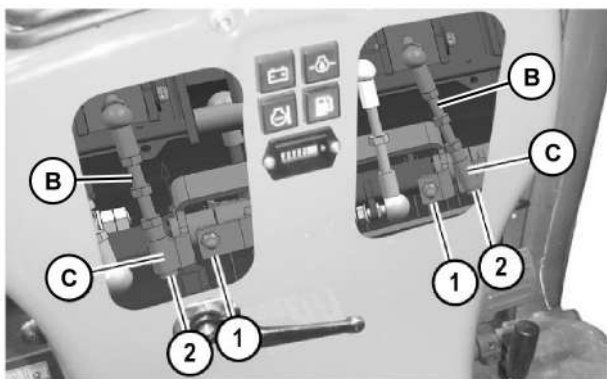

Illustration 104

g03109584

The machine may be equipped with a joystick control selector. The machine control pattern can be varied by switching the position of the rod linkage (B). Position (1) is the factory setting. This is the standard position. Position (2) is the alternate position. The alternate position allows the operator to change the functions of the joysticks.

1. Flip cover (A) upwards.
2. Push the self retaining bushing (C) on the rod linkage (B) upwards, in order to release the ball seat from the ball stud.
3. Keep the self retaining bushing pushed upwards and move rod linkage (B) to either ball stud (1) or ball stud (2) and mount the ball seat to the ball stud.
4. Release the self retaining bushing and make sure that the ball seat is locked with the ball stud.

5. Put the cover (A) back in place.
6. Flip the second cover (A) upwards and repeat step 2 to 5.

Alternate Joystick Control Pattern

The machine control pattern is set at the factory to the "SAE J1177" and "ISO10968" pattern for an excavator.

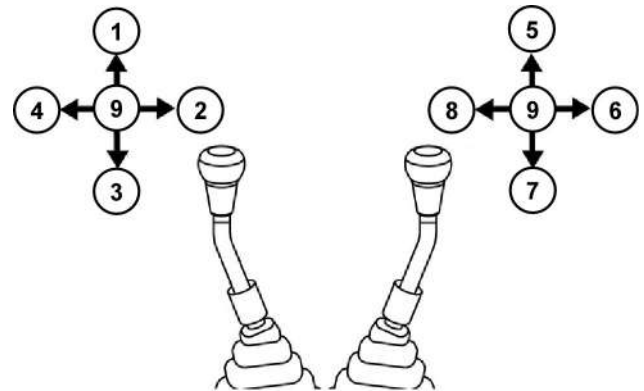

Illustration 105

g02465576



BOOM LOWER (1) – Move the joystick to this position in order to lower the boom.



SWING RIGHT (2) – Move the joystick to this position in order to swing the upper structure to the right.



BOOM RAISE (3) – Move the joystick to this position in order to raise the boom.



SWING LEFT (4) – Move the joystick to this position in order to swing the upper structure to the left.



STICK OUT (5) – Move the joystick to this position in order to move the stick outward.



BUCKET DUMP (6) – Move the joystick to this position in order to dump the bucket or the work tool.



STICK IN (7) – Move the joystick to this position in order to move the stick inward.



BUCKET CLOSE (8) – Move the joystick to this position in order to close the bucket or the work tool.

HOLD (9) – When you release the joystick from any position, the joystick will return to the HOLD position. Movement of the structure will stop.

Operation Section
Joystick Controls Alternate Patterns

Two functions may be performed at the same time by moving the joysticks diagonally.

Engine Starting

i07548967

Engine Starting

SMCS Code: 1000; 1090; 1456; 7000

WARNING

Do not use aerosol types of starting aids such as ether. Such use could result in an explosion and personal injury.

WARNING

Do not hold the engine start switch in the GLOW PLUG "II" position for longer than 20 seconds. Holding the engine start switch in this position can damage glow plugs and other engine components.

1. Move all hydraulic controls to the HOLD position or to the NEUTRAL position.
 2. Move the hydraulic lockout control to the RAISED position.
- Note:** The engine will not start unless the hydraulic lockout control is in the RAISED position.
3. Move the governor control lever to the low idle position before you start the engine.
 4. Before you start the engine, check for the presence of bystanders or maintenance personnel. Ensure that all personnel are clear of the machine. Briefly sound the horn before you start the engine.
 5. If the engine is cold, turn the engine start switch key to the GLOW PLUG "II" position. Hold the key in this position for 20 seconds and then start the engine by turning the key to the START "III" position.

NOTICE

Do not crank the engine for more than 10 seconds. If the engine does not start, allow the starter to cool for 2 minutes before cranking again. The engine start switch must be turned to the OFF position before trying to restart.

6. When the engine starts, release the engine start switch key.
7. If the engine does not start, release the engine start switch key and allow the starter to cool. Then, repeat Steps 5 through Step 6.

8. After the engine starts, leave the engine in low idle for at least 20 to 30 seconds. If the engine is cold, refer to Operation and Maintenance Manual, "Engine and Machine Warm-Up".

i04316864

Engine and Machine Warm-Up

SMCS Code: 1000; 7000

NOTICE

Keep the engine speed low until the engine oil pressure registers on the gauge or until the engine oil indicator light goes out.

If it does not register or the light does not go out within ten seconds, stop the engine and investigate the cause before starting again. Failure to do so, can cause engine damage.

Note: The hydraulic lockout control must be in the LOWERED position before the hydraulic controls will function.

1. Allow the engine to warm up at low idle for 5 minutes. Engage the joysticks for the work tool control and disengage the joysticks for the work tool control. This method will speed up the warm-up of the hydraulic components. If the temperature is cold or if hydraulic functions are sluggish, additional time may be required.
2. To warm up the hydraulic oil, turn the engine speed dial to the medium engine speed. Run the engine for approximately 5 minutes and move the joystick intermittently from the BUCKET DUMP position to the HOLD position. Do not hold the joystick in the BUCKET DUMP position with the bucket cylinder fully extended for more than 10 seconds.
3. Move the governor control lever to the maximum engine speed. Repeat Step 2.
This allows the oil to attain relief pressure, which causes the oil to warm up more rapidly.
4. Cycle all controls in order to circulate warm oil through all hydraulic cylinders and through all hydraulic lines.

 **WARNING**

When you cycle the machine controls, the machine can move suddenly. Contact between the machine and external objects or ground personnel can result in serious injury or death. Before you cycle the machine controls, the machine should be located in an unobstructed, hazard-free work area that is away from external objects and ground personnel.

5. Observe the gauges and the indicators frequently during the operation.

Operation

i04278055

Operation Information

SMCS Code: 7000

Make sure that no personnel are on the machine or near the machine in order to prevent any personal injury. Keep the machine under control at all times in order to prevent injury.

If the boom is in the raised position and if the engine is stopped, refer to Operation and Maintenance Manual, "Equipment Lowering with Engine Stopped" for the procedure to lower the boom.

Reduce the engine speed when you maneuver the machine in tight quarters and when you drive over an incline.

Select the necessary travel speed range before you drive downgrade. Do not change the speed range while you drive downhill.

Use the same travel speed on a downgrade and on an upgrade.

When you travel for any distance, keep the stick inward and carry the boom in a low position. A machine that is equipped with a blade should travel with the blade in the highest position.

When you travel on a steep grade, keep the work tool as close to the ground as possible on the downhill side of the machine.

When you travel on moderate uphill grades, keep the boom on the uphill side of the machine.

Operating Procedure

1. Adjust the operator seat.
2. Fasten the seat belt.
3. Start the machine and refer to Operation and Maintenance Manual, "Engine and Machine Warm-Up" for information about warming the engine and warming the hydraulic oil.
4. Raise the boom enough in order to provide sufficient ground clearance.
5. Make sure that the position of the upper structure and of the undercarriage is known before you move the machine. The dozer blade should be in front of the machine.

Note: The travel levers will operate normally if the dozer blade is in front of the machine. The travel levers will operate backward if the dozer blade is behind the machine.

6. Rotate the engine speed dial clockwise in order to increase the engine speed to the desired speed.
7. Push both travel levers forward at the same time in order to travel forward. If both travel levers are pushed farther, the travel speed at the selected engine speed will be faster.

Note: If the machine does not operate or if the machine does not travel in a straight line, consult your Caterpillar dealer.

8. See Operation and Maintenance Manual, "Operator Controls" for information on "Travel Control". This instruction is about spot turning and about pivot turns.
9. When you make turns in soft material, travel in a forward direction occasionally in order to clear the tracks.
10. Slowly move both of the travel levers to the center position in order to stop the machine.

i02365199

Frozen Ground Conditions

SMCS Code: 7000

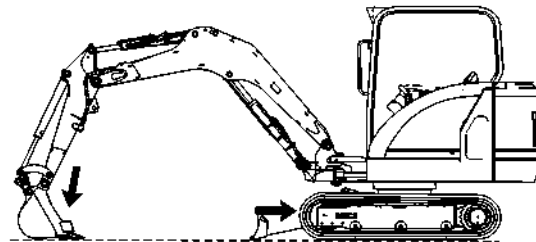

Illustration 106

g01181354

To free the tracks from frozen ground, swing the boom to the front of the machine. Use boom down pressure to free the idler end of the machine.

Swing the boom to the rear of the machine. Use boom down pressure to free the sprocket end of the machine.

i04285525

Equipment Lowering with Engine Stopped

SMCS Code: 7000

 **WARNING**

Personal injury or death can result from boom lowering.

The boom can drop when lowering it with the engine stopped.

Keep all personnel away from the boom drop area when lowering the boom with the engine stopped.

Be sure no one is under or near the front linkage before manually lowering the boom.

1. Move the hydraulic lockout lever to the LOWERED position.
2. Slowly, move the boom control lever to the BOOM LOWER position in order to lower the boom slowly.

Operating Techniques

i04302417

Operating Technique Information

SMCS Code: 7000

WARNING

Know the maximum height and reach of your machine. Serious injury or death by electrocution can occur if machine, work tools, or attachments are not kept a safe distance from electrical power lines. Keep distance at least 3 m (10 ft) Plus additional 10 mm (.4 inch) for each 1,000 volts over 50,000 volts.

For safety, the local codes, the state codes, or the requirements of the job site may require a greater distance.

NOTICE

When swinging into a ditch, do not use the ditch to stop the swinging motion. Inspect the machine for damage if the boom is swung into a bank or an object.

Repeated stopping by an object can cause structural damage if the boom is swung into a bank or an object.

Always swing as slowly as possible. Sudden swing start/stop motion can cause machine instability.

With certain work tool combinations, the work tool can hit the cab or the front of the machine. Always check for interference when first operating a new work tool.

Whenever the tracks of the machine raise off the ground while digging, lower the machine back to the ground smoothly. Do not drop or catch the machine with the hydraulics. Damage to the machine can result.

Do not move hydraulic cylinders to the end of the stroke. This could cause structural damage to the cylinders.

When digging, do not allow the stick cylinder or the bucket cylinder to contact the edge of the excavation.

Do not dig or excavate while the machine is traveling. This could cause damage to the work tool or to the machine.

Do not use the bucket as a pile driver or a hydraulic hammer.

With certain combinations of work tools, the auxiliary hydraulic pedal can have different functions. Always check the function of the auxiliary hydraulic pedal before you use the pedal.

Know the location of any buried cables. Mark the locations clearly before you dig.

Consult your Caterpillar dealer for special bucket tips that are available for use in severe applications.

Move the machine whenever the position for digging is not efficient. The machine can be moved forward or backward at any time during the operating cycle.

When you perform work in close places, utilize the bucket or other work tools in order to perform the following functions:

- Pushing the machine
- Pulling the machine
- Lifting the tracks

Use consistent, comfortable speeds while you operate the machine.

For efficient operation, use more than one control at a time, when possible.

Never swing the bucket or a load over a truck cab or any personnel.

Position a truck so that the machine can load material into the truck from the rear or from the side. Load the truck evenly so that the rear axles are not overloaded.

Do not use oversize buckets or oversize work tools as this could make the machine unstable.

The polycarbonate shield must be installed when a work tool that may create flying objects is used. Always remember to wear your safety glasses even when the polycarbonate shield is in place. Consult your work tool Operation and Maintenance Manual in order to determine if using a work tool will require the polycarbonate shield.

Digging

1. Lower the blade to the ground in order to ensure better machine stability while you are digging.
2. Position the stick at a 90 degree angle to the boom.
3. Position the bucket cutting edge at a 120 degree angle to the ground. Maximum breakout force can now be exerted with the bucket.

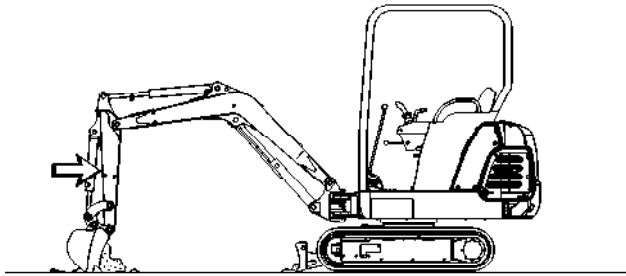

Illustration 107

g00394783

4. Move the stick toward the cab and keep the bucket parallel to the ground.
5. If the stick stops due to the load, raise the boom and/or perform a curl in order to adjust the depth of the cut.
6. To apply the greatest force at the cutting edge, decrease the down pressure as you move the stick toward the cab.
7. Maintain a bucket attitude that ensures a continuous flow of material into the bucket.
8. Continue the pass in a horizontal direction so that material peels into the bucket.

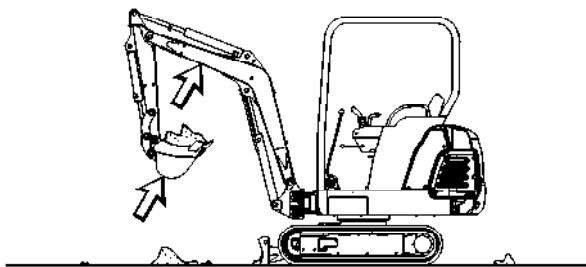

Illustration 108

g00394917

9. Close the bucket and raise the boom when the pass has been completed.
10. Engage the swing control when the bucket is clear of the excavation.

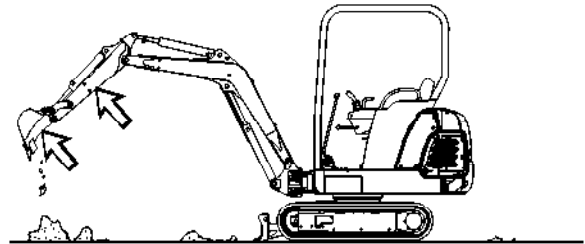

Illustration 109

g00394937

11. To dump a load, move the stick outward and open the bucket in a smooth motion.

Lifting Objects

WARNING

Lifting objects with this machine is **NOT ALLOWED**. Lifting with this machine may result in machine damage, personal injury, or death.

i04302418

Travel in Water and Mud

SMCS Code: 7000-V6

NOTICE

When working in or around any body of water, around a stream or river, or in conditions of heavy mud, be careful that the swing bearing, the swing drive gear, and the swivel joint do not dip into water, mud, sand, or gravel. If the swing bearing dips into water, mud, sand, or gravel, immediately grease the swing bearing until the used grease leaks from the outer circle of the swing bearing. Failure to carry out this procedure may cause premature wear in the swing bearing.

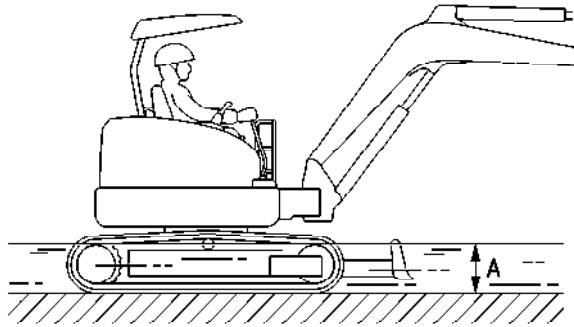

Illustration 110

g00818869

Maximum depth of water to the top edge of the idler wheel.

The following guidelines pertain to travel across water and through mud, sand, or gravel.

The machine can travel across a river only under the following conditions:

- The bed of the river is flat.
- The flow of the river is slow.
- The machine dips into the water only to the center of the track carrier roller (dimension A).

While you cross the river, carefully confirm the depth of the water with the bucket. Do not move the machine into an area that has a water depth that is greater than Dimension A.

The machine may sink gradually on soft ground. Therefore, frequently check the height of the undercarriage from ground level and the depth of water on the ground.

If you have any doubts that the water might have been too deep, contact your Cat dealer for the required check.

After you travel through water, carefully clean the machine in order to remove any salt, sand, or other foreign matter.

Procedure for Removing the Machine from Water or Mud

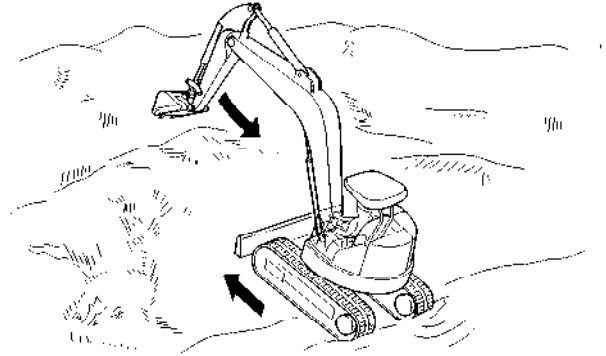

Illustration 111

g00818886

1. You may not be able to move the machine by using the travel controls only. In this case use both the travel control levers/pedals and the stick to pull the machine out of the water or ground.

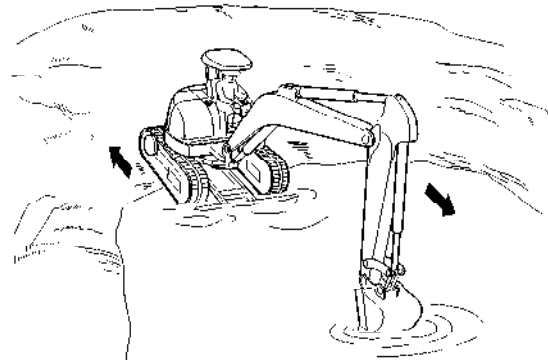

Illustration 112

g00818890

2. The machine may slip because of a steep slope. The procedure in Step 1 may not work. In this case, first rotate the upper structure by 180°. Then use both the travel control levers/pedals and the stick to move the machine up the slope.

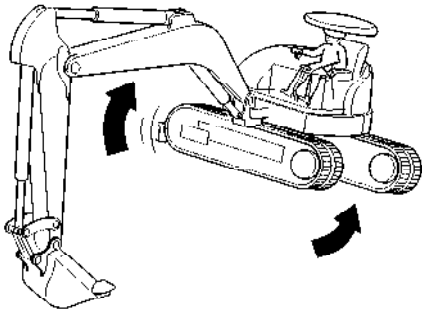

Illustration 113

g00818893

3. It may be impossible to travel because the bottom of the frame comes into contact with the ground or the undercarriage is clogged with mud or gravel. In this case, operate the boom and the stick together. Raise the track and rotate the track forward and backward in order to remove the mud and the gravel.

i04420313

Bucket - Remove and Install

SMCS Code: 6001-011; 6001-012; 6001; 6101; 6102; 6523

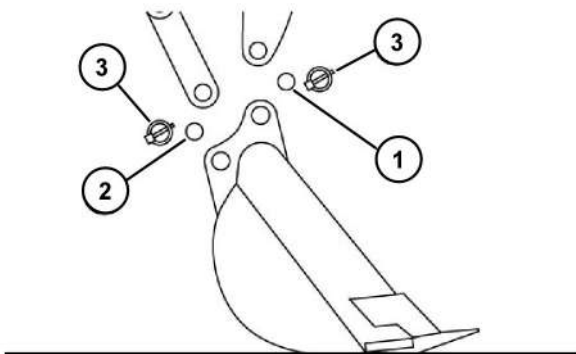

Illustration 114

g02466698

- (1) Pin
(2) Pin
(3) Locking Pin

Removal Procedure

⚠ WARNING

Driving in linkage pins with a hammer can cause the pins to splinter, which can cause severe personal injury.

Always use personal protective equipment (protective goggles, helmets, gloves, and other protective equipment) when installing linkage pins.

⚠ WARNING

When the pin assembly is removed, the linkage assembly may swing out of the bucket. To prevent possible personal injury, do not stand in front of, or do not stand behind the linkage assembly when the pin assembly is being removed. Do not place any part of the body (hands, feet, etc.) beneath the bucket.

1. Start the engine. Park the machine on a hard, level surface and lower the bucket to the ground. Shut off the engine.

Note: Make sure that the bottom side of the bucket is facing downward.

2. Remove locking pin (3) from support pin (2) and remove the pin that connects the connecting link to the bucket.
3. Remove locking pin (3) from support pin (1) and remove the pin that connects the stick to the bucket.
4. Start the engine and raise the stick out of the bucket.

Note: After the support pins have been removed, make sure that the support pins do not become contaminated with sand or dirt. Make sure that the stick and the linkage do not become damaged.

Installation Procedure

WARNING

Failure to follow the instruction below for the installation of a work tool may result in personal injury or death. Special care must be taken if more than one person is installing the work tool.

- Confirm the verbal communication and the hand signals that will be used during the installation.
- Be alert for sudden movement of the front linkage and the work tool.
- Do not insert fingers into the bores of the support pins when the support pins and the bores are being aligned.

WARNING

Driving in linkage pins with a hammer can cause the pins to splinter, which can cause severe personal injury.

Always use personal protective equipment (protective goggles, helmets, gloves, and other protective equipment) when installing linkage pins.

WARNING

When the pin assembly is removed, the linkage assembly may swing out of the bucket. To prevent possible personal injury, do not stand in front of, or do not stand behind the linkage assembly when the pin assembly is being removed. Do not place any part of the body (hands, feet, etc.) beneath the bucket.

1. Start the engine. Park the machine on a hard, level surface. Position the bucket on a hard, level surface with the bottom side facing downward.
2. Clean each pin and each pin bore. Lubricate each pin bore with molybdenum grease.
3. Start the engine and lower the stick into the bucket until the pin bores are in alignment with each other. Stop the engine and put the hydraulic lockout control in the RAISED position.
4. Install support pin (1) in order to connect the stick to the bucket. Secure the pin with locking pin (3).

5. Install support pin (2) in order to connect the connecting link to the bucket. Secure the pin with locking pin (3).
6. In order to verify a proper work tool installation, perform the following procedure:
 - a. Start the engine. Position the work tool on the ground.
 - b. Apply a slight down pressure on the work tool.
 - c. Retract and extend the stick cylinder in order to push the work tool against the ground. Visually confirm that there is no movement between the linkage and the work tool and the locking pins are properly fixed.

i04934902

Hammer Operation (If Equipped)

SMCS Code: 5705-WTL

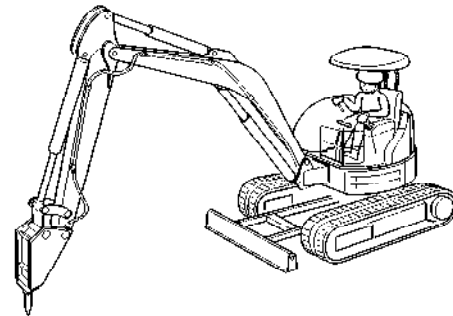

Illustration 115

g00821410

NOTICE

Selection of a hydraulic hammer must be done with extra care. Use of a hydraulic hammer not recommended by Caterpillar could result in structural damage to the machine. Consult your Caterpillar dealer for hydraulic hammer information.

Only use the hydraulic hammer to break rocks, concrete, and other hard objects. Before you start hydraulic hammer operation, place the machine on a level, stable surface. If the machine must be placed on a slope or on a rough surface, be careful during operation.

Operation Section If Equipped

Make sure that the machine is equipped with a polycarbonate shield. However, the limited operating range has to be observed, see illustration 116. When visibility is restricted due to rain, snowfall, dust etc., the work has to be stopped. Resume work only if visibility is no longer restricted. Wear protective equipment such as a hard hat and protective goggles before you start hydraulic hammer operation.

NOTICE

In order to avoid structural damage to the host machine or the hydraulic hammer, comply with the following:

Do not attempt to break rocks or concrete by burying the hammer tool completely into the rocks or concrete.

Do not apply a prying force to the hammer tool in order to remove the hammer tool from the material.

NOTICE

Frequent idle strokes (blank firing) have a deteriorating effect on the hammer. Do not operate the hammer without proper down pressure against the object.

Do not allow the hydraulic hammer to continuously operate at one location and for more than 1 minute. Change the location of the machine and repeat the procedure. Failure to change the location of the machine could cause the hydraulic oil to overheat. Overheated hydraulic oil could damage the cylinder seals.

Stop hydraulic hammer operation immediately if any of the hydraulic hoses are twisting rapidly. Consult your Caterpillar dealer for the necessary repairs.

NOTICE

Do not use the dropping force of the hydraulic hammer to break rocks or other hard objects. This could cause structural damage to the machine.

Do not use the sides or back of the hydraulic hammer to move rocks or other hard objects. Doing this could cause damage not only to the hammer but to stick or boom cylinder.

Do not operate the hydraulic hammer with any of the cylinders fully retracted or extended. Doing this could cause structural damage to the machine, resulting in reduced machine life.

Do not use the hydraulic hammer to lift an object.

Do not operate the hydraulic hammer while the stick is vertical to the ground. This type of operation could allow the stick cylinder to vibrate excessively.

Do not operate the hydraulic hammer on objects in water. This type of operation could cause the chisel to rust and the seal on the sliding section to be damaged.

Operate the attachment control levers carefully in order to keep the hydraulic hammer's chisel from hitting the boom.

Do not operate the hydraulic hammer with the upper structure sideways to the undercarriage. Before you start hydraulic hammer operation, place the upper structure in the recommended position that is shown in the following illustration. Any other operating positions could make the machine unstable. Any other operating positions could place excessive loads on the undercarriage.

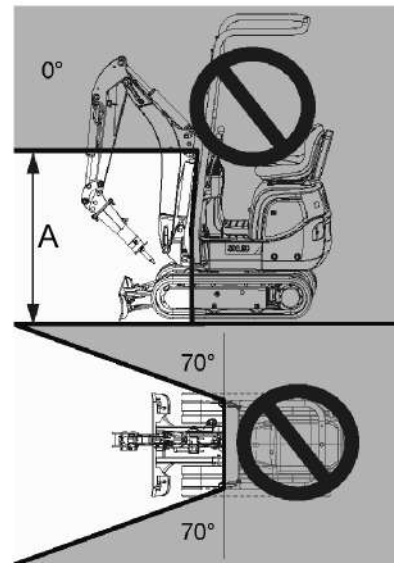

Illustration 116

g03107937

(A) 1200 mm (3 ft 11 inch)

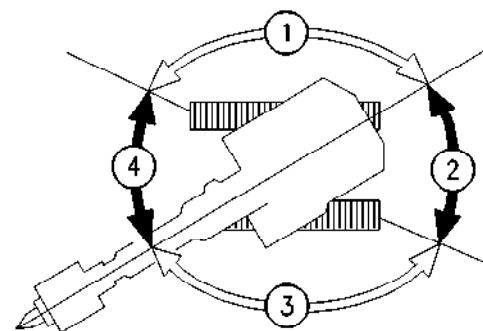

Illustration 117

g00101503

- (1) Incorrect position
- (2) Correct position
- (3) Incorrect position
- (4) Correct position

i04458009

Blade Operation

SMCS Code: 6060

NOTICE

The machine can be damaged if the adjustable gauge undercarriage and the stabilizer blade are set to different widths (for instance when driving through a door).

Adjust the stabilizer blade and the adjustable gauge undercarriage to the same widths when operating the machine.

Reducing the Width of the Stabilizer Blade

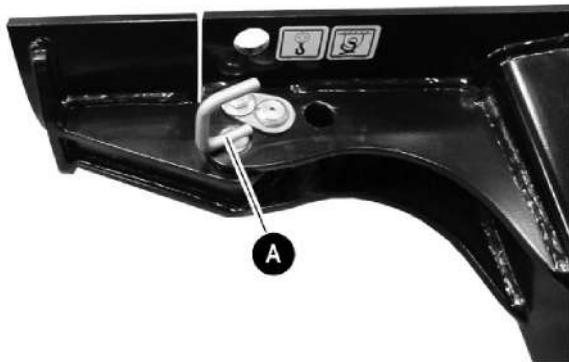

Illustration 118

g02643458

1. Raise the stabilizer blade to about 1-2 cm (0.39-0.79 inch).
2. Pull out pins (A) on either side.

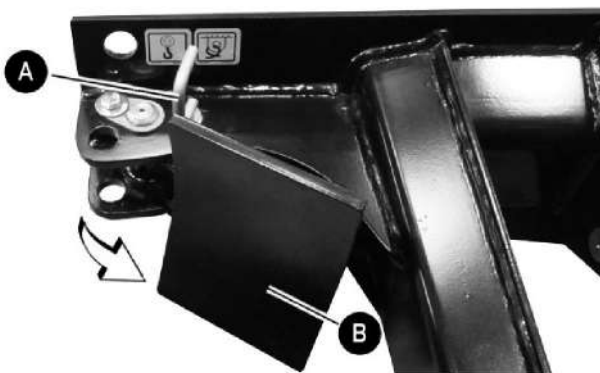

Illustration 119

g02643459

3. Fold in the stabilizer blade extensions (B) on either side.

4. Insert pins (A) on either side.

Increasing the Width of the Stabilizer Blade

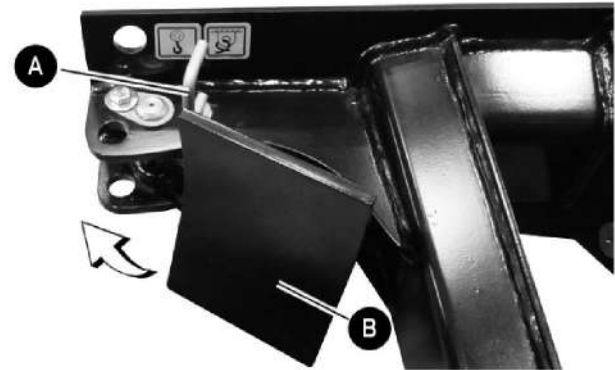

Illustration 120

g02643460

1. Raise the stabilizer blade to about 1-2 cm (0.39-0.79 inch).
2. Pull out pins (A) on either side.
3. Fold out the stabilizer blade extensions (B) on either side.

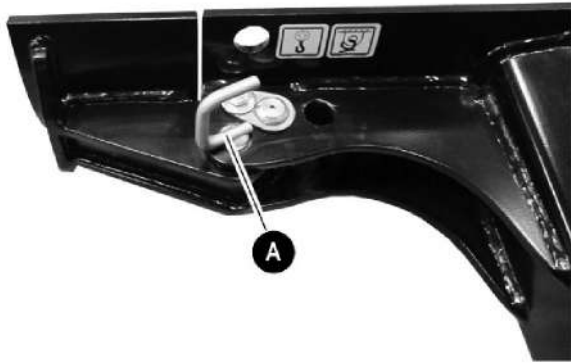

Illustration 121

g02643458

4. Insert pins (A) on either side.

i04302413

Rubber Belt Track Operation

SMCS Code: 4198

The rubber part of the track assembly can easily be damaged during operation. Operate the machine with the rubber belt only if damage to the rubber belt is shallow and the damage is not harmful. However, any harmful damage to the rubber can cause the following serious problems to the entire track assembly:

- Early wear of iron core.
- Early wear of track grousers.
- Fracture of iron core.
- Fracture of track grousers.
- Cuts of steel cords
- Rubber flaking off
- Disengagement of sprocket

Such a failed track assembly needs to be replaced as a unit. In order to minimize the replacement of the track, observe the following items. In order to maximize the performance of the track, observe the following items:

- Avoid Traveling at sites for demolition.
- Traveling at these sites should be avoided particularly when the machine is being swung at the same time.
- Avoid operation under salty conditions.
- Avoid combined operation of travel and swing with excessive load at rough terrain.

- Avoid operation at rocky sites.
- Avoid suddenly swinging the machine when the machine is Traveling on pavement.
- Use the rubber belt tracks at temperatures within -15°C (5°F) to 38°C (100.4°F). Avoid operation on hot surfaces.
- Rubber belt tracks are less stable than steel tracks. Side-to-side movement of the machine should be done carefully.
- If the sprockets are badly worn, use a new sprocket for replacement.
- Be sure that the tracks are free of oily materials such as fuel, hydraulic oil, grease, etc.
- Avoid going over sharp obstacles. Decreased life of the track, fracture of the track grousers and cut steel cords can occur.
- Track Tension must be correctly maintained and checked regularly.
- Disengagement of the track could occur if the track gets clear of the track roller. This could happen while the machine travels over an obstacle.

Parking

i04302391

Stopping the Machine

SMCS Code: 7000

WARNING

Deactivation of the controls and drive levers does not prevent the blade, boom swing, or auxiliary circuit functions from moving if the blade lever or a foot pedal is moved.

Personal injury or death may occur from sudden machine movement.

Note: There may be regulations that define the requirements for the operator and/or support personnel to be present when the engine is running.

Park on a level surface. If the machine must be parked on a grade, chock the tracks securely.

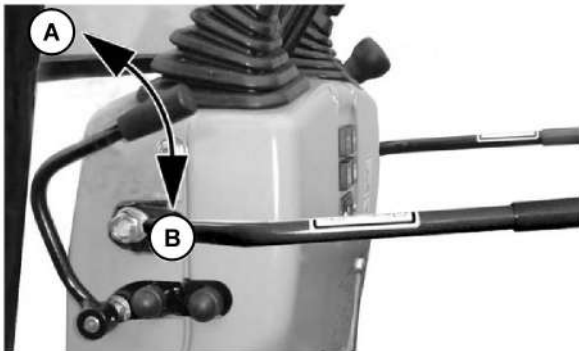

Illustration 122

g02466621

1. Push forward (A) on the governor control lever in order to reduce engine speed.

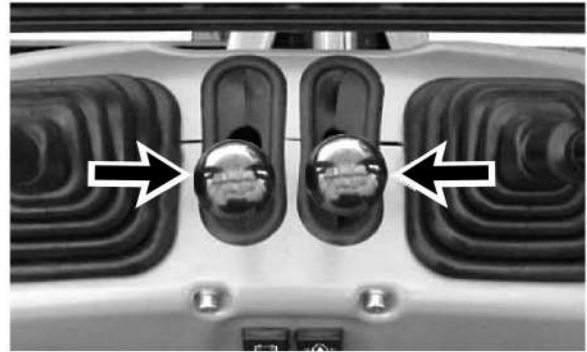

Illustration 123

g02466622

2. Move the left and right travel levers slowly to the STOP position in order to stop the machine.

Note: Avoid sudden stops. Sudden stops can damage the machine. Slow down and bring the machine to a smooth stop.

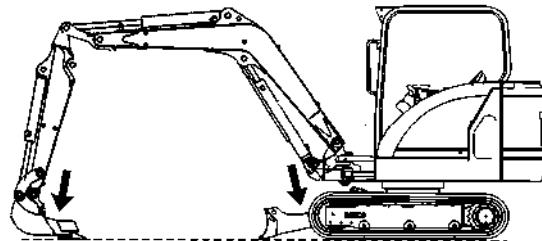

Illustration 124

g01178608

3. Lower the work tool and the blade to the ground. Apply a slight downward pressure.

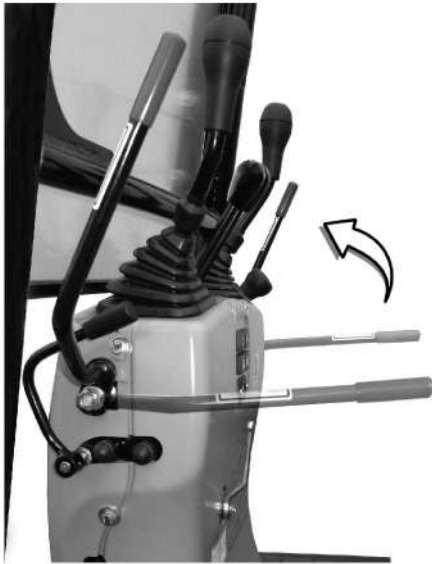

Illustration 125

g02466623

4. Raise the hydraulic lockout control to the RAISED position in order to deactivate the controls and drive levers.

i02220234

Freezing Conditions

SMCS Code: 7000

If freezing temperatures are expected, remove the mud and the dirt from each track roller frame. Park the machine on wood planks. Use the following procedure to clean each track roller frame.

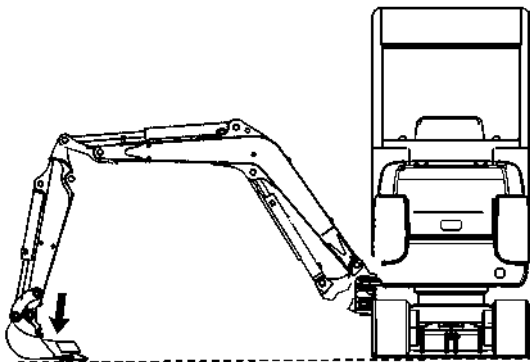

Illustration 126

g01123798

1. Position the boom over one side of the machine.

2. Use boom down pressure in order to lift the track on one side off the ground. Operate the track in the forward direction. Then operate the track in reverse. Continue this procedure until the maximum amount of material is thrown off the track.
3. Lower the track onto the wood planks.
4. Repeat the procedure for the other track.
5. Clean the area around the skid plate that is located on top of the track roller frame and around the track rollers.
6. Lower the attachment onto a wood plank.

i04289149

Stopping the Engine

SMCS Code: 1000; 7000

NOTICE

Stopping the engine immediately after it has been working under load can result in overheating and accelerated wear of the engine components.

1. Stop the machine and lower all work tools to the ground.
2. Turn off all auxiliary electrical equipment.
3. Run the engine at low idle for 5 minutes.

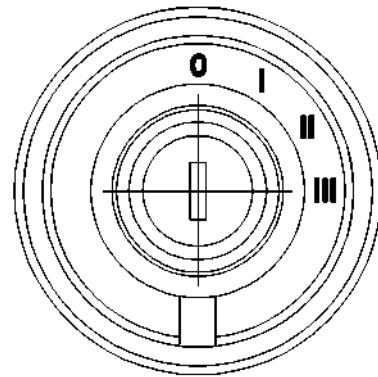

Illustration 127

g02475385

4. Turn the engine start switch key to the OFF position and remove the engine start switch key.



Off – The engine is stopped with the key in this position.

Stop the Engine if an Electrical Malfunction Occurs

i07735116

Lower all attachments and the blade to the ground. Turn the engine start switch key to the OFF position. If the engine does not stop, perform the following procedure.

1. Open the engine cover that is located beneath the operator seat.

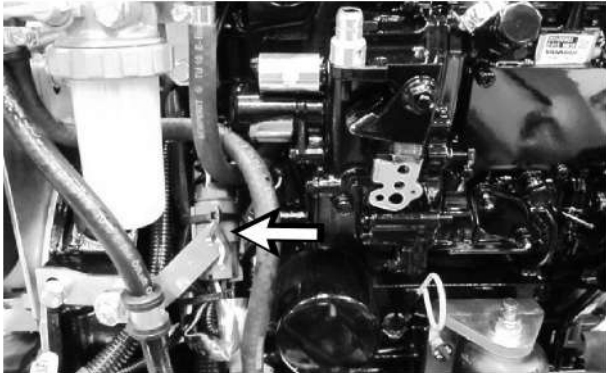

Illustration 128

g02475388

2. Disconnect the engine stop solenoid plug from the wiring loom and the engine will stop.

Note: Do not operate the machine again until the malfunction has been corrected, and the plug reconnected and fixed with cable straps.

i04278009

Leaving the Machine

SMCS Code: 7000

1. Remove the engine start switch key.

Removing the key will prevent unauthorized persons from starting the engine or from turning on the lights.
2. Use the handholds when you exit the machine. Face the machine and use both hands. Step from the operator stand to the ground. Make sure that the rubber mat is clear of debris before you dismount.
3. Inspect the engine compartment for debris. Clean out any debris and any paper in order to avoid a fire.
4. Lock the engine cover.

Machine Storage and Specified Storage Period

SMCS Code: 7000

Machine Storage

The Safety Section of this Operation and Maintenance Manual contains storage information for fuels, lubricants, and ether (if equipped).

The Operation Section of this Operation and Maintenance Manual contains information for short-term storage of this machine, including engine shutdown, parking, and instructions for leaving the machine.

For detailed steps on long-term storage refer to Special Instruction, SEHS9031, "Storage Procedure for Caterpillar Products".

Specified Storage Period

The specified storage period of this machine is 1 year.

After the specified storage period has expired, consult your Cat dealer for inspect, repair, rebuild, install remanufactured, or install new components, and disposal options, and to establish a new specified storage period.

If a decision is made to remove the machine from service, refer to Decommissioning and Disposal for further information.

Transportation Information

i02005176

Shipping the Machine

SMCS Code: 7000; 7500

Investigate the travel route for overpass clearances. Make sure that there will be adequate clearance for the machine.

Before you load the machine onto the trailer, remove ice, snow, or other slippery material from the loading dock and from the truck bed. Removal of ice, snow, or other slippery material will prevent the slipping of the machine as you load the machine. Removing ice, snow, or other slippery material will prevent the machine from moving in transit.

NOTICE

Obey all state and local laws governing the weight, width and length of a load.

Make sure the cooling system has proper antifreeze if moving machine to a colder climate.

Observe all regulations governing wide loads.

Do not use a fork lift to lift the machine. Using a fork lift to move your machine can result in property damage.

Choose the flattest ground when you load the machine or when you unload the machine.

1. Before you load the machine and before you unload the machine, chock the trailer wheels or chock the rail car wheels.
2. When you use loading ramps, make sure that the loading ramps have adequate length, adequate width, and adequate strength. In addition, make sure that the surfaces of the loading ramps are clean. This will help prevent the machine from sliding in all types of weather conditions. This will allow the machine to move on the ramps smoothly.
3. Maintain the slope of the loading ramps within 15 degrees of the ground.
4. Minimize any step between the base of the loading ramps and the ground.
5. Clean the tracks on the machine in order to prevent any slippage.

Loading The Machine

1. Position the machine so that the machine can drive straight up the loading ramps. Position the machine so that the front linkage and the dozer blade will be the first machine components to travel up the loading ramps. Make sure that the dozer blade is raised up.
2. Extend the front linkage forward over the trailer bed in order to help maintain balance.
3. Use caution when you travel over the areas around the loading ramp joints. Maintain the balance point of the machine.
4. After you load the machine onto the trailer be sure that the machine is properly positioned on the trailer bed.
5. Slowly, swing the upper structure for 180° and carefully move the machine toward the front of the trailer or the rail car.
6. Refer to the Operation and Maintenance Manual, "Lifting and Tying Down the Machine" for information on tying down the machine.

Unloading The Machine

1. Position the machine so that the machine can drive straight down the loading ramps. Position the machine so that the front linkage will be the first machine component to travel down the loading ramps. Position the machine so that the dozer blade will be the last machine component to travel down the loading ramps. Make sure that the dozer blade is raised up.
2. Extend the front linkage forward over the ramps. While you travel down the loading ramps, adjust the front linkage in order to allow the work tool to remain close to the ground. This will prevent the machine from tipping forward.

- Use caution when you travel over the areas around the loading ramp joints in order to maintain the balance point of the machine.

i05565553

Adjustable Gauge Undercarriage Frame

SMCS Code: 4150-VAR

The undercarriage will not expand evenly. When you are expanding the undercarriage, be sure to expand the undercarriage completely. If the undercarriage is not fully expanded, the upper structure can slide when the machine is operated. The machine can overturn if the upper structure slides.

The undercarriage will not retract evenly. When you are retracting the undercarriage, be sure to retract the undercarriage completely. If the undercarriage is not fully retracted, the upper structure can slide when the machine is operated. The machine can overturn if the upper structure slides.

Expand the undercarriage in an open area on flat, solid ground. The undercarriage should always be expanded except when you travel through narrow passages.

Expanding the Undercarriage and Retracting the Undercarriage

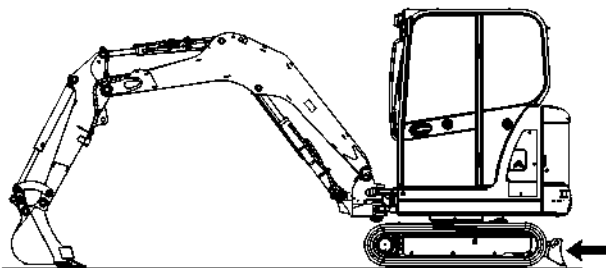

Illustration 129

g01178667

- Swing the upper structure in order to position the dozer blade behind the operator.

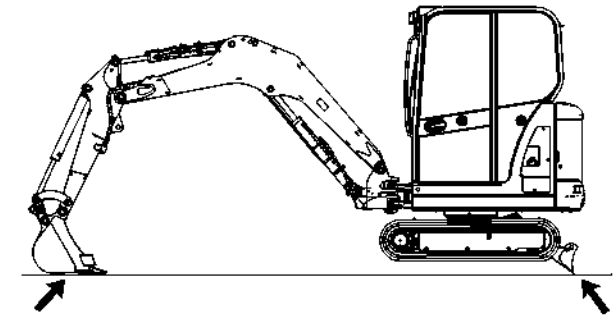

Illustration 130

g01178668

- Apply down pressure with the dozer blade in order to lift the rear of the machine off the ground. Simultaneously hold the joystick controls in the BOOM LOWER position and the STICK OUT position until the tracks are off the ground.

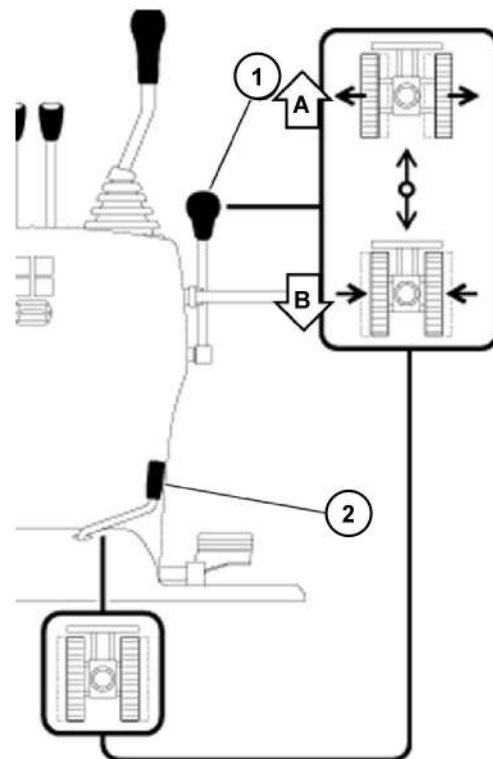

Illustration 131

g02466598

- Rotate lever (2) to the right and make sure that the lever is in the vertical position in order to control the adjustable gauge undercarriage.

4. Move the control lever (1) forward (A) in order to expand the undercarriage. Move the control lever (1) backward (B) in order to retract the undercarriage. Release control lever (1).

Note: While expanding and retracting the undercarriage, the dozer blade may lift slightly and may cause the rear of the machine to lift or lower slightly.

5. Rotate lever (2) to the left and make sure that the lever has returned to the horizontal position in order to control the blade.
6. Simultaneously hold the joystick controls in the BOOM RAISE position and the STICK IN position in order to lower the front of the machine to the ground. Carefully lower the rear of the machine to the ground by using the dozer blade control.
7. Swing the upper structure in order to place the dozer blade in the front of the machine.

i05603329

Lifting and Tying Down the Machine

SMCS Code: 7000; 7500

WARNING

The machine could come loose from the lifting device and cause personal injury or death. Do not allow anyone inside the machine during the lifting procedure of the machine. Do not allow anyone under or around the machine during the lifting procedure. Stay clear!

NOTICE

Improper lifting or tiedowns can allow load to shift and can cause injury and damage.

Refer to Operation and Maintenance Manual, "Specifications" for specific weight information.

Use proper rated cables and slings for lifting. The crane should be positioned so that the machine is lifted parallel to the ground.

Positioning the Machine for Lifting

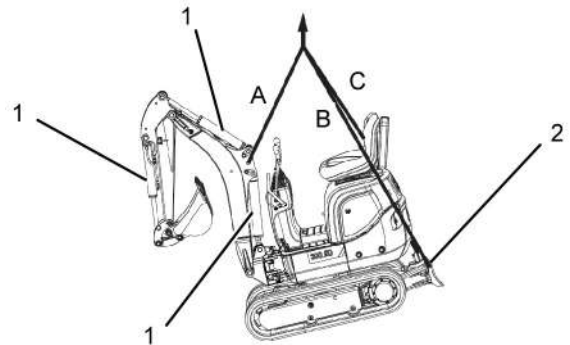

Illustration 132

g02466797

1. Raise the blade (2).
2. Position the boom in a straight ahead position.
3. Retract the boom cylinder, extend the stick cylinder, and work tool cylinder (1) to the end of the stroke.
4. Swing the upper structure so that the blade (2) is to the rear of the machine.
5. Stop the engine. Raise the hydraulic lockout control and dismount the machine. Lock the engine cover.

Lifting the Machine

Note: Ensure that the undercarriage is fully expanded before you lift the machine. Ensure that an empty standard bucket is installed on the machine. Ensure that the polycarbonate shield is removed and the ROPS bar (if equipped) lowered before you fasten the slings and lift the machine.

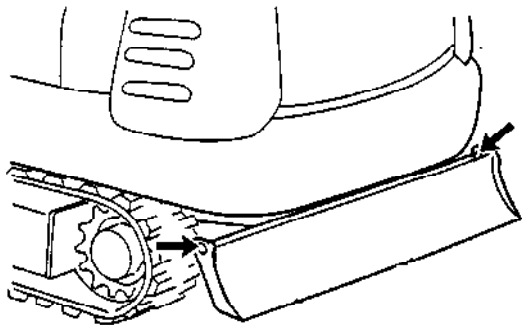

Illustration 133

g00309343

1. Attach shackles to the lifting eyes in the ends of the blade and fasten slings to the shackles.

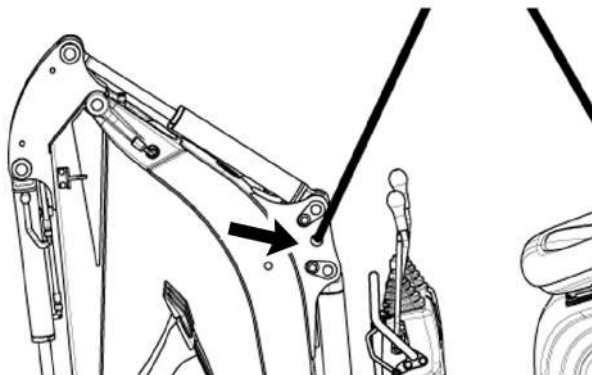

Illustration 134

g02461222

2. Attach a shackle to the lifting eye in the middle bracket of the boom. Fasten a sling to the shackle.
3. Use lifting gears that match the required lengths.

Table 14

(A)	1054 mm (3 ft 5 inch)
(B) and (C)	1718 mm (5 ft 8 inch)

4. Raise the machine slowly in order to make sure that the machine stays in a horizontal position.

Tying Down the Machine

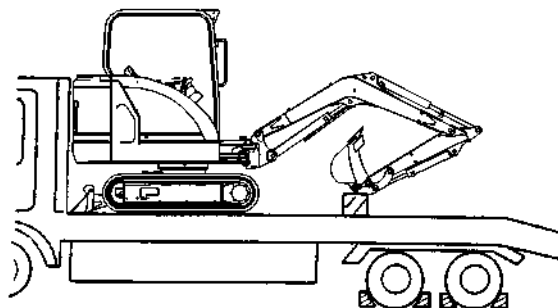

Illustration 135

g01178554

1. Lower the blade to the trailer.
2. Extend the bucket and stick cylinders to the end of the stroke.
3. Lower the boom slowly in order to rest the bucket control linkage on a block of wood.
4. Stop the engine and remove the key.
5. Move all of the hydraulic control levers several times in order to relieve any trapped pressure.
6. Move the hydraulic lockout control to the RAISED position.
7. Lock the engine cover.
8. Remove and secure the polycarbonate shield, if equipped.

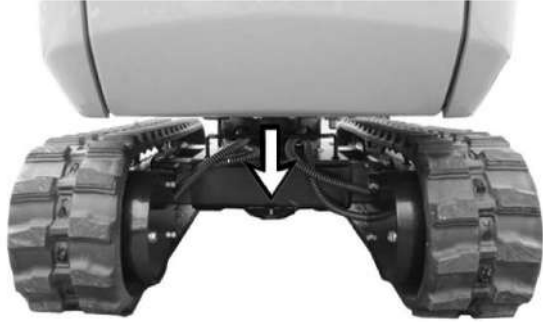

Illustration 136

g03566125

- 9.** Chock the tracks. Install tie-downs on the front eye on the blade in order to prevent shifting in transit. Install tie-downs on the bucket control linkage in order to prevent the boom from shifting. Install tie-downs on the rear eye on the lower frame in order to prevent shifting in transit.

Note: Use protectors between the machine and tie-downs.

- 10.** Separately tie down all work tools that will accompany the machine. Refer to the owner manual for the work tools for instructions on tying down the individual work tools.

Towing Information

i05603309

Towing the Machine

SMCS Code: 7000

NOTICE

Towing this machine is not possible due to the inability of the travel motors to freewheel.

If the machine is disabled, the machine must be lifted onto a trailer in order to be transported.

The machine can be lifted. Refer to Operation and Maintenance Manual, "Lifting and Tying Down the Machine" for the lifting procedure.

Engine Starting (Alternate Methods)

i02016499

Engine Starting with Jump Start Cables

SMCS Code: 1000; 7000

WARNING

Failure to properly service the batteries may cause personal injury.

Prevent sparks near the batteries. They could cause vapors to explode. Do not allow the jump start cable ends to contact each other or the machine.

Do not smoke when checking battery electrolyte levels.

Electrolyte is an acid and can cause personal injury if it contacts skin or eyes.

Always wear eye protection when starting a machine with jump start cables.

Improper jump start procedures can cause an explosion resulting in personal injury.

Always connect the battery positive (+) to battery positive (+) and the battery negative (-) to battery negative (-).

Jump start only with an energy source with the same voltage as the stalled machine.

Turn off all lights and accessories on the stalled machine. Otherwise, they will operate when the energy source is connected.

NOTICE

When jump starting the engine with another machine, make sure that the machines do not touch. This could prevent damage to engine bearings and electrical circuits.

Severely discharged maintenance free batteries do not fully recharge from the alternator after jump starting. The batteries must be charged to proper voltage with a battery charger. Many batteries thought to be unusable are still rechargeable.

Use only equal voltage for starting. Check the battery and starter voltage rating of your machine. Use only the same voltage for jump starting. Use of a welder or higher voltage damages the electrical system.

Refer to Special Instruction, SEHS7633, "Battery Test Procedure" available from your Caterpillar dealer, for complete testing and charging information.

1. Lower the equipment to the ground. Move all controls to the HOLD position. Move the hydraulic lockout control (lever) to the LOCKED position.
2. Turn the start switch on the stalled machine to the OFF position. Turn off all accessories.
3. Move the machine that is being used as an electrical source near the stalled machine so that the jump start cables reach the stalled machine.
Do not allow the machines to contact each other.
4. Stop the engine of the machine that is being used as an electrical source. If you are using an auxiliary power source, turn off the charging system.
5. Ensure that battery caps on both machines are tight and correctly placed. Ensure that batteries in the stalled machine are not frozen. Make sure that the batteries have enough electrolyte.

Note: The positive terminal of the 12 volt system of the source and the negative terminal of the 12 volt system of the source must be identified correctly before the jumper cables are connected. The positive terminal of the 12 volt system of the discharged battery must be identified correctly before the jumper cables are connected.

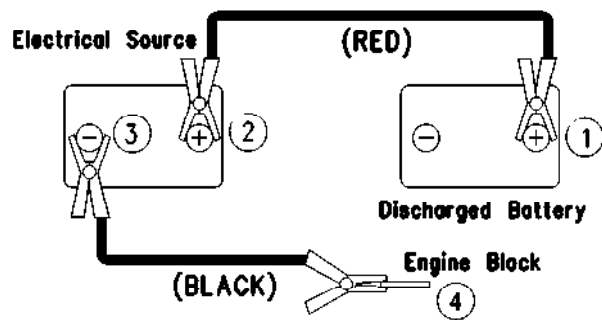

Illustration 137

g00818210

6. The positive ends of the jump start cable are red. Connect one positive end of the jump start cable to positive cable terminal (1) of the discharged battery.
Do not allow the positive cable clamps to contact any metal except for the battery terminals.
7. Connect the other positive end of the jump start cable to positive cable terminal (2) of the electrical source.
8. Connect one negative end of the jump start cable to negative cable terminal (3) of the electrical source.
9. Finally, connect the other negative end of the jump start cable to engine block (4) of the stalled machine. Do not connect the jump start cable to the battery post. Do not allow the jump start cables to contact the battery cables, the fuel lines, the hydraulic lines, or any moving parts.
10. Start the engine of the machine that is being used as an electrical source or energize the charging system on the auxiliary power source.
11. Wait at least two minutes before you attempt to start the stalled machine. This will allow the batteries in the stalled machine to partially charge.
12. Attempt to start the stalled engine. See Operation and Maintenance Manual, "Engine Starting" for the correct starting procedure.
13. Immediately after you start the stalled engine, disconnect the jump start cables in reverse order.

Maintenance Section

Maintenance Access

i04281089

Access Door and Cover Locations

SMCS Code: 726A-CH

Engine Cover

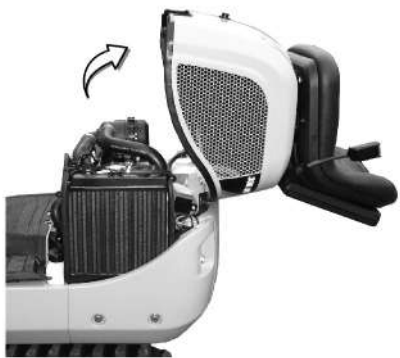

Illustration 138

g02448276

Lubricant Viscosities and Refill Capacities

i08015121

Lubricant Viscosities

SMCS Code: 7581

General Information for Lubricants

The footnotes are a key part of the tables. Read ALL footnotes that pertain to the machine compartment in question.

Selecting the Viscosity

To select the proper oil for each machine compartment, refer to the "Lubricant Viscosity for Ambient Temperature" table. Use the oil type AND oil viscosity for the specific compartment at the proper ambient temperature.

The proper oil viscosity grade is determined by the minimum ambient temperature (the air in the immediate vicinity of the machine). Measure the temperature when the machine is started and while the machine is operated.

Consult your Cat dealer if additional information is needed.

NOTICE

Not following the recommendations found in this manual can lead to reduced performance and compartment failure.

Engine Oil

Cat oils have been developed and tested to provide the full performance and life that has been designed and built into your machines engine.

Table 15

Lubricant Viscosities for Ambient Temperatures						
Compartment or System	Oil Type and Performance Requirements	Oil Viscosities	°C		°F	
			Min	Max	Min	Max
Engine Crankcase	Cat DEO	SAE 10W-30	-20	30	-4	86
		SAE 15W-40	-15	40	5	104

Hydraulic Systems

The following are the approved oils for use in this Cat machine hydraulic system:

Table 16

Lubricant Viscosities for Ambient Temperatures						
Compartment or System	Oil Type and Performance Requirements	Oil Viscosities	°C		°F	
			Min	Max	Min	Max
Hydraulic System	Cat HYDO Advanced 10	SAE 10W	-20	40	-4	104
	Cat BIO HYDOTM Advanced	SAE 10W	-30	45	-22	113

Special Lubricants

Grease

Each pin joint should be flushed with the new grease. Ensure that all old grease is removed. Failure to meet this requirement may lead to failure of a pin joint.

Table 17

Recommended Grease						
Compartment or System	Grease Type	NLGI Grade	°C		°F	
			Min	Max	Min	Max
Lubrication Points	Cat Advanced 3 Moly	NLGI Grade 2	-20	40	-4	104

Diesel Fuel Recommendations



Illustration 139

g02476430

Diesel fuel must meet “Caterpillar Specification for Distillate Fuel” and the latest versions of “ASTM D975” or “EN 590” to ensure optimum engine performance. Refer to Special Publication, SEBU6250, “Caterpillar Machine Fluids Recommendations” for the latest fuel information and for Cat fuel specification. This manual may be found on the web at Safety.Cat.com.

Failures that result from the use of improper fuels are not Caterpillar factory defects. Therefore the cost of repairs would not be covered by a Caterpillar warranty.

Note: Ultra Low Sulfur Diesel Fuel (ULSD) is recommended, however, Caterpillar does not require the use of ULSD in engines that are not equipped with after treatment devices.

Biodiesel

Note: Up to B7 biodiesel blend level is acceptable for use. Diesel with a higher biodiesel portion or pure biodiesel is NOT acceptable.

Biodiesel is a fuel that can be made from various renewable resources that include vegetable oils, animal fat, and waste cooking oil. Soybean oil and rapeseed oil are the primary vegetable oil sources. To use any of these oils or fats as fuel, the oils, or fats are chemically processed (esterified). The water and contaminants are removed.

U.S. distillate diesel fuel specification “ASTM D975-09a” includes up to B5 (5 percent) biodiesel. Currently, any diesel fuel in the U.S. may contain up to B5 biodiesel fuel.

European distillate diesel fuel specification “EN 590” includes up to B5 (5 percent) and in some regions up to B7 (7 percent) biodiesel. Any diesel fuel in Europe may contain up to B5 or in some regions up to B7 biodiesel fuel.

Note: The diesel portion used in the biodiesel blend must be Ultra Low Sulfur Diesel (15 ppm sulfur or less, per “ASTM D975”). In Europe the diesel fuel portion used in the biodiesel blend must be sulfur free diesel (10 ppm sulfur or less, per “EN 590”). The final blend must have 15 ppm sulfur or less.

All the guidelines and requirements are provided in the latest revision of Special Publication, SEBU6250, "Caterpillar Machine Fluids Recommendations". This manual may be found on the web at Safety.Cat.com.

Coolant Information

The information provided in this "Coolant Recommendation" section should be used with the "Lubricants Information" provided in the latest revision of Special Publication, SEBU6250, "Caterpillar Machine Fluids Recommendations". This manual may be found on the web at Safety.Cat.com.

The following type of coolants may be used but not mixed with each other:

Approved for

S/N: LJM1-01249; LJ21-00199

– A coolant that fulfills "ASTM D4985" plus distilled water.

Approved for

S/N: LJM01250-Up; LJ200200-Up

– Cat ELC (Extended Life Coolant)

NOTICE

Never use water alone as a coolant. Water alone is corrosive at engine operating temperatures. In addition, water alone does not provide adequate protection against boiling or freezing.

NOTICE

Mixing ELC with other products will reduce the effectiveness of the coolant.

This could result in damage to cooling system components.

If Caterpillar products are not available and commercial products must be used, make sure they have passed the Caterpillar EC-1 specification for pre-mixed or concentrate coolants and Caterpillar Extender.

i05602977

Capacities (Refill)**SMCS Code:** 1000; 7000

Table 18

Approximate Refill Capacities				
Component or System		Liters	US gal	Recommended Type
Fuel Tank		7	1.85	Diesel Fuel
Cooling System	S/N: LJM1-01249; LJ21-00199	2.9	.77	"ASTM D4985"
	S/N: LJM01250-Up; LJ200200-Up			Caterpillar Extended Life Coolant (ELC)
Engine Crankcase with Filter		2.5	.66	Refer to Operation and Maintenance Manual, "Lubricant Viscosities".
Hydraulic System ⁽¹⁾		13.8	3.64	

⁽¹⁾ The amount of hydraulic fluid that is needed to refill the hydraulic system after performing Operation and Maintenance Manual, "Hydraulic System Oil - Change"

i07445339

S·O·S Information**SMCS Code:** 1000; 1348; 3080; 4050; 5050; 7000; 7542-008

S·O·S Services is a highly recommended process for Cat customers to use in order to minimize owning and operating cost. Customers provide oil samples, coolant samples, and other machine information. The dealer uses the data in order to provide the customer with recommendations for management of the equipment. In addition, S·O·S Services can help determine the cause of an existing product problem.

Refer to Special Publication, SEBU6250, "Caterpillar Machine Fluid Recommendations" for detailed information concerning S·O·S Services.

The effectiveness of S·O·S Services is dependent on timely submission of the sample to the laboratory at recommended intervals.

Refer to the Operation and Maintenance Manual, "Maintenance Interval Schedule" for a specific sampling location and a service hour maintenance interval.

Consult your Cat dealer for complete information and assistance in establishing an S·O·S program for your equipment.

Maintenance Support

i07477696

Prepare the Machine for Maintenance

SMCS Code: 1000; 7000

Refer to the following procedure before you perform any maintenance to the machine.

WARNING

Personal injury can result from hydraulic oil pressure and hot oil.

Hydraulic oil pressure can remain in the hydraulic system after the engine has been stopped. Serious injury can be caused if this pressure is not released before any service is done on the hydraulic system.

Make sure all of the attachments have been lowered, oil is cool before removing any components or lines. Remove the oil filler cap only when the engine is stopped, and the filler cap is cool enough to touch with your bare hand.

NOTICE

Care must be taken to ensure that fluids are contained during performance of inspection, maintenance, testing, adjusting, and repair of the product. Be prepared to collect the fluid with suitable containers before opening any compartment or disassembling any component containing fluids.

Refer to Special Publication, PERJ1017, "Dealer Service Tool Catalog" for tools and supplies suitable to collect and contain fluids on Cat® products.

Dispose of all fluids according to local regulations and mandates.

Note: Permit only one operator on the machine. Keep all other personnel away from the machine or in view of the operator.

1. Park the machine on a dry, level, solid surface that is free of any debris.

Note: The surface must be solid enough to support the weight of the machine and any tooling that is used to support the machine.

2. Engage the parking brake. Place wheel blocks in front and behind the wheels or tracks.
3. Lower all work tools to the ground.
4. Stop the engine.

5. Release the pressure in the hydraulic system. Refer to Operation and Maintenance Manual, "System Pressure Release" for more information.

Perform a visual inspection first. If the visual checks are completed but the problem has not been identified, perform operational checks. If the problem has not been identified, perform instrument tests. This procedure will help to identify system problems.

i05615694

Service Interval Chart

SMCS Code: 7000

The service interval chart is located at the operator station.

Refer to this Operation and Maintenance Manual, "Maintenance Interval Schedule" for the correct maintenance intervals and procedures that are specific to your machine.

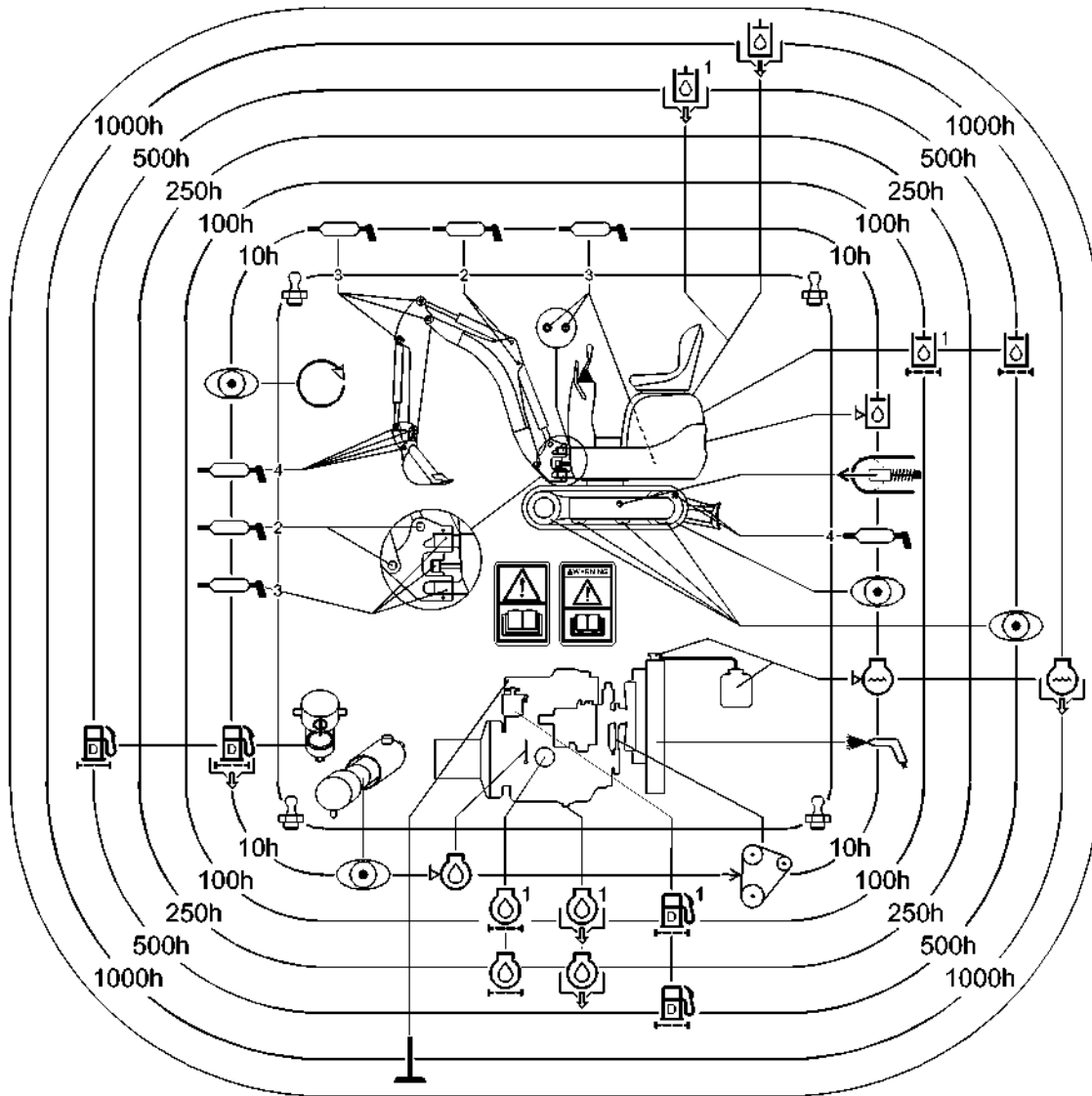

Illustration 140

g03566258



Visual check – Perform a visual check.



Coolant level – Check the coolant level.



Cooling system coolant – Change the cooling system coolant.



Engine valve lash – Check the engine valve lash and adjust if necessary.



Engine oil level – Check the engine oil level.



Engine oil – Change the engine oil.



Engine oil filter – Change the engine oil filter.



Belt – Check the belt tension.



Fuel system filter – Replace the fuel system filters.



Fuel system water separator – Drain the water separator.



Grease zerk – Lubricate the designated locations.



Hydraulic oil level – Check the hydraulic oil level.



Hydraulic oil – Change the hydraulic oil.



Hydraulic oil filter – Change the hydraulic oil filter.



Track tension – Check the track tension.

i07937278

System Pressure Release

SMCS Code: 1250-553-PX; 1300-553-PX; 1350-553-PX; 5050-553-PX; 6700-553-PX; 7540-553-PX

WARNING

Personal injury or death can result from sudden machine movement.

Sudden movement of the machine can cause injury to persons on or near the machine.

To prevent injury or death, make sure that the area around the machine is clear of personnel and obstructions before operating the machine.

Coolant System

WARNING

Pressurized system: Hot coolant can cause serious burn. To open cap, stop engine, wait until radiator is cool. Then loosen cap slowly to relieve the pressure.

To relieve the pressure from the coolant system, turn off the machine. Allow the cooling system pressure cap to cool. Remove the cooling system pressure cap slowly in order to relieve pressure.

Hydraulic System

The release of hydraulic pressure in a hydraulic circuit is required before service is performed to that hydraulic circuit. Release the pressure in the following hydraulic circuits before any hydraulic lines are disconnected or removed from that hydraulic circuit.

- Boom hydraulic circuit

- Stick hydraulic circuit
- Bucket hydraulic circuit
- Swing hydraulic circuit
- Travel hydraulic circuit
- Attachment hydraulic circuits (if equipped)
- Pilot hydraulic circuit
- Return hydraulic circuit

Note: Refer to the Disassembly and Assembly Manual for additional information concerning service of the components of specific hydraulic circuits.

Release of Hydraulic Pressure from the Main Hydraulic System

WARNING

Personal injury can result from hydraulic oil pressure and hot oil.

Hydraulic oil pressure can remain in the hydraulic system after the engine has been stopped. Serious injury can be caused if this pressure is not released before any service is done on the hydraulic system.

Make sure all of the work tools have been lowered to the ground, and the oil is cool before removing any components or lines. Remove the oil filler cap only when the engine is stopped, and the filler cap is cool enough to touch with your bare hand.

NOTICE

Care must be taken to ensure that fluids are contained during performance of inspection, maintenance, testing, adjusting, and repair of the product. Be prepared to collect the fluid with suitable containers before opening any compartment or disassembling any component containing fluids.

Refer to Special Publication, PERJ1017, "Dealer Service Tool Catalog" for tools and supplies suitable to collect and contain fluids on Cat® products.

Dispose of all fluids according to local regulations and mandates.

Perform the following steps to release the hydraulic system pressure from the main hydraulic system.

Note: For additional safety, wrap hydraulic joint with material that could absorb/reduce any residual pressure of oil when released. Loosen the joint slowly, pause, and carefully check hydraulic joint for tensions indicating presence of pressure or spring force in lines or components.

Maintenance Section
System Pressure Release

1. Position the machine on level ground.
2. Fully retract the stick cylinder rod. Adjust the position of the bucket so that the bucket is parallel to the ground. Lower the boom until the work tool is flat on the ground.
3. Release the system pressure from the implement and swing hydraulic circuits.

Note: Perform Step 3b through Step 3d immediately after the engine is shut off to insure adequate pilot system pressure is available to release the pressure in the hydraulic circuits.

- a. Shut off the engine.
- b. Turn the engine start switch to the ON position without starting the engine.
- c. Place the hydraulic activation control lever in the UNLOCKED position.

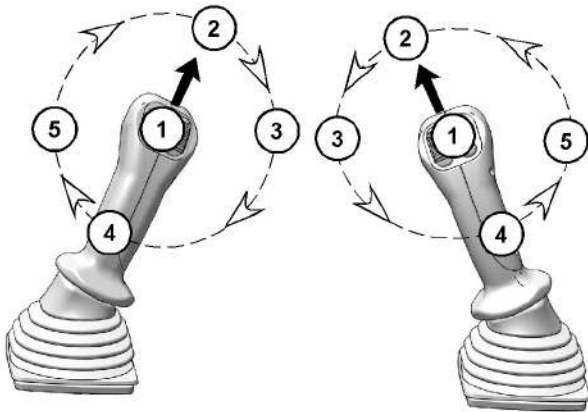

Illustration 141

g06184822

- d. Move both joysticks in a circular motion to the FULL STROKE positions multiple times until the pilot accumulator has been exhausted.

Note: Pilot pressure is required to relieve hydraulic system pressure.

- e. Place the hydraulic activation control lever in the LOCKED position.
- f. Start the engine to recharge the pilot accumulator.

Note: Do not activate any controls when recharging the pilot accumulator.

- g. Shut off the engine.

- h. Repeat Step 3b through Step 3g until the high-pressure lines have been released.

Note: Each time the accumulator is recharged, start the joysticks at different positions or rotate in the reverse direction. Doing so will ensure that the same circuit is not being relieved each time.

Note: You can also move only the joysticks or pedals of the hydraulic circuit that requires service to the full stroke positions after moving joysticks in a circular motion multiple times. This action will release the high pressure only in that single hydraulic circuit. This action will also release any pressure that might be present in the pilot hydraulic circuit.

4. Release hydraulic system pressure in the auxiliary circuits.
 - a. Start the engine to charge pilot accumulator.
 - b. Shut off the engine.

Note: Perform Step 4c through Step 4e immediately after the engine is shut off to insure adequate pilot system pressure is available to release the pressure in the hydraulic circuits.

- c. Turn the engine start switch to the ON position without starting the engine.
- d. Place the hydraulic activation control lever in the UNLOCKED position.
- e. Actuate the auxiliary circuit in both directions several times.
- f. Place the hydraulic activation control lever in the LOCKED position.
- g. Start the engine to recharge pilot accumulator.

Note: Do not activate any controls when recharging pilot accumulator.

- h. Shut off the engine.
 - i. Repeat Step 4c through Step 4f for each auxiliary circuit.

5. After releasing the hydraulic pressure in each of the desired hydraulic circuits, place the hydraulic activation control lever in the LOCKED position.
6. Turn the engine start switch to the OFF position.
7. Remove the hydraulic oil tank filler cap.
8. The pressure in the multiple hydraulic circuits that require service is now released and lines and components can be disconnected or removed from those hydraulic circuits.

Note: Pressure can build up in the auxiliary lines if the attachment is not coupled/uncoupled immediately after the pressure has been released.

Note: Refer to the Operation and Maintenance Manual, Equipment Lowering with Engine Stopped for information on lowering the work tool with the engine off.

i07746333

Welding on Machines and Engines with Electronic Controls

SMCS Code: 1000; 7000

Do not weld on any protective structure. If it is necessary to repair a protective structure, contact your Cat dealer.

Proper welding procedures are necessary to avoid damage to the electronic controls and to the bearings. When possible, remove the component that must be welded from the machine or the engine and then weld the component. If you must weld near an electronic control on the machine or the engine, temporarily remove the electronic control to prevent heat related damage. The following steps should be followed to weld on a machine or an engine with electronic controls.

1. Turn off the engine. Place the engine start switch in the OFF position.
2. If equipped, turn the battery disconnect switch to the OFF position. If there is no battery disconnect switch, remove the negative battery cable at the battery.

NOTICE

Do NOT use electrical components (ECM or sensors) or electronic component grounding points for grounding the welder.

3. Clamp the ground cable from the welder to the component that will be welded. Place the clamp as close as possible to the weld. Make sure that the electrical path from the ground cable to the component does not go through any bearing. Use this procedure to reduce the possibility of damage to the following components:
 - Bearings of the drive train
 - Hydraulic components
 - Electrical components
 - Other components of the machine

4. Protect any wiring harnesses and components from the debris and the spatter which is created from welding.
5. Use standard welding procedures to weld the materials together.

i08117863

Maintenance Interval Schedule

SMCS Code: 7000

Ensure that all safety information, warnings, and instructions are read and understood before any operation or any maintenance procedures are performed.

The user is responsible for the performance of maintenance. All adjustments, the use of proper lubricants, fluids, filters, and the replacement of components due to normal wear and aging are included. Failure to adhere to proper maintenance intervals and procedures may result in diminished performance of the product and/or accelerated wear of components.

Use mileage, fuel consumption, service hours, or calendar time, WHICH EVER OCCURS FIRST, to determine the maintenance intervals. Products that operate in severe operating conditions may require more frequent maintenance. Refer to the maintenance procedure for any other exceptions that may change the maintenance intervals.

Note: Before each consecutive interval is performed, all maintenance from the previous interval must be performed.

The following guidelines should be followed if the service hours are not met:

Items listed between 10 and 100 service hours should be performed at least every 3 months.

Items listed between 250 and 500 service hours should be performed at least every 6 months.

Items listed between 1000 service hours and 2500 service hours should be performed at least every year.

When Required

“ Battery - Recycle“	110
“ Bucket Tips - Inspect/Replace“	115
“ Film (Product Identification) - Clean“	122
“ Fuel System - Prime“	123
“ Fuses - Replace“	126
“ Oil Filter - Inspect“	132
“ Track Adjustment - Adjust“	136
“ Windows - Clean“	138

Every 10 Service Hours or Daily

“ Belt - Inspect“	112
-----------------------------	-----

“ Blade Linkage - Lubricate“	112
“ Boom, Stick and Bucket Linkage - Lubricate“	113
“ Cooling System Coolant Level - Check“	118
“ Engine Air Filter Service Indicator - Inspect“	119
“ Engine Oil Level - Check“	120
“ Fuel System Water Separator - Drain“	125
“ Horn - Test“	127
“ Hydraulic System Oil Level - Check“	130
“ Light - Test“	131
“ Radiator Core - Clean“	132
“ Rollover Protective Structure (ROPS) - Inspect“	133
“ Seat Belt - Inspect“	133
“ Sound Suppression (Covers, Panels) - Inspect/Replace“	134
“ Swing Bearing - Lubricate“	134
“ Swing Frame and Cylinder Bearings - Lubricate“	134
“ Track Adjustment - Inspect“	137
“ Travel Alarm - Test“	137
“ Undercarriage - Check“	138

Initial 50 Service Hours

“ Engine Oil and Filter - Change“	120
“ Fuel System Filter - Replace“	124
“ Hydraulic System Oil Filter (Return) - Replace“	129
“ Main Relief Valve - Check“	131
“ Swing Gear - Lubricate“	135

Initial 100 Service Hours

“ Battery Electrolyte Level - Check“	110
--	-----

Every 250 Service Hours

“ Engine Oil Sample - Obtain“	120
“ Engine Oil and Filter - Change“	120
“ Fuel Tank Cap and Strainer - Clean“	126

“ Hydraulic Control Linkage - Lubricate“ 127

Initial 500 Service Hours

“ Hydraulic System Oil - Change“ 128

Every 500 Service Hours

“ Battery Electrolyte Level - Check“ 110

“ Boom, Stick, and Frame - Inspect“ 113

“ Engine Air Filter Primary and/or Secondary Element - Replace“ 118

“ Fasteners - Check“ 122

“ Fuel System Filter - Replace“ 124

“ Fuel Tank Water and Sediment - Drain“ 126

“ Hydraulic System - Purge“ 128

“ Hydraulic System Oil Filter (Return) - Replace“ 129

“ Hydraulic System Oil Sample - Obtain“ 131

“ Main Relief Valve - Check“ 131

“ Undercarriage - Inspect“ 138

“ Visual Inspection“ 138

Initial 1000 Service Hours

“ Coolant System - Flush“ 115

Every 1000 Service Hours

“ Battery Hold-Down - Tighten“ 110

“ Battery or Battery Cable - Inspect/Replace“ 110

“ Cooling System Coolant - Change“ 116

“ Engine Valve Lash - Check/Adjust“ 121

“ Hydraulic System Oil - Change“ 128

“ Swing Gear - Lubricate“ 135

“ Swing Motor and Swing Gear - Check“ 136

Every 2000 Service Hours

“ Coolant System - Flush“ 115

“ Fuel Injection Pump - Clean“ 123

“ Fuel Injection Timing - Check“ 123

Every 3 Years After Date of Installation or Every 5 Years After Date of Manufacture

“ Seat Belt - Replace“ 133

i07746330

Battery - Recycle

SMCS Code: 1401-561

Always recycle a battery. Never discard a battery.

Always return used batteries to one of the following locations:

- A battery supplier
- An authorized battery collection facility
- Recycling facility

i04317049

Battery Electrolyte Level - Check

SMCS Code: 1401-535-FLV; 1401; 1401-535

WARNING

Personal injury may occur from failure to properly service the batteries.

Batteries give off flammable fumes that can explode. Electrolyte is an acid and can cause personal injury if it contacts the skin or eyes.

Prevent sparks near the batteries. Sparks could cause vapors to explode. Do not allow jumper cable ends to contact each other or the engine. Improper jumper cable connections can cause an explosion.

Always wear protective glasses when working with batteries.



Illustration 142

g02476476

Battery (1) is located in the engine compartment, beneath the floor plate. Have the battery checked at regular intervals to make sure that the electrolyte level is between the "MIN" and "MAX" marks.

Checking the battery requires the battery to be removed from the machine. Consult your Cat dealer.

i00934872

Battery Hold-Down - Tighten

SMCS Code: 7257

Tighten the hold-downs for the battery in order to prevent the batteries from moving during machine operation.

i06881458

Battery or Battery Cable - Inspect/Replace

SMCS Code: 1401-040; 1401; 1401-510; 1401-561; 1402-510; 1402-040

WARNING

Personal injury may occur from failure to properly service the batteries.

Batteries give off flammable fumes that can explode. Electrolyte is an acid and can cause personal injury if it contacts the skin or eyes.

Prevent sparks near the batteries. Sparks could cause vapors to explode. Do not allow jumper cable ends to contact each other or the engine. Improper jumper cable connections can cause an explosion.

Always wear protective glasses when working with batteries.

1. Turn the engine start switch to the OFF position. Remove the engine start switch key from the switch. Turn all switches to the OFF position.
2. Remove the battery hold-down.
3. Disconnect the negative battery cable at the battery.
4. Disconnect the positive battery cable at the battery.
5. Inspect the battery terminals for corrosion. Clean the battery terminals and the surfaces of the batteries with a clean cloth.
6. Inspect the battery cables for wear or damage.
7. For necessary repairs, consult your Cat dealer. Replace the cable or the battery, as needed.
8. Connect the positive battery cable at the battery.
9. Connect the negative battery cable at the battery.

10. Coat the battery terminals with petroleum jelly to prevent corrosion.
11. Reinstall the battery hold-down. Tighten the hold-downs for the battery to prevent the batteries from moving during machine operation.
12. Install the engine start switch key.

Checking the Battery Electrolyte Level

WARNING

Personal injury may occur from failure to properly service the batteries.

Batteries give off flammable fumes that can explode. Electrolyte is an acid and can cause personal injury if it contacts the skin or eyes.

Prevent sparks near the batteries. Sparks could cause vapors to explode. Do not allow jumper cable ends to contact each other or the engine. Improper jumper cable connections can cause an explosion.

Always wear protective glasses when working with batteries.



Illustration 143

g02722192

Battery (1) is located in the engine compartment, on the right side of the radiator. Have the battery checked at regular intervals to make sure that the electrolyte level is between the “MIN” and “MAX” marks.

Checking the battery requires the battery to be removed from the machine. Consult your Cat dealer.

Checking the Battery Gas Drainage Hose

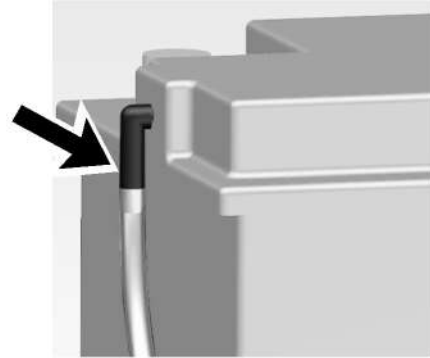

Illustration 144

g06152008

Check the battery gas drainage hose for proper venting.

Check to make sure that the battery gas drainage hose is not kinked or clogged.

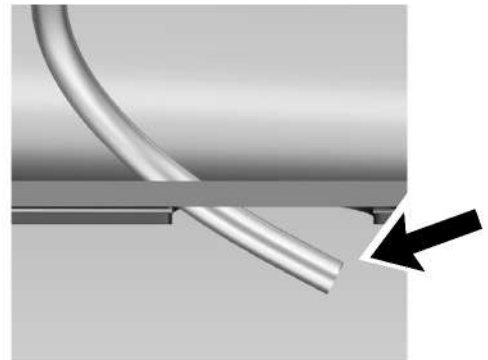

Illustration 145

g06152011

Check that the end of the battery gas drainage hose is not obstructed.

If the battery drainage hose is damaged, consult your Cat dealer.

Battery Recycle

Always recycle a battery. Never discard a battery.

Always return used batteries to one of the following locations:

- A battery supplier
- An authorized battery collection facility

- Recycling facility

i04551573

Belt - Inspect

SMCS Code: 1357-040; 1397-040

NOTICE

The V-belt must be tensioned correctly. Failure to tension the belt properly could damage the belt and/or to the belt guide, or water pump bearing.

Do not allow the belt to come in contact with any foreign substance such as oil or grease as damage to the V-belt may occur.

For maximum engine performance and maximum utilization of your engine, inspect the belts for wear and for cracking. Check the belt tension. Adjust the belt tension in order to minimize belt slippage. Belt slippage will decrease the belt life. Belt slippage will also cause poor performance of the alternator and of any driven equipment.

If new belts are installed, recheck the belt adjustment after 5 minutes of operation. If two belts or more are required for an application, replace the belts in belt sets. If only one belt of a pair is replaced, the new belt will carry more load. This is because the older belts are stretched. The additional load on the new belt could cause the new belt to break.

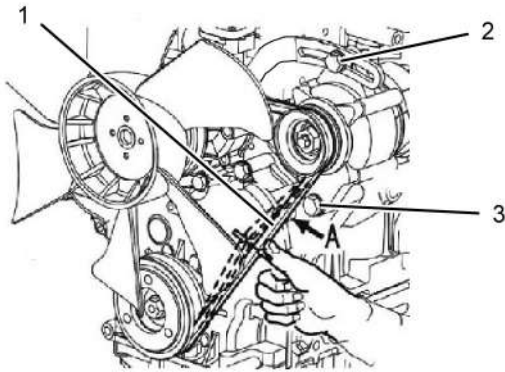

Illustration 146

g02460819

1. Open the engine cover.
2. Apply approximately 100 N (22 lb) of force midway between the pulleys.
3. Measure the deflection of the belt. The belt should deflect 6 to 8 mm (4/16 to 5/16 inch).
4. If the deflection is not correct, loosen alternator mounting bolt (3) and adjusting bolt (2). Move the alternator forward and backward in order to adjust belt (1) to the specified tension.

5. When the adjustment is correct, tighten adjusting bolt (2) and mounting bolt (3) securely.
6. Check the deflection of the belt again.
7. Close the engine cover.

Note: If a new belt is installed, check the belt adjustment again after 5 minutes of engine operation at the rated engine speed.

i04291969

Blade Linkage - Lubricate

SMCS Code: 6060-086

Dozer

Lower all the work tools and the blade to the ground.

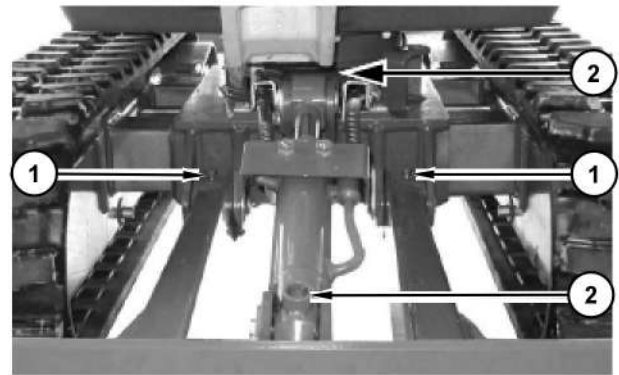

Illustration 147

g02458382

Wipe all fittings before lubricating.

1. Apply lubricant to the fittings for the arms (1) that support the blade.

2. Apply lubricant to the fittings of the blade cylinder (2).

i04294092

Boom, Stick and Bucket Linkage - Lubricate

SMCS Code: 6501-086; 6502-086; 6513-086



Illustration 148

g02460917

Wipe all fittings before you apply lubricant.

1. Park the machine on Level ground.
2. Lower the boom and work tool to the ground.
3. Lower the blade to the ground.
4. Stop the engine.
5. Remove the ignition key.
6. Cycle the joystick controls. Move the hydraulic lockout control to the RAISED position.
7. Apply lubricant to the grease fittings.

i04294421

Boom, Stick, and Frame - Inspect

SMCS Code: 6501; 6502; 6506

All earthmoving equipment is prone to a high degree of wear. Regular inspections for structural damage are necessary.

The interval between these inspections depends on the factors that follow.

- The age of the machine
- The severity of the application
- The loads that have been carried on the machine
- The amount of routine servicing that has been carried out

If the machine has been involved in any accident, the machine must be inspected thoroughly. Inspect the machine regardless of the date of the last inspection.

The machine must be clean before the machine is inspected.

Proper repair of frames and structures requires specific knowledge of the following subjects.

- Materials that have been used to manufacture the frame members
- Frame member construction
- Repair techniques that are recommended by the manufacturer.

Consult your Cat dealer if repairs are necessary. Your Cat dealer is qualified to carry out repairs on your behalf.

All repairs should be carried out by a Cat dealer. If you carry out your own repairs, contact your Cat dealer for advice about proper repair techniques.

Particular attention should be given to all welded structures. Inspect the following items thoroughly for cracks and for defects:

- Boom
- Stick
- Blade
- Lifting points
- Upper frame
- Lower frame

NOTICE

The areas highlighted are of particular importance but other areas must not be neglected. The entire structure must be carefully examined.

Boom

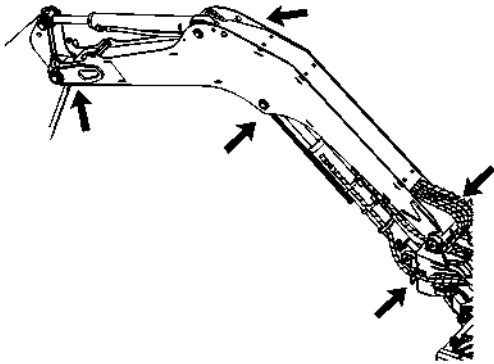

Illustration 149

g01425291

Check all welded joints and check the mounting points for the cylinder.

Blade

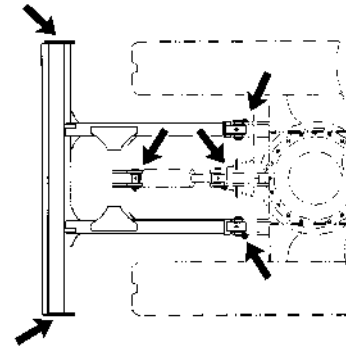

Illustration 151

g01425286

Check all welded joints and check the mounting points for the cylinder.

Stick

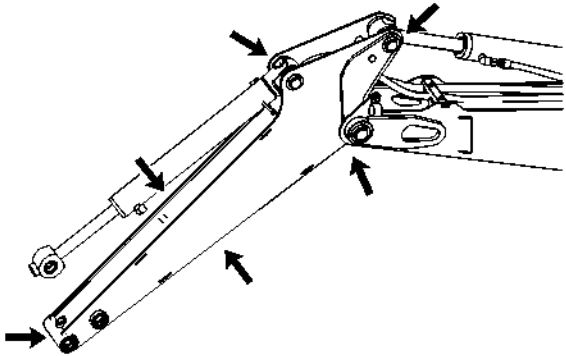

Illustration 150

g01425293

Check all welded joints and check the mounting points for the cylinder.

Lifting Points

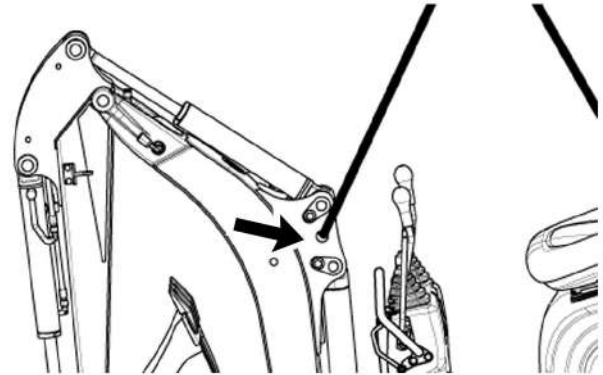

Illustration 152

g02461222

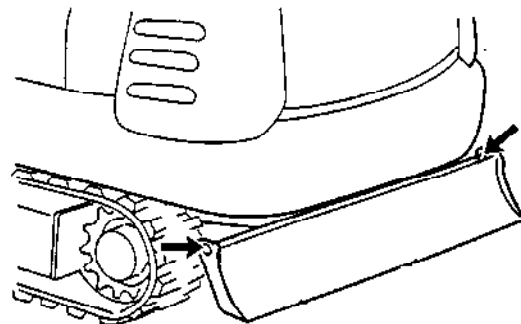

Illustration 153

g00309343

Check the approved lifting points carefully. Check the welds. Check that the plates are not excessively bent. Check that the lifting holes are not deformed.

Upper Frame

i04317011



Illustration 154

g02461696

Check for damaged panels. Specifically look for any damage to the polycarbonate shield (if equipped) or damage to the ROPS (if equipped) that might invalidate the certification. The ROPS (if equipped) and the polycarbonate shield (if equipped) are safety devices that must be maintained in good condition. Check for loose hardware or missing hardware.

Lower Frame

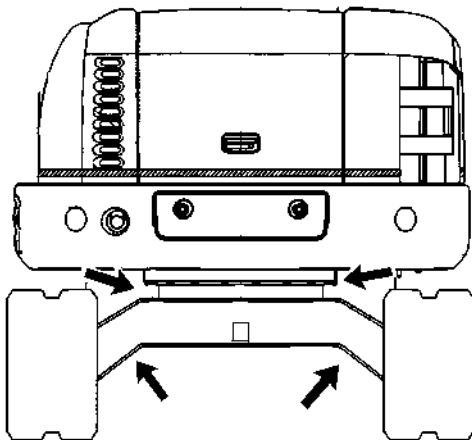

Illustration 155

g02461697

Check the weld joints in the lower structure. Check for loose hardware or missing hardware. Check the ring of bolts that secure the swing gear.

Bucket Tips - Inspect/Replace

SMCS Code: 6805-510; 6805-040

WARNING

Personal injury or death can result from bucket falling.

Block the bucket before changing bucket tips or side cutters.

Bucket Tips

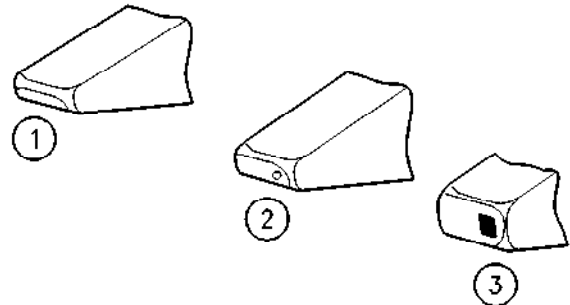

Illustration 156

g00101352

- (1) Usable
- (2) Replace this bucket tip.
- (3) Overworn

Check the bucket tips for wear. Consult your Cat dealer if the bucket tips need to be replaced. Your Cat dealer is qualified to carry out repairs on your behalf.

i04317357

Coolant System - Flush

SMCS Code: 1350; 1352; 1395

NOTICE

Care must be taken to ensure that fluids are contained during performance of inspection, maintenance, testing, adjusting, and repair of the product. Be prepared to collect the fluid with suitable containers before opening any compartment or disassembling any component containing fluids.

Refer to Special Publication, PERJ1017, "Dealer Service Tool Catalog" for tools and supplies suitable to collect and contain fluids on Cat® products.

Dispose of all fluids according to local regulations and mandates.

Note: During the warranty period, this procedure may be performed by Cat dealers only.

Refer to Operation and Maintenance Manual, "Cooling System Coolant - Change" for information on draining and filling the cooling system.

Note: Refer to Operation and Maintenance Manual, "General Hazard Information" that pertains to containing fluid spillage.

1. Flush the system with clean water in order to remove any debris.
2. Use a cooling system cleaner to clean the system. Follow the instructions on the label.
3. Drain the cleaner into a suitable container. Flush the cooling system with clean water.
4. Fill the cooling system with clean water and operate the engine until warm.

NOTICE

Improper or incomplete rinsing of the cooling system can result in damage to copper and other metal components.

To avoid damage to the cooling system, make sure to completely flush the cooling system with clear water. Continue to flush the system until all signs of the cleaning agent are gone.

5. Drain the cooling system into a suitable container and flush the cooling system with clean water.

Note: Flush the cooling system cleaner thoroughly from the cooling system. Cooling system cleaner that is left in the system will contaminate the coolant. The cleaner may also corrode the cooling system.

6. Repeat Steps 4 and 5 until the system is clean.
7. Fill the cooling system with coolant.

i05601975

Cooling System Coolant - Change

SMCS Code: 1350-044; 1352; 1395-044; 1395

 **WARNING**

Pressurized system: Hot coolant can cause serious burn. To open cap, stop engine, wait until radiator is cool. Then loosen cap slowly to relieve the pressure.

 **WARNING**

Personal injury can result from hot coolant, steam and alkali.

At operating temperature, engine coolant is hot and under pressure. The radiator and all lines to heaters or the engine contain hot coolant or steam. Any contact can cause severe burns.

Remove cooling system pressure cap slowly to relieve pressure only when engine is stopped and cooling system pressure cap is cool enough to touch with your bare hand.

Do not attempt to tighten hose connections when the coolant is hot, the hose can come off causing burns.

Cooling System Coolant Additive contains alkali. Avoid contact with skin and eyes.

NOTICE

Do not change the coolant until you read and understand the cooling system information in Special Publication, SEBU6250, "Caterpillar Machine Fluids Recommendations".

Failure to do so could result in damage to the cooling system components.

NOTICE

"ASTM D4985" coolant may not be mixed with any other coolants. Do not add any extender.

Mix the coolant with distilled water at the rate of 1/1. Ordinary water is not suitable. The use of more distilled water/coolant as well as the use of pure distilled water/coolant is not allowed.

Improper mixing could result in damage to cooling system/engine components.

NOTICE

Mixing ELC with other products will reduce the effectiveness of the coolant.

This could result in damage to cooling system components.

If Caterpillar products are not available and commercial products must be used, make sure they have passed the Caterpillar EC-1 specification for pre-mixed or concentrate coolants and Caterpillar Extender.

Note: During the warranty period, this procedure may be performed by Cat dealers only.

Machines

S/N: LJM1-01249; LJ21-00199
are shipped from the factory with coolant that fulfills "ASTM D4985". Coolant that fulfills "ASTM D4985" is required when you are changing the coolant.

Machines

S/N: LJM01250-Up; LJ200200-Up
are shipped from the factory with Cat Extended Life Coolant.

If the coolant in the machine is changed to Extended Life Coolant from another type of coolant, see Special Publication, SEBU6250, "Caterpillar Machine Fluids Recommendations".

1. Open the engine cover.

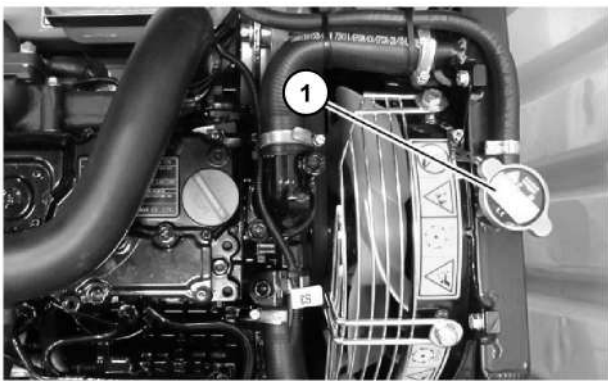

Illustration 157

g02461716

2. Loosen the radiator cap (1) slowly in order to release pressure. Remove the radiator cap.



Illustration 158

g02461717

3. Remove bolts (2) in order to remove the bumper.

Note: Refer to Operation and Maintenance Manual, "General Hazard Information" for information that pertains to containing fluid spillage.

4. Remove the drain plug and allow the coolant to drain into a suitable container.

Note: Dispose of drained fluids according to local regulations.

5. Flush the cooling system with clean water until the draining water is clean.
6. Install the drain plug.
7. Install the bumper and tighten the bolts to 180 N·m (132 lb ft).
8. Fill with the appropriate coolant mixture. See Operation and Maintenance Manual, "Capacities (Refill)".
9. Start the engine. Operate the engine without the radiator cap until the thermostat opens and the coolant level stabilizes.
10. Check the coolant reservoir. Maintain the coolant level between the "FULL" mark and the "LOW" mark.



Illustration 159

g02461718

11. If additional coolant is necessary, remove the coolant filler cap (3) and add the appropriate coolant mixture. Install the filler cap.
12. Install radiator cap (1).
13. Stop the engine.
14. Close the engine cover.

i04295109

Cooling System Coolant Level - Check

SMCS Code: 1350-535-FLV; 1350-040; 1395-535-FLV

WARNING

Pressurized system: Hot coolant can cause serious burn. To open cap, stop engine, wait until radiator is cool. Then loosen cap slowly to relieve the pressure.

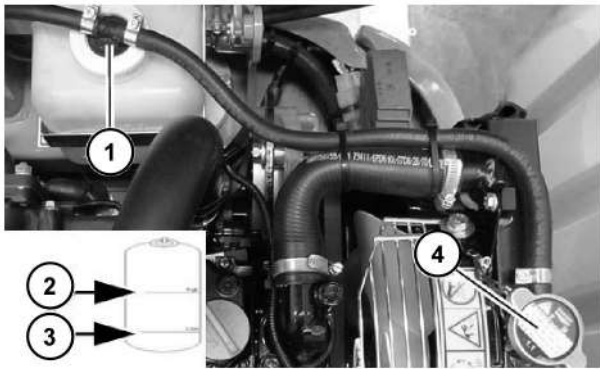

Illustration 160

g02461736

1. Open the engine cover.
 2. Maintain the coolant level between the "FULL" mark (2) on the coolant reservoir and the "LOW" mark (3) on the coolant reservoir.
- Note:** Refer to Operation and Maintenance Manual, "General Hazard Information" for information on Containing Fluid Spillage.
3. If additional coolant is necessary, remove the coolant filler cap (1) and add the appropriate coolant mixture. Install the filler cap.
 4. If the coolant reservoir is empty, remove the cooling system pressure cap (4) slowly in order to relieve pressure. Add coolant to the radiator.

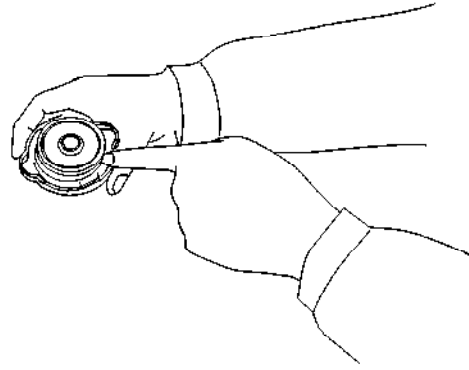

Illustration 161

g00102170

5. Inspect the condition of the cap gasket. If necessary, replace the cap.
6. Install the cooling system pressure cap.
7. Close the engine cover.

i04935110

Engine Air Filter Primary and/or Secondary Element - Replace

SMCS Code: 1054-510-PY; 1054-510-SE

NOTICE

Service the air cleaner only when the engine stopped. Engine damage could result.

NOTICE

Do not clean the air filter elements by bumping or tapping. Damage to the filter could result. Do not use elements with damaged pleats, gaskets, or seals. Damaged elements will allow dirt to pass through. Engine damage could result.

The air filter elements should be replaced immediately if the elements are damaged.

Note: Replace the air filter elements if "SERVICE" (red mark) is shown on the service indicator.

1. Open the engine cover.

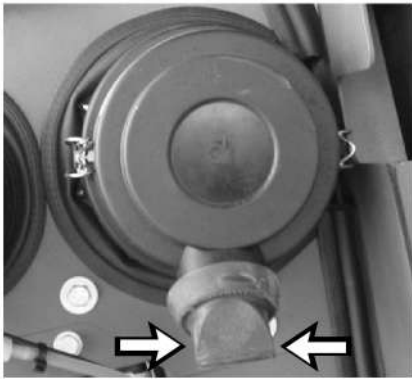

Illustration 162

g02461758

2. Squeeze the outlet tube slightly into a container in order to purge the dirt from the outlet tube.



Illustration 163

g02461759

3. Unclamp the access cover and remove the access cover to the air cleaner.

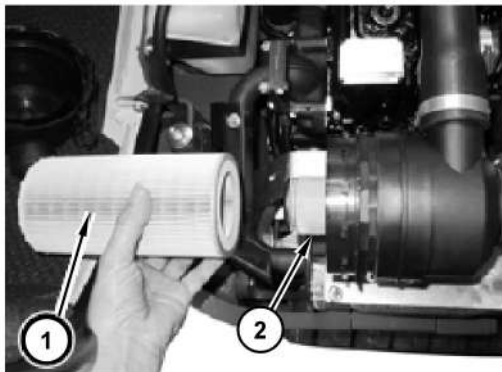

Illustration 164

g02461760

4. Remove both filter elements (1) and (2) from the air cleaner housing.

5. Cover the air inlet port in order to prevent dirt from getting inside the engine.
6. Inspect the filter elements. If the pleats, the gaskets or the seals are damaged, discard the filter element. Replace a damaged filter element with a new filter element.
7. Wipe dust from the interior of the air cleaner housing. Remove the cover from the air inlet port.
8. Put the clean air filter elements into the air cleaner housing and push the air filter elements into position.
9. Install the access cover and clamp the access cover.

Note: When installing the access cover, make sure that the outlet tube points downward.

10. Close the engine cover.

i04289171

Engine Air Filter Service Indicator - Inspect

SMCS Code: 7452-040-DJ

NOTICE

Service the air cleaner only with the engine stopped. Engine damage could result if the air cleaner is serviced while the engine is running.

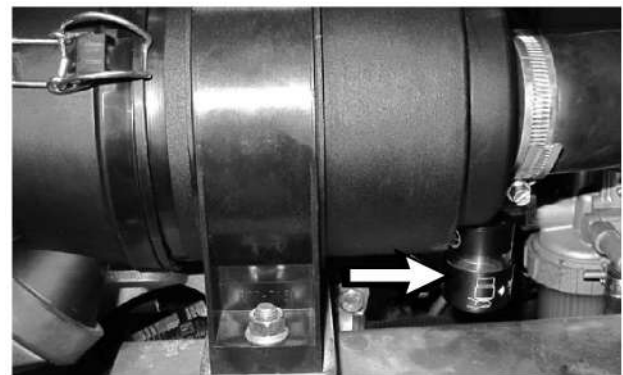

Illustration 165

g02455996

1. Open the engine cover.
2. Start the engine.
3. Run the engine at high idle.
4. If the piston in the engine air filter service indicator enters the red zone, service the air cleaner.
5. Stop the engine.

Note: See the Operation and Maintenance Manual, "Engine Air Filter Element - Replace".

i04289169

6. Close the engine cover.

i04295149

Engine Oil Level - Check

SMCS Code: 1000-535

WARNING

Hot oil and hot components can cause personal injury. Do not allow hot oil or hot components to contact skin.

NOTICE

Do not overfill the crankcase. Engine damage can result.

1. Open the engine cover.

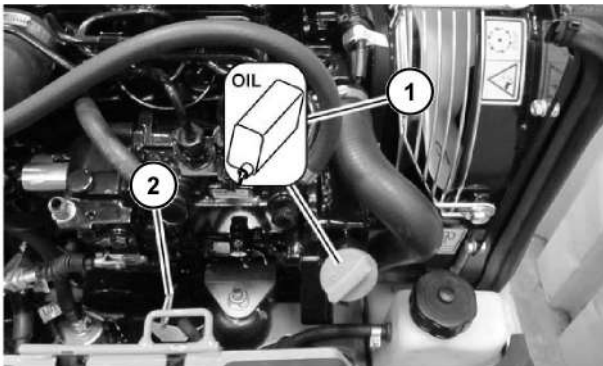

Illustration 166

g02461766

2. While the engine is stopped, maintain the oil level in the crosshatched area on the dipstick (2).
3. If necessary, remove the oil filler cap (1) and add oil. Allow the oil to drain into the crankcase before you check the oil level.
4. Close the engine cover.

Engine Oil Sample - Obtain

SMCS Code: 1000-008; 1000; 1348-008; 1348-554-SM; 7542-008; 7542-554-SM; 7542-554-OC

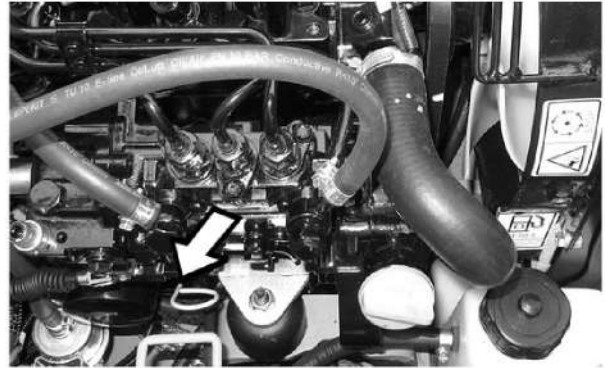

Illustration 167

g02455976

Obtain a sample of the engine oil through the dipstick tube. Refer to Special Publication, SEBU6250, "Caterpillar Machine Fluids Recommendations" "S·O·S Oil Analysis" for information that pertains to obtaining a sample of the engine oil. Refer to Special Publication, PEHP6001, "How To Take A Good Oil Sample" for more information about obtaining a sample of the engine oil.

i04935084

Engine Oil and Filter - Change

SMCS Code: 1318-510

WARNING

Hot oil and hot components can cause personal injury. Do not allow hot oil or hot components to contact skin.

NOTICE

Do not overfill the crankcase. Engine damage can result.

Note: During the warranty period, this procedure may be performed by Cat dealers only.

Change the oil while the machine is parked on flat ground. Lower all attachments to the ground.

1. Open the engine cover.

Note: Refer to Operation and Maintenance Manual, "General Hazard Information" for information on Containing Fluid Spillage.

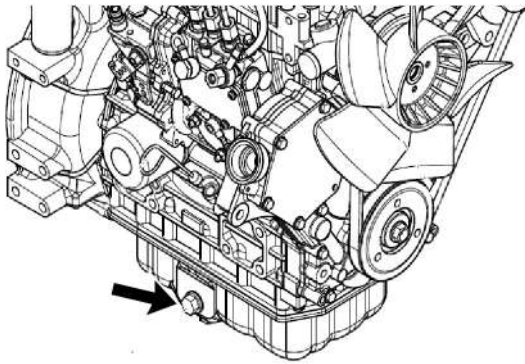

Illustration 168

g02461772

2. Remove the crankcase drain plug and allow the oil to drain into a suitable container. After you drain the oil, clean the drain plug and clean the plug hole. Inspect the seal for damage. If damaged, replace the seal. Install the drain plug.

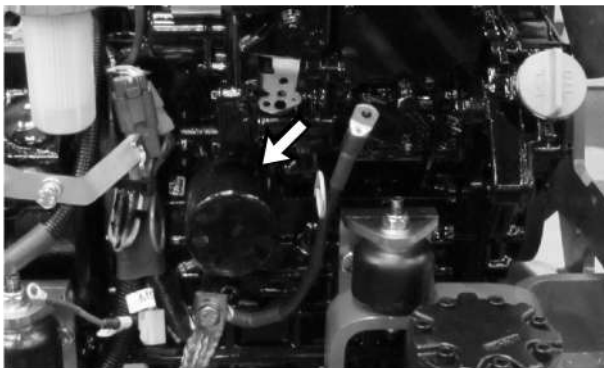

Illustration 169

g02461773

3. Remove the filter element with a filter wrench.
4. Install the new filter element by hand. When the gasket contacts the filter base, tighten the filter for an additional three quarters of a turn.

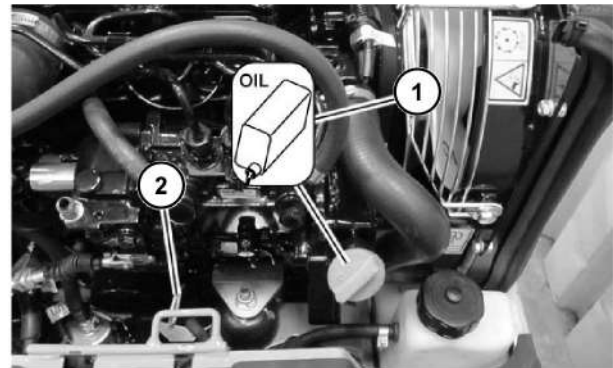

Illustration 170

g02461766

5. Remove the oil filler cap (1) and add the appropriate amount of oil. Allow the oil to drain into the crankcase before starting the engine.
6. Start the engine and operate the engine at low idle for several minutes. While the engine is running, check the filter base for oil leaks.
7. Stop the engine and allow the oil to drain back into the crankcase. Maintain the oil level in the crosshatched area on the dipstick (2).
8. Close the engine cover.

i04431975

Engine Valve Lash - Check/ Adjust

SMCS Code: 1102-025; 1102-535; 1105-025; 1105-535

Note: During the warranty period, this procedure may be performed by Cat dealers only.

Refer to the Service Manual for the complete procedure for checking the engine valve lash.

Note: Make sure that a qualified mechanic works on the engine. Special tools and training are required.

i04319613

i07681009

Fasteners - Check

SMCS Code: 7553-535**NOTICE**

Be careful never to mix metric with U. S. customary (standard) fasteners. Mismatched or incorrect fasteners causes machine damage or malfunction and can result in personal injury.

Original fasteners removed from the machine should be saved for reassembly whenever possible. If new fasteners are needed, the new fasteners must be of the same size and grade as the ones that are being replaced.

Check all the fasteners on the machine for tightness. Tighten any loose fasteners.

Film (Product Identification) - Clean

SMCS Code: 7405-070; 7557-070

Illustration 171

g02174985

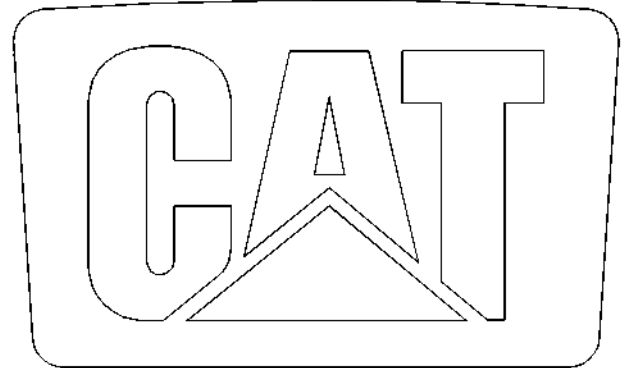
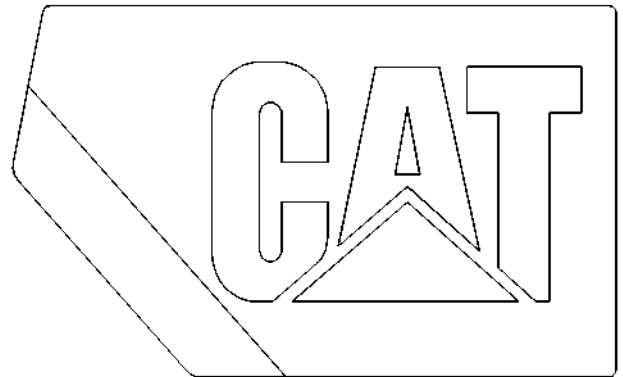

Illustration 172

g02175297



Illustration 173

g06394021

Typical example of the Product Identification Films.

Cleaning of the Films

Make sure that all of the product identification films are legible. Make sure that the recommended procedures are used in order to clean the product identification films. Ensure that all the product identification films are not damaged or missing. Clean the product identification films or replace the films.

Hand Washing

Use a wet solution with no abrasive material that contains no solvents and no alcohol. Use a wet solution with a "pH" value between 3 and 11. Use a soft brush, a rag, or a sponge in order to clean the product identification films. Avoid wearing down the surface of the product identification films with unnecessary scrubbing. Ensure that the surface of the product identification films is flushed with clean water and allow the product identification films to air dry.

Power Washing

Power washing or washing with pressure may be used in order to clean product identification films. However, aggressive washing can damage the product identification films.

Excessive pressure during power washing can damage the product identification films by forcing water underneath the product identification films. Water lessens the adhesion of the product identification film to the product, allowing the product identification film to lift or curl. These problems are magnified by wind. These problems are critical for the perforated film on windows.

To avoid lifting of the edge or other damage to the product identification films, follow these important steps:

- Use a spray nozzle with a wide spray pattern.
- A maximum pressure of 83 bar (1200 psi)
- A maximum water temperature of 50° C (120° F)
- Hold the nozzle perpendicular to the product identification film at a minimum distance of 305 mm (12 inch).
- Do not direct a stream of water at a sharp angle to the edge of the product identification film.

i07852323

Fuel Injection Pump - Clean

SMCS Code: 1251-070

Note: During the warranty period, this procedure may be performed by Cat dealers only.

Refer to the Service Manual for the complete procedure for cleaning the fuel injection pump or for adjusting the fuel injection pump.

Note: Make sure that a qualified mechanic works on the fuel injection pump. Special tools and training are required.

i07852325

Fuel Injection Timing - Check

SMCS Code: 1102-535; 1251-531; 1251-036-TM; 1251-535; 1290-535-TM; 1290-531-FT; 1290-531; 1290-036-TM

Note: During the warranty period, this procedure may be performed by Cat dealers only.

Refer to the Service Manual for the complete procedure for checking the injector fuel timing or for adjusting the injector fuel timing.

Note: Make sure that a qualified mechanic works on the injector fuel timing. Special tools and training are required.

Note: The correct fuel timing specification is given on the Engine Information Plate. Fuel timing specifications may differ for distinct engine applications and/or power ratings.

i04935071

Fuel System - Prime

SMCS Code: 1250-548

WARNING

Fuel leaked or spilled onto hot surfaces or electrical components can cause a fire. To help prevent possible injury, turn off the start switch and let the engine cool down when changing fuel filters or water separator elements. Clean up fuel spills immediately.

NOTICE

Care must be taken to ensure that fluids are contained during performance of inspection, maintenance, testing, adjusting, and repair of the product. Be prepared to collect the fluid with suitable containers before opening any compartment or disassembling any component containing fluids.

Refer to Special Publication, PERJ1017, "Dealer Service Tool Catalog" for tools and supplies suitable to collect and contain fluids on Cat® products.

Dispose of all fluids according to local regulations and mandates.

NOTICE

Do not loosen the fuel lines at the fuel manifold. The fittings may be damaged and/or a loss of priming pressure may occur when the fuel lines are loosened.

Prime the fuel system in order to fill the fuel filter, and prime the fuel system in order to purge trapped air. The fuel system should be primed under the following conditions:

- The fuel tank is running low.
- The machine has been stored.
- The fuel filter is being replaced.
- The fuel lines have been replaced.

1. Fill the fuel tank.
2. Turn the ignition key to the first position.
3. Wait 5 minutes while the fuel system primes automatically.

NOTICE

Do not crank the engine continuously for more than 30 seconds. Allow the starting motor to cool for two minutes before cranking the engine again.

4. Start the engine.
 5. Check the fuel system for leaks.
 6. Run the engine at low idle for 5 minutes.
- Note:** If the engine runs smoothly, and then stops, or the engine runs rough, more priming may be necessary.
7. If more priming is necessary, turn off the engine.
 8. Move the hydraulic lockout lever to the RAISED position.
 9. Turn the ignition key to the first position.
 10. Prime the fuel system again.

Note: If the fuel system does not prime correctly, consult your CAT dealer.

i04935066

Fuel System Filter - Replace

SMCS Code: 1261-510

WARNING

Personal injury or death may result from failure to adhere to the following procedures.

Fuel leaked or spilled onto hot surfaces or electrical components can cause a fire.

Clean up all leaked or spilled fuel. Do not smoke while working on the fuel system.

Disconnect the battery when changing fuel filters.

NOTICE

Do not fill the fuel filters with fuel before installing the fuel filters. The fuel will not be filtered and could be contaminated. Contaminated fuel will cause accelerated wear to fuel system parts.

Note: During the warranty period, this procedure may be performed by Cat dealers only.

1. Open the engine cover.

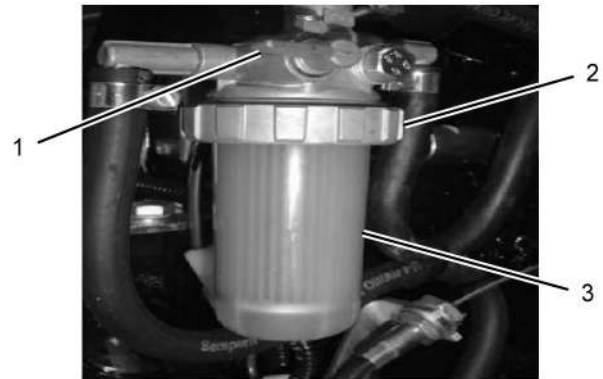

Illustration 174

g02464157

2. Turn off the fuel supply to the fuel filter by turning the shutoff valve (1) clockwise.

Note: Refer to Operation and Maintenance Manual, "General Hazard Information" that pertains to containing fluid spillage.

3. Remove collar (2) from the base of the filter housing.
4. Remove filter housing (3).
5. Discard the old filter.

6. Clean the filter housing.
7. Install a new filter into the filter housing.
8. Lubricate the O-ring seal with clean diesel fuel or lubricate the O-ring seal with motor oil.
9. Install the collar onto the base of the filter housing.
10. Turn on the fuel supply to the filter by turning the shutoff valve (1) counterclockwise.

Note: Do not start the engine until all service to the fuel system is complete. For instructions about priming the fuel system, refer to Operation and Maintenance Manual, "Fuel System - Prime".

11. Close the engine cover.

i04295189

Fuel System Water Separator - Drain

SMCS Code: 1263

WARNING

Personal injury or death may result from failure to adhere to the following procedures.

Fuel leaked or spilled onto hot surfaces or electrical components can cause a fire.

Clean up all leaked or spilled fuel. Do not smoke while working on the fuel system.

Disconnect the battery when changing the fuel filters.



Illustration 175

g02461837

The water separator is located on the right side of the machine behind the access panel.

1. Remove the access panel that is located on the right side of the machine.

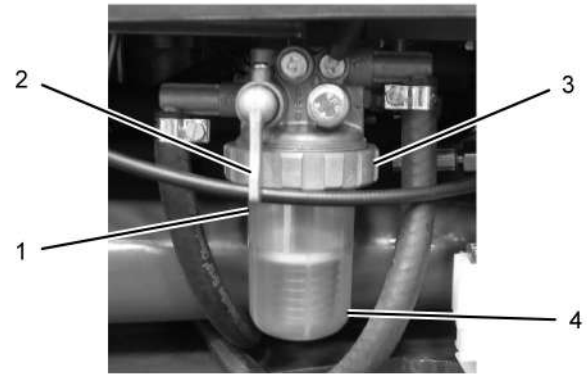

Illustration 176

g02461856

2. If the red indicator ring is at position (1), the collected water will need to be drained.
3. Move fuel shutoff lever (2) to the OFF position.

Note: Refer to Operation and Maintenance Manual, "General Hazard Information" for information that pertains to containing fluid spillage.

4. Unscrew retainer ring (3) and drain the water and the sediment into a suitable container.
5. Install the bowl. Make sure that the indicator is in position (4).

6. Turn the fuel shutoff lever to the ON position.

Note: Do not start the engine until all service to the fuel system is complete. For instructions about priming the fuel system, refer to Operation and Maintenance Manual, "Fuel System - Prime".

7. Install the access panel.

i04295209

i04295210

Fuel Tank Cap and Strainer - Clean

SMCS Code: 1273-070-STR

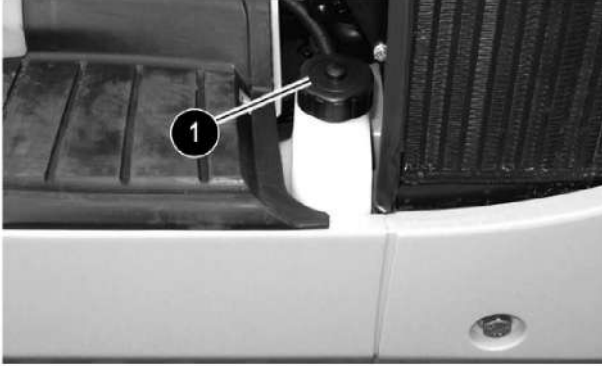

Illustration 177

g02461876

1. Open the engine cover.
2. Remove fuel cap (1).

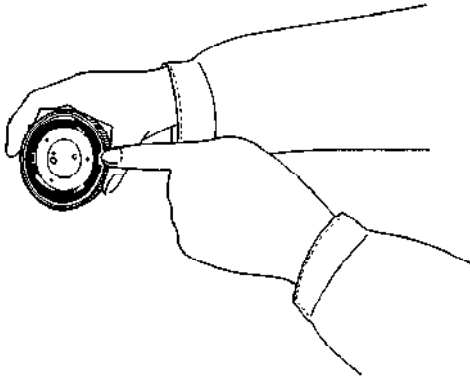

Illustration 178

g00104238

3. Inspect the cap. Replace the cap if the cap is damaged.
4. Remove the strainer that is located in the filler opening.
5. Wash the strainer and the fuel tank cap in a clean, nonflammable solvent.
6. Install the strainer into the filler opening.
7. Put a light coating of fuel on the cap gasket.
8. Install fuel cap (1).

Fuel Tank Water and Sediment - Drain

SMCS Code: 1273-543

Note: Refer to Operation and Maintenance Manual, "General Hazard Information" for information on Containing Fluid Spillage.

1. Open the engine cover and the fuel tank cap and pump out the fuel and sediment with a suitable pump. Allow the water and the sediment to drain into a suitable container.

Note: Discard the drained fluids according to local regulations.

2. Install the fuel tank cap and close the engine cover.

i05601310

Fuses - Replace

SMCS Code: 1417-510

Fuses – Fuses protect the electrical system from damage that is caused by overloaded circuits. Replace the fuse if the element separates. If the element of a new fuse separates, check the circuit. If necessary, consult your Cat dealer.

NOTICE

Always replace fuses with the same type and capacity fuse that was removed. Otherwise, electrical damage could result.

NOTICE

If it is necessary to replace fuses frequently, an electrical problem may exist.

Contact your Cat dealer.

The fuses are located on the right side of the machine below the operator stand, beneath the inspection opening.

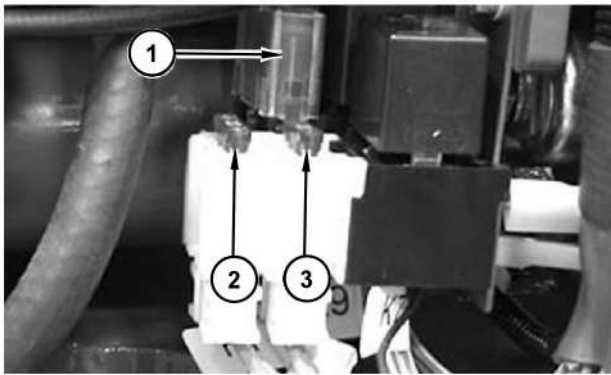

i02054663

Horn - Test

SMCS Code: 7402-081

Test the horn on a daily basis. Press downward on the horn button in order to sound the horn. If the horn does not sound, make the necessary repairs before you operate the machine.

i04935465

Illustration 179

g02455997

Side view inside storage compartment

(1) Main Fuse, (Atmospheric Pressure Sensor and Power Reduction Solenoid LJ21-Up) – 40 amp

(2) Relay, Display, and Cutoff Solenoid – 10 amp

(3) Horn and Working Light – 10 amp

Relays

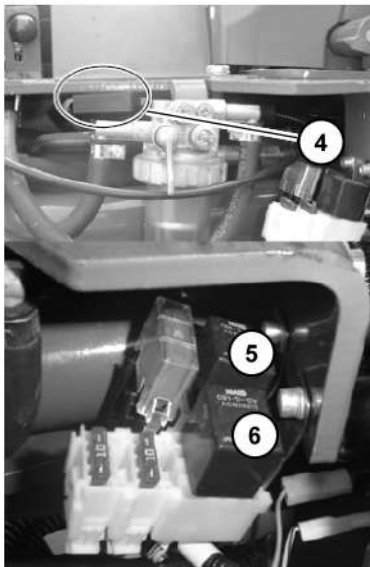

Illustration 180

g02456891

(4) Time Lag Cutoff Solenoid 1s – Relay

(5) Switching Cutoff Solenoid – Relay

(6) Starting – Relay

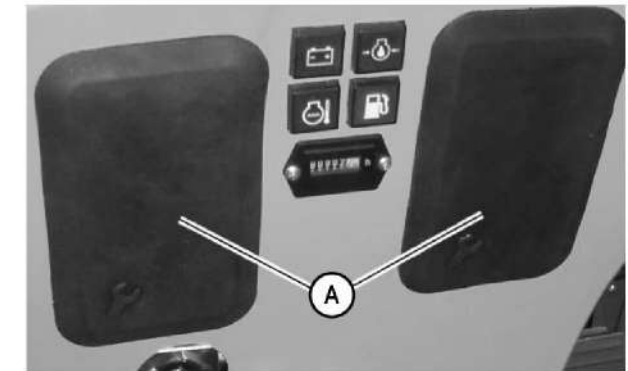

Illustration 181

g03109577

1. Flip one of the two covers (A) upwards.

i05600854

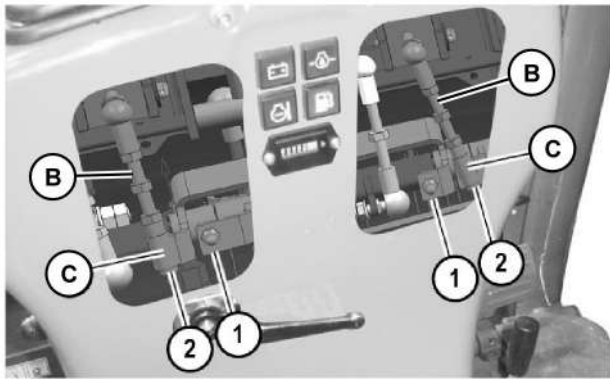

Illustration 182

g03109584

2. Push the self retaining bushing (C) on the rod linkage (B) upwards, in order to release the ball seat from the ball stud. Put grease into the ball seat.
3. Keep the self retaining bushing pushed back and move rod linkage (B) to either ball stud (1) or ball stud (2) and mount the ball seat to the ball stud.
4. Release the self retaining bushing and make sure that the ball seat is locked with the ball stud.
5. Put the cover (A) back in place.
6. Flip the second cover (A) upwards and repeat steps 2 to 5.

i04319614

Hydraulic System - Purge

SMCS Code: 5050-542

WARNING

Hot oil and hot components can cause personal injury. Do not allow hot oil or hot components to contact skin.

Note: Refer to Operation and Maintenance Manual, "General Hazard Information" for information on Containing Fluid Spillage.

Condensation can build up in the hydraulic tank and will need to be drained. Refer to Operation and Maintenance Manual, "Hydraulic System Oil - Change" for information on draining the hydraulic tank.

Open the drain valve and allow the oil and water mixture to drain into a suitable container. When no more water is seen coming from the drain valve, close the drain valve.

Hydraulic System Oil - Change

SMCS Code: 5056-044

WARNING

Hot oil and hot components can cause personal injury. Do not allow hot oil or hot components to contact skin.

NOTICE

If the machine is filled with non-biodegradable hydraulic oil and biodegradable hydraulic oil is wanting to be used, consult a Cat dealer. Biodegradable hydraulic oil can NOT be added to the system by performing an ordinary hydraulic oil change. Damage to the hydraulic system can occur.

Note: During the warranty period, this procedure may be performed by Cat dealers only.

1. Park the machine on level ground.

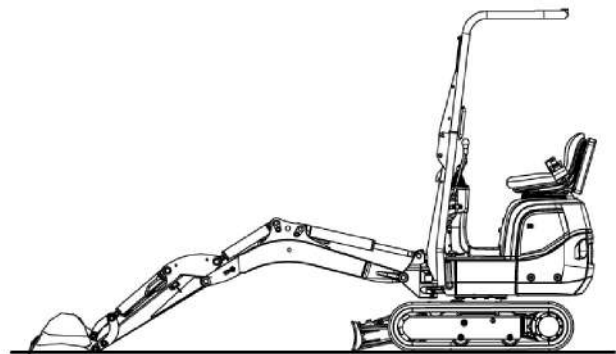

Illustration 183

g02461898

2. Extend the stick and the bucket fully. Lower the boom so that the bucket is rested on the ground. Lower the blade to the ground. Retract the extendable undercarriage (if equipped).
3. Turn the engine switch to the OFF position.
4. Cycle the joysticks in order to relieve any pressure remaining in the hydraulic lines.
5. Move the hydraulic lockout control lever to the RAISED position.
6. Open the engine cover.



Illustration 184

g02461897

7. Relieve the internal pressure in the hydraulic tank by slowly loosening the fill plug.

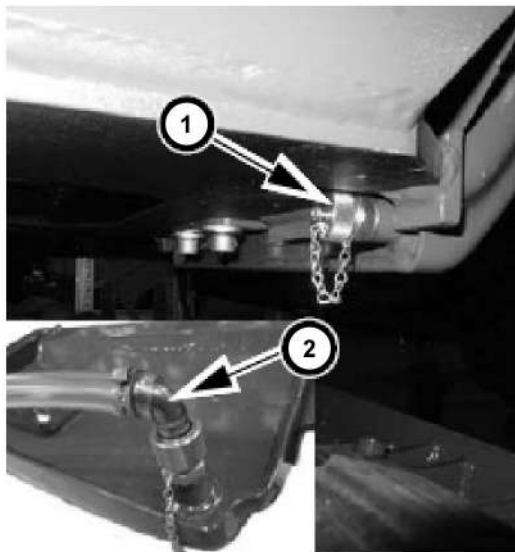

Illustration 185

g02463381

8. The hydraulic oil drain plug is located on the bottom of the hydraulic oil tank.

Note: Refer to Operation and Maintenance Manual, “General Hazard Information” for information on Containing Fluid Spillage.

9. Open drain valve (1) and attach drain hose (2). Allow the oil to drain into a suitable container.
10. Check the hydraulic tank for contamination and clean if necessary.
11. Remove the drain hose. Clean the drain valve and reinstall the plug.

12. Fill the hydraulic system oil tank with the same type of oil that was in it before. Refer to Operation and Maintenance Manual, “Lubricant Viscosities” and Operation and Maintenance Manual, “Capacities (Refill)”.
13. Inspect the gasket on the hydraulic tank filler plug for damage. Replace the gasket, if necessary.
14. Install the hydraulic tank filler plug.
15. Close the engine cover.
16. Start the engine and run the machine in order to bring the hydraulic oil to operating temperature. Operate the control levers in order to cause the hydraulic oil to flow through the circuits.

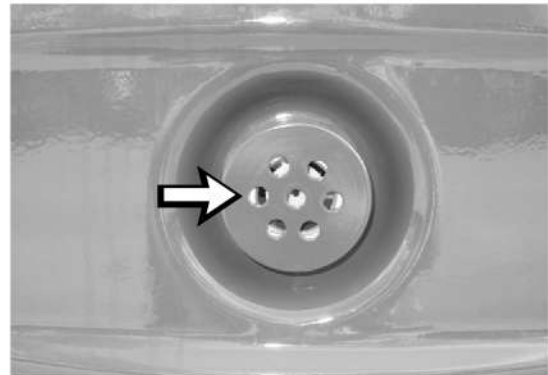

Illustration 186

g02461901

17. Maintain the hydraulic oil level in the middle of the sight gauge.

Note: The oil must be free of bubbles. If bubbles are present in the oil, air is entering the hydraulic system. Inspect the suction hoses, the hose clamps, and the hydraulic oil filter.

18. Stop the engine.
19. If necessary, tighten any loose clamps and any loose connections. Replace any damaged hoses.

i04935043

Hydraulic System Oil Filter (Return) - Replace

SMCS Code: 5068-510-RJ



WARNING

Hot oil and hot components can cause personal injury. Do not allow hot oil or hot components to contact skin.

Note: During the warranty period, this procedure may be performed by Cat dealers only.

1. Open the engine cover in order to gain access to the hydraulic oil tank. Clean the area thoroughly in order to prevent dirt from entering the filter.

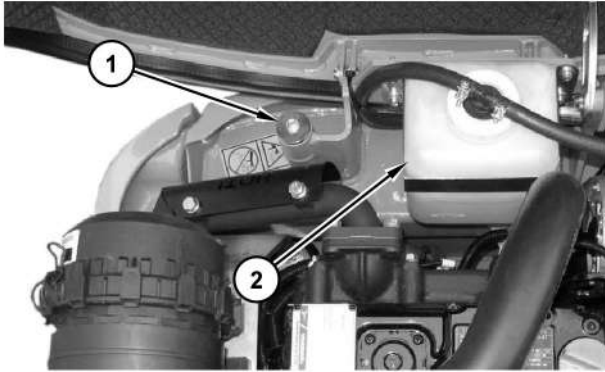

Illustration 187

g02466816

2. Slowly remove hydraulic oil filler plug (1) in order to relieve the pressure in the hydraulic oil tank.

Note: Refer to Operation and Maintenance Manual, "General Hazard Information" for information on Containing Fluid Spillage.

3. Remove coolant over flow tank (2).

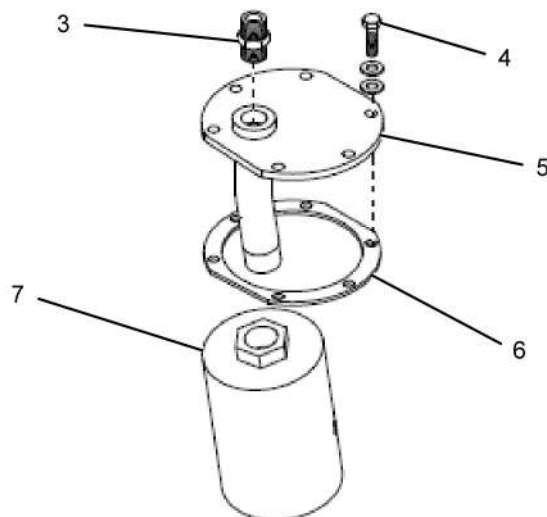

Illustration 188

g02463459

4. Remove fitting (3) from fill cap (5).
5. Remove bolts (4) from the cap (5).
6. Remove the filter assembly.

7. Remove the used filter (7).
8. Check seal (6) for damage. Replace the seal if damaged.
9. Install the new filter.
10. Reinstall the filter assembly in the reverse order.
11. Close the engine cover.

i05600764

Hydraulic System Oil Level - Check

SMCS Code: 5050-535

WARNING

Hot oil and hot components can cause personal injury. Do not allow hot oil or hot components to contact skin.

Note: Check the hydraulic system oil level with the machine on a level surface and when the hydraulic oil has reached operating temperature.

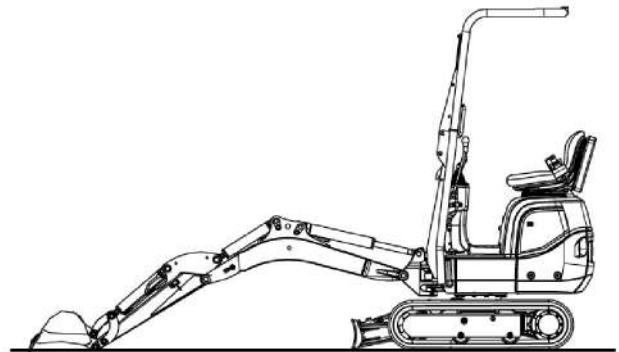

Illustration 189

g02461898

1. Extend the stick and the bucket fully. Lower the boom so that the bucket is rested on the ground. Lower the blade to the ground.

i04295230

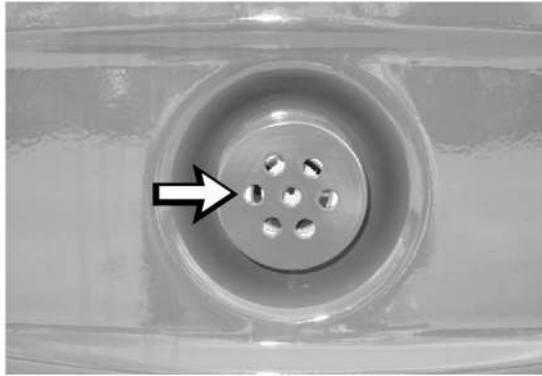

Illustration 190

g02461901

2. The sight gauge is located outside the hydraulic tank, at the rear of the machine.
3. Maintain the hydraulic system oil level in the middle of the sight gauge.
4. Open the engine cover.

NOTICE

Never remove the fill/vent plug from the hydraulic tank if the oil is hot.

Air can enter the system and cause pump damage.

5. Slowly loosen the filler plug in order to relieve any pressure and add hydraulic oil, if necessary.
6. Clean the filler plug. Install the filler plug.
7. Close the engine cover.

Hydraulic System Oil Sample - Obtain

SMCS Code: 5050-008-OC; 5095-008; 5095-SM; 7542; 7542-008



Illustration 191

g02461897

Obtain a sample of the hydraulic oil through the filler tube. Refer to Special Publication, SEBU6250, "S-O-S Oil Analysis" for information that pertains to obtaining a sample of the hydraulic oil. Refer to Special Publication, PEGJ0047, "How To Take A Good Oil Sample" for more information about obtaining a sample of the hydraulic oil.

i04319612

Light - Test

SMCS Code: 1429-081

If the machine is equipped with lights, turn on the switch. Observe the lights and replace any that are not working.

i04317069

Main Relief Valve - Check

SMCS Code: 5069-535

Consult your Cat dealer for service to the main valve.

i02106227

Oil Filter - Inspect

SMCS Code: 1308-507; 5068-507

Inspect a Used Filter for Debris

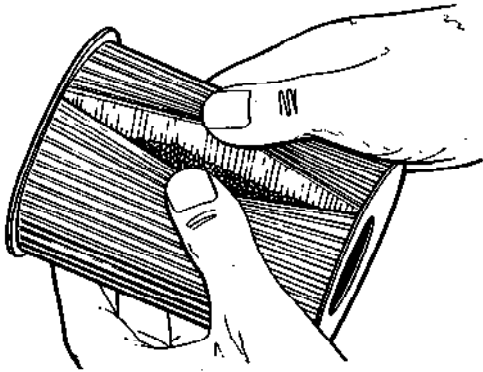

Illustration 192

g00100013

The element is shown with debris.

Use a filter cutter to cut the filter element open. Spread apart the pleats and inspect the element for metal and for other debris. An excessive amount of debris in the filter element can indicate a possible failure.

If metals are found in the filter element, a magnet can be used to differentiate between ferrous metals and nonferrous metals.

Ferrous metals can indicate wear on steel parts and on cast iron parts.

Nonferrous metals can indicate wear on the aluminum parts of the engine such as main bearings, rod bearings, or turbocharger bearings.

Small amounts of debris may be found in the filter element. This could be caused by friction and by normal wear. Consult your Caterpillar dealer in order to arrange for further analysis if an excessive amount of debris is found.

Using an oil filter element that is not recommended by Caterpillar can result in severe engine damage to engine bearings, to the crankshaft, and to other parts. This can result in larger particles in unfiltered oil. The particles could enter the lubricating system and the particles could cause damage.

i04289115

Radiator Core - Clean

SMCS Code: 1353-070



Illustration 193

g02455956

1. Open the engine cover.
2. You can use compressed air or water to remove dust and other debris from the radiator fins. The compressed air should be oil free and 200 kPa (29 psi) maximum.
3. Close the engine cover.

i05252972

Rollover Protective Structure (ROPS) - Inspect

SMCS Code: 7323-040; 7325-040

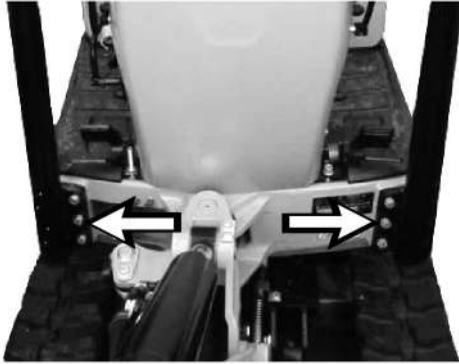

Illustration 194

g02455240

Inspect the Rollover Protection Structure (ROPS) for bolts that are loose, damaged, or missing. Replace any bolts that are loose, damaged, or missing with original replacement parts only. Torque the 6 M12 bolts to 120 N·m (88.5 lb ft).

Note: Apply thread lock to all bolt threads for the ROPS before you install the bolts.

Do not weld reinforcement plates to the ROPS in order to straighten the ROPS. Do not weld reinforcement plates to the ROPS in order to repair the ROPS.

Consult your Cat dealer for inspection of any potential damage or repair of any damage to any operator protective structure. (Including ROPS, FOPS, TOPS, OPS, and OPG) Refer to Special Instruction, SEHS6929, "Inspection, Maintenance, and Repair of Operator Protective Structures (OPS) and Attachment Installation Guidelines for All Earthmoving Machinery"

i04289114

Seat Belt - Inspect

SMCS Code: 7327-040

Always check the condition of the seat belt and the condition of the seat belt mounting hardware before you operate the machine. Replace any parts that are damaged or worn before you operate the machine.

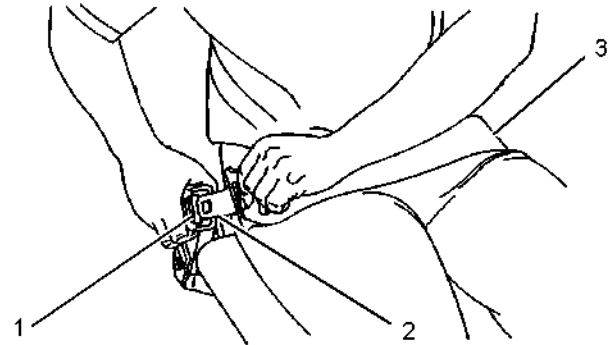

Illustration 195

g02477000

Typical example

Check the seat belt mounting hardware (1) for wear or for damage. Replace any mounting hardware that is worn or damaged. Make sure that the mounting bolts are tight.

Check buckle (2) for wear or for damage. If the buckle is worn or damaged, replace the seat belt.

Inspect the seat belt (3) for webbing that is worn or frayed. Replace the seat belt if the seat belt is worn or frayed.

Consult your Cat dealer for the replacement of the seat belt and the mounting hardware.

i06970675

Seat Belt - Replace

SMCS Code: 7327-510

The seat belt should be replaced within 3 years of the date of installation. A date of installation label is attached to the seat belt retractor and buckle. If the date of installation label is missing, replace the belt within 3 years from the year of manufacture as indicated on the belt webbing label, buckle housing, or installation tags (non-retractable belts).

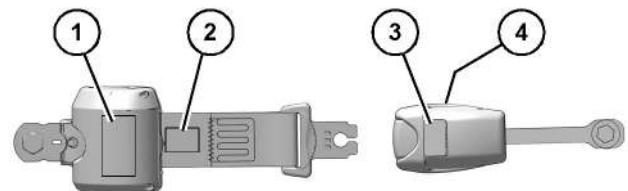

Illustration 196

g06183390

- (1) Date of installation (retractor)
- (2) Year of manufacture (tag) (fully extended web)
- (3) Date of installation (buckle)
- (4) Year of manufacture (underside) (buckle)

Consult your Cat dealer for the replacement of the seat belt and the mounting hardware.

Maintenance Section
Sound Suppression (Covers, Panels) - Inspect/Replace

Determine the age of a new seat belt before installing on seat. A manufacture label is on the belt webbing and imprinted on the belt buckle. Do not exceed the install by date on the label.

A complete seat belt system should be installed with new mounting hardware.

Date of installation labels should be marked and affixed to the seat belt retractor and buckle.

Note: Date of installation labels should be permanently marked by punch (retractable belt) or stamp (non-retractable belt).

If your machine is equipped with a seat belt extension, also perform this replacement procedure for the seat belt extension.

i04319615

Sound Suppression (Covers, Panels) - Inspect/Replace

SMCS Code: 1801-040; 1801-510; 7261-040; 7261-510

1. Open the engine cover.
2. Inspect the insulating mats for deterioration. Look for any insulating mats that may be missing. Replace any insulating mats that may be torn or missing.
3. Close the engine cover.

i05616603

Swing Bearing - Lubricate

SMCS Code: 7063-086

WARNING

Do not rotate the machine during lubrication. Danger of sever crushing that can cause severe injury or death.

1. Park the machine on a level surface. Lower all work tools to the ground. Place the hydraulic lockout control in the RAISED position.

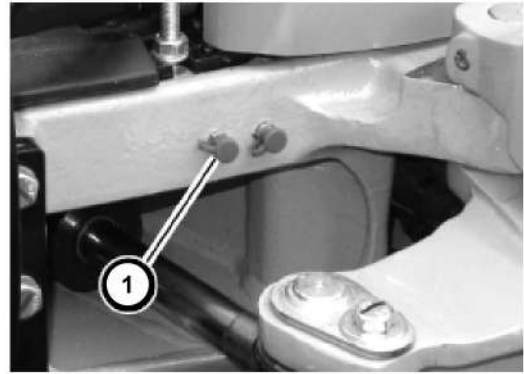

Illustration 197

g02462537

2. The fitting for the swing bearing is located under the boom base on the front side of the upper structure.
3. Wipe the fitting and lubricate the fitting.

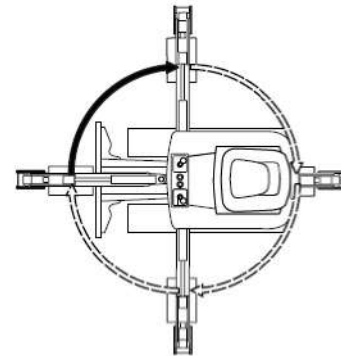

Illustration 198

g02462600

4. Rotate the upper structure for 90°.
5. Apply grease to the fittings for the swing bearing.
6. Repeat Step 4 and Step 5 until the upper structure has rotated 360°.
7. Rotate the upper structure 360° twice.

i04296123

Swing Frame and Cylinder Bearings - Lubricate

SMCS Code: 5105-086-BD; 6506-086-BD; 6507-086-BD

1. Park the machine on level surface. Lower all work tools to the ground.
2. Turn the engine switch to the OFF position.

3. Cycle the joysticks in order to relieve any pressure remaining in the hydraulic lines.
4. Place the hydraulic lockout control lever in the RAISED position.

i05600629

Swing Gear - Lubricate

SMCS Code: 7063-086

WARNING

Do not rotate the machine during lubrication. Danger of sever crushing that can cause severe injury or death.

1. Park the machine on a level surface. Lower all work tools to the ground. Place the hydraulic lockout control

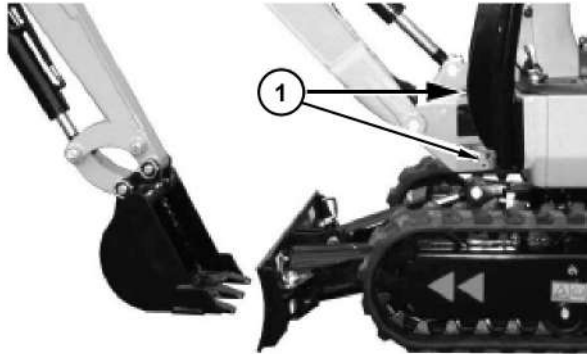

Illustration 199

g02462996

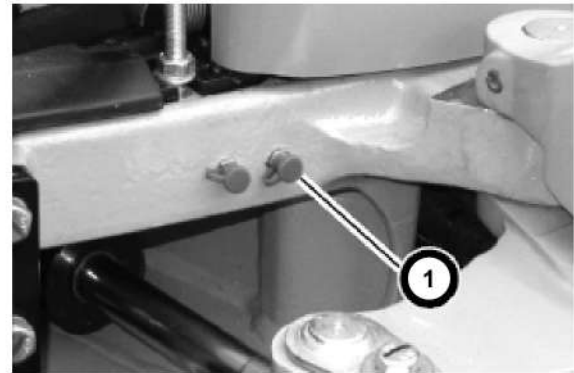

Illustration 201

g02462839

2. The fitting (1) for the swing gear is located under the boom base on the front side of the upper structure.
3. Wipe fitting (1) and lubricate the fitting.

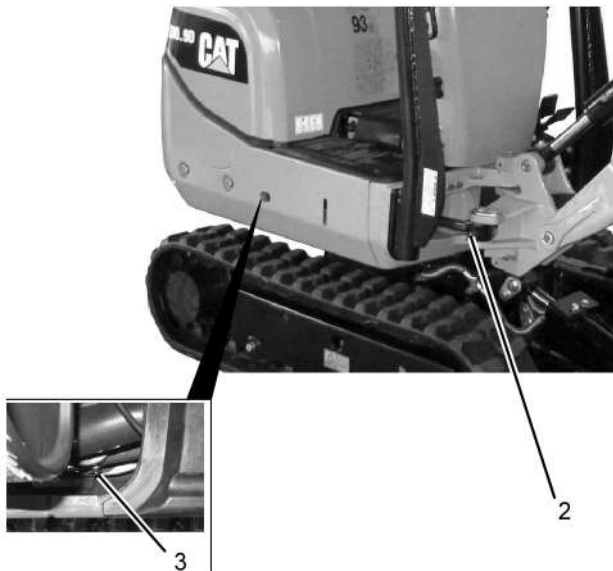

Illustration 200

g02462998

Open the engine cover in order to gain access to the head end of the swing cylinder.

5. Wipe the fittings before you lubricate the fittings.

Note: Keep the grease fittings clean and remove any remain grease.

6. Apply lubricant to the fittings (1), (2), and (3).

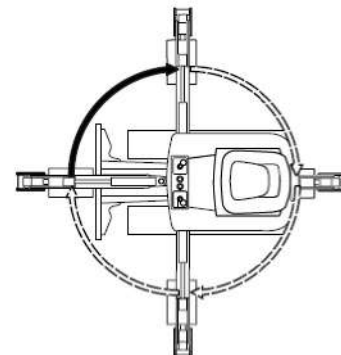

Illustration 202

g02462600

4. Rotate the upper structure for 90°.
5. Apply grease to the fittings for the swing gear.

6. Repeat Step 4 and Step 5 until the upper structure has rotated 360°.
7. Rotate the upper structure 360° twice.

i04319616

Swing Motor and Swing Gear - Check

SMCS Code: 7063-535; 79PA-535

Consult your Cat dealer for service to the swing gear and the swing motor.

i04288321

Track Adjustment - Adjust

SMCS Code: 4170-025

Tightening the Tracks

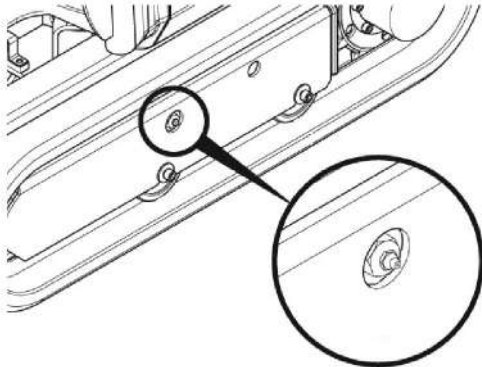

Illustration 203

g02455137

1. Wipe the fitting before you add grease.
2. Add grease through the valve fitting until the correct tension is reached.
3. Operate the track back and forth in order to equalize the pressure.
4. Check the amount of sag. Adjust the track, as needed. Refer to Operation and Maintenance, "Track Adjustment - Inspect".

5. Repeat the same procedure for the other track.

Loosening the Track

WARNING

Personal injury or death can result from grease under pressure.

Grease coming out of the relief valve under pressure can penetrate the body causing injury or death.

Do not watch the relief valve to see if grease is escaping. Watch the track or track adjustment cylinder to see if the track is being loosened.

Loosen the relief valve one turn only.

If track does not loosen, close the relief valve and contact your Caterpillar dealer.

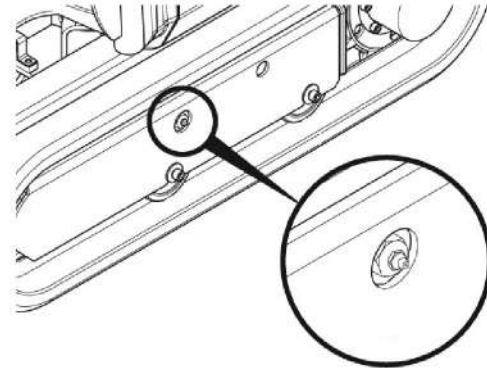

Illustration 204

g02455137

1. Loosen the filler valve carefully until the track begins to loosen. One turn should be the maximum.
2. Tighten the filler valve when the desired track tension is reached.
3. Operate the track back and forth in order to equalize pressure.
4. Check the amount of sag in the track. Adjust the track, as needed. Refer to Operation and Maintenance, "Track Adjustment - Inspect".
5. Repeat the same procedure for the other track.

If the correct adjustment cannot be achieved, consult your Cat dealer.

i04288309

Track Adjustment - Inspect

SMCS Code: 4170-040

Note: Keeping the track properly adjusted will increase the service life of the track components and the drive components.

Check the rubber tracks for the following conditions:

- Steel cords that are cut
- Core irons that are fractured
- Rubber flaking off to the point of showing steel cords or core irons
- Loss of traction or grousers are worn down to approximately 5 mm (0.2 inch) in height.

If any of the above conditions or a combination of the above conditions are observed, replace the track.

Measuring Rubber Track Tension

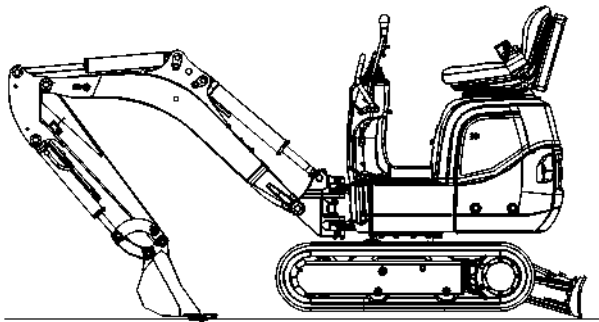

Illustration 205

g02476456

1. Park the machine on a level surface.
2. Place the blade at the rear of the machine.
3. Lower the bucket to the ground with the stick in a vertical position.
4. Apply boom down pressure and at the same time lift the machine with the blade until the tracks have cleared the ground.
5. Place the machine in a horizontal position.
6. Clean the track rollers and the area around the skid plate.

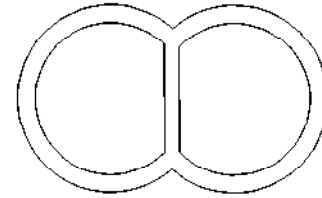

Illustration 206

g00484245

7. For a machine that is equipped with the rubber tracks, locate the "omega" mark on the inside flat of the track.
8. Locate the "omega" mark under the center track roller.

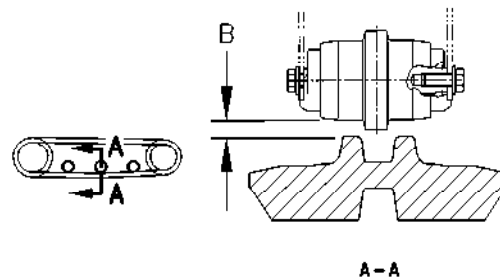

Illustration 207

g00522663

The distance (B) should be 15 to 20 mm (0.6 to 0.8 inch).

9. Measure the sag in the track. The sag is measured from the bottom of the roller to the surface on the top of the track. A properly adjusted track will have 15 to 20 mm (0.6 to 0.8 inch) of sag.

i04288250

Travel Alarm - Test

SMCS Code: 7429-081

Move the machine in order to test the travel alarm.

1. Start the engine. Lower the hydraulic lockout control to the UNLOCKED position.
2. Raise the work tool. Make sure that there is adequate overhead clearance.

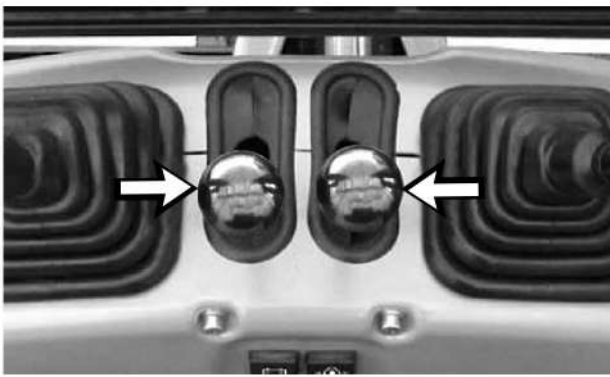

Illustration 208

g02455076

3. Use the travel levers to move the machine forward. The travel alarm should sound.
4. Release the travel levers in order to stop the machine.
5. Use the travel levers to move the machine backward. The travel alarm should sound.
6. Release the travel levers in order to stop the machine. Lower the work tool to the ground. Deactivate the hydraulic control and drive levers by placing the hydraulic lockout control in the RAISED position. Stop the engine.

i04288151

Undercarriage - Check

SMCS Code: 4150-535

1. Check the track rollers and the idler wheels for possible leakage.
2. Check the surface of the track, the track rollers, the idler wheels, and the drive sprockets. Look for signs of wear and loose mounting bolts.
3. Listen for any abnormal noises while you are moving slowly in an open area.
4. If abnormal wear exists or abnormal noises or leaks are found, consult your Cat dealer.

i04319623

Undercarriage - Inspect

SMCS Code: 4150-040

Inspect the bearing play of the tread rollers, track carrier rollers, and front idlers.

Consult your Cat dealer for service to the undercarriage components.

i04319618

Visual Inspection

SMCS Code: 7553-040

Perform a visual inspection of the alternator, starter, and electrical connections.

Check for cracks in the housings, loose, or frayed wires. Check for loose electrical connections. Check the alternator for bearing play.

Check the function of the preheating system. Check for loose electrical connections.

i04288189

Windows - Clean

SMCS Code: 7310-070; 7340-070

NOTICE

Wash polycarbonate windows with mild soap and water. Never use a cleaning solvent on polycarbonate windows. Never wipe dust in a dry state, as polycarbonate windows can be easily scratched.

Soap and Water

Use a clean sponge or a soft cloth. Wash the windows with a mild soap or with a mild detergent. Also use plenty of lukewarm water. Rinse the windows thoroughly. Dry the windows with a moist chamois or with a moist cellulose sponge.

Warranty Section

Warranty Information

i06044323

Emissions Warranty Information

SMCS Code: 1000

The certifying engine manufacturer warrants to the ultimate purchaser and each subsequent purchaser that:

1. New non-road diesel engines and stationary diesel engines less than 10 liters per cylinder (including Tier 1 and Tier 2 marine engines < 37 kW, but excluding locomotive and other marine engines) operated and serviced in the United States and Canada, including all parts of their emission control systems ("emission related components"), are:
 - a. Designed, built, and equipped so as to conform, at the time of sale, with applicable emission standards prescribed by the United States Environmental Protection Agency (EPA) by way of regulation.
 - b. Free from defects in materials and workmanship in emission-related components that can cause the engine to fail to conform to applicable emission standards for the warranty period.
2. New non-road diesel engines (including Tier 1 and Tier 2 marine propulsion engines < 37 kW and Tier 1 through Tier 4 marine auxiliary engines < 37 kW, but excluding locomotive and other marine engines) operated and serviced in the state of California, including all parts of their emission control systems ("emission related components"), are:
 - a. Designed, built, and equipped so as to conform, at the time of sale, to all applicable regulations adopted by the California Air Resources Board (ARB).
 - b. Free from defects in materials and workmanship which cause the failure of an emission-related component to be identical in all material respects to the component as described in the engine manufacturer's application for certification for the warranty period.

3. New non-road diesel engines installed in construction machines conforming to the South Korean regulations for construction machines manufactured after January 1, 2015, and operated and serviced in South Korea, including all parts of their emission control systems ("emission related components"), are:
 - a. Designed, built, and equipped so as to conform, at the time of sale, with applicable emission standards prescribed in the Enforcement Rule of the Clean Air Conservation Act promulgated by South Korea MOE.
 - b. Free from defects in materials and workmanship in emission-related components that can cause the engine to fail to conform to applicable emission standards for the warranty period.

The aftertreatment system can be expected to function properly for the lifetime of the engine (emissions durability period) subject to prescribed maintenance requirements being followed.

A detailed explanation of the Emission Control Warranty that is applicable to new non-road and stationary diesel engines, including the components covered and the warranty period, is found in a supplemental Special Publication. Consult your authorized Cat dealer to determine if your engine is subject to an Emission Control Warranty and to obtain a copy of the applicable Special Publication.

Reference Information Section

Reference Materials

i07422648

Reference Material

SMCS Code: 1000; 7000

Additional literature regarding your product may be purchased from your local Cat dealer or by visiting publications.cat.com. Use the product name, sales model, and serial number to obtain the correct information for your product.

publications.cat.com

i07743978

Decommissioning and Disposal

SMCS Code: 1000; 7000

When the product is removed from service, local regulations for the product decommissioning will vary. Disposal of the product will vary with local regulations.

Improperly disposing of waste can threaten the environment. Obey all local regulations for the decommissioning and disposal of materials.

Utilize appropriate personal protective equipment when decommissioning and disposing product.

Consult the nearest Cat dealer for additional information. Including information for component remanufacturing and recycling options.

i04935039

Caterpillar Approved Work Tools

SMCS Code: 6700; 7007

NOTICE

Use only work tools that are recommended by Caterpillar. The use of work tools that are not recommended by Caterpillar could damage your machine. Consult your Cat dealer for information on recommended work tools.

The following work tools have been approved by Caterpillar. Refer to the owner manual and the service manual for each work tool for proper operation, maintenance, and servicing of the work tools.

Using work tools of other manufactures, or work tools which have been released for other excavators, can reduce the machines output and stability considerably, and can also damage the machine and cause injuries to the operator or other personnel.

Always compare the weight of the work tool and its maximum payload with the indications in the lift capacity table. Never exceed the maximum payload stated in the lift capacity table.

Table 19

Caterpillar Approved Work Tools			
	Width	Weight	Capacity
Backhoe bucket	250 mm (10 inch)	15 kg (33 lb)	14 L (4 gal)
Backhoe bucket	370 mm (14.5 inch)	17 kg (38 lb)	18 L (5 gal)
Backhoe bucket	370 mm (14.5 inch)	19 kg (42 lb)	24 L (6.5 gal)
Bucket	700 mm (27.5)	25.5 kg (54 lb)	27 L (7 gal)
H25D Hammer		70 kg (154 lb)	

The use of hammers shortens the life of hydraulic oil. If a hammer is used, the following measures should be taken:

Table 20

Application		Hydraulic Oil	Hydraulic System Oil Filter
Normal Work (Excavation Work)		Replace the first time after 500 service hours, then every 1000 service hours	Replace the first time after 50 service hours, then every 500 service hours
Percentage of Hammer Work	20%	Every 800 service hours	300 service hours
	40%	Every 400 Service hours	
	60%	Every 300 service hours	100 service hours
	Over 80%	Every 200 service hours	

This list was completed at the time of publication. There may be additional work tools that have been approved since that time. Consult your Cat dealer for an updated list of approved work tools.

Index

A

Access Door and Cover Locations.....	98
Engine Cover.....	98
Adjustable Gauge Undercarriage Frame.....	91
Expanding the Undercarriage and Retracting the Undercarriage.....	91

B

Battery - Recycle.....	110
Battery Electrolyte Level - Check.....	110
Battery Hold-Down - Tighten.....	110
Battery or Battery Cable - Inspect/Replace....	110
Battery Recycle.....	111
Checking the Battery Electrolyte Level.....	111
Checking the Battery Gas Drainage Hose.....	111
Before Operation.....	23, 48
Before Starting Engine.....	22
Belt - Inspect.....	112
Blade Linkage - Lubricate.....	112
Dozer.....	112
Blade Operation.....	85
Increasing the Width of the Stabilizer Blade.....	85
Reducing the Width of the Stabilizer Blade.....	85
Boom, Stick and Bucket Linkage - Lubricate.....	113
Boom, Stick, and Frame - Inspect.....	113
Blade.....	114
Boom.....	114
Lifting Points.....	114
Lower Frame.....	115
Stick.....	114
Upper Frame.....	115
Boom/Stick/Bucket Combinations.....	37
Bucket - Remove and Install.....	82
Installation Procedure.....	83
Removal Procedure.....	82
Bucket Tips - Inspect/Replace.....	115
Bucket Tips.....	115
Burn Prevention.....	17
Batteries.....	18
Coolant.....	17
Oils.....	18

C

Capacities (Refill).....	102
Caterpillar Approved Work Tools.....	140
Coolant System - Flush.....	115
Cooling System Coolant - Change.....	116
Cooling System Coolant Level - Check.....	118
Crushing Prevention and Cutting Prevention..	17

D

Daily Inspection.....	48
Declaration of Conformity.....	45
Work Tool Declaration of Conformity.....	47
Decommissioning and Disposal.....	140

E

Electrical Storm Injury Prevention.....	21
Emissions Certification Film.....	44
Emissions Warranty Information.....	139
Engine Air Filter Primary and/or Secondary Element - Replace.....	118
Engine Air Filter Service Indicator - Inspect...	119
Engine and Machine Warm-Up.....	75
Engine Oil and Filter - Change.....	120
Engine Oil Level - Check.....	120
Engine Oil Sample - Obtain.....	120
Engine Starting.....	23, 75
Engine Starting (Alternate Methods).....	96
Engine Starting with Jump Start Cables.....	96
Engine Stopping.....	27
Engine Valve Lash - Check/Adjust.....	121
Equipment Lowering with Engine Stopped....	28, 78

F

Fasteners - Check.....	122
Film (Product Identification) - Clean.....	122
Cleaning of the Films.....	123
Fire Extinguisher Location.....	21
Fire Prevention and Explosion Prevention.....	18
Battery and Battery Cables.....	19
Ether.....	21
Fire Extinguisher.....	21
General.....	18
Lines, Tubes, and Hoses.....	20
Wiring.....	20
Foreword.....	4

California Proposition 65 Warning	4	Important Safety Information	2
Certified Engine Maintenance	5		
Literature Information	4	J	
Machine Capacity	5	Joystick Controls	69
Maintenance	4	Joystick Controls Alternate Patterns	72
Operation	4	Alternate Joystick Control Pattern	73
Product Identification Number	5	Joystick Control Selector (If Equipped)	73
Safety	4		
Freezing Conditions	88	L	
Frozen Ground Conditions	77	Leaving the Machine	89
Fuel Injection Pump - Clean	123	Lifting and Tying Down the Machine	92
Fuel Injection Timing - Check	123	Lifting the Machine	92
Fuel System - Prime	123	Positioning the Machine for Lifting	92
Fuel System Filter - Replace	124	Tying Down the Machine	93
Fuel System Water Separator - Drain	125	Lifting Capacities	38
Fuel Tank Cap and Strainer - Clean	126	Lifting Objects	27
Fuel Tank Water and Sediment - Drain	126	Light - Test	131
Fuses - Replace	126	Lubricant Viscosities	99
Relays	127	Biodiesel	100
		Coolant Information	101
G		Diesel Fuel Recommendations	100
General Hazard Information	14	Engine Oil	99
Containing Fluid Spillage	16	General Information for Lubricants	99
Dispose of Waste Properly	17	Hydraulic Systems	99
Fluid Penetration	15	Selecting the Viscosity	99
Inhalation	16	Special Lubricants	100
Pressurized Air and Water	15	Lubricant Viscosities and Refill Capacities	99
Trapped Pressure	15		
General Information	33	M	
Guards	31	Machine Operation	50
Guards (Operator Protection)		Machine Storage and Specified Storage	
Other Guards (If Equipped)	32	Period	89
Roll Over Protective Structure (ROPS)	32	Machine Storage	89
		Specified Storage Period	89
H		Main Relief Valve - Check	131
Hammer Operation (If Equipped)	83	Maintenance Access	98
Horn - Test	127	Maintenance Interval Schedule	108
Hydraulic Control Linkage - Lubricate		Every 10 Service Hours or Daily	108
(Joystick Controls Alternate Pattern (If		Every 1000 Service Hours	109
Equipped))	127	Every 2000 Service Hours	109
Hydraulic System - Purge	128	Every 250 Service Hours	108
Hydraulic System Oil - Change	128	Every 3 Years After Date of Installation or	
Hydraulic System Oil Filter (Return) -		Every 5 Years After Date of	
Replace	129	Manufacture	109
Hydraulic System Oil Level - Check	130	Every 500 Service Hours	109
Hydraulic System Oil Sample - Obtain	131	Initial 100 Service Hours	108
		Initial 1000 Service Hours	109
I		Initial 50 Service Hours	108
Identification Information	42	Initial 500 Service Hours	109

When Required.....	108	P	
Maintenance Section.....	98	Parking	27, 87
Maintenance Support.....	103	Plate Locations and Film Locations	42
Monitoring System.....	67	Certification.....	44
Alert Indicators.....	67	Eurasian Economic Union	43
Service Hour Meter.....	68	European Union.....	43
Mounting and Dismounting	48	Product Identification Number (PIN) Plate ..	42
Machine Access System Specifications.....	48	Power Mode (Dual Power Mode).....	58
O		Changeover from Diesel to Hydraulic	
Oil Filter - Inspect	132	Power Pack (HPU) Operation	62
Inspect a Used Filter for Debris	132	Changeover from Hydraulic Power Pack	
Operating Technique Information.....	79	(HPU) to Diesel Operation	61
Digging.....	79	Charging the Battery with the Mains.....	65
Lifting Objects	80	Charging the Battery with the Power pack ..	65
Operating Techniques	79	Checking the Hydraulic Oil Levels of the	
Operation.....	24, 77	Excavator and the Power Pack	61
Critical Failures	24	Coupling the 300.9D VPS *+Excavator to the	
Limiting Conditions and Criteria	24	Power Pack.....	59
Machine Operating Temperature Range.....	24	Manually Charging the Excavator Battery ...	64
Machine Operation	25	Operation with a Beacon in HPU Mode ...	65
Machine Operation when the Machine is not		Uncoupling.....	63
Completely Assembled	26	Prepare the Machine for Maintenance.....	103
Operation Information	77	Product Information Section.....	33
Operating Procedure	77	Product Link	66
Operation Section.....	48	Data Broadcasts	66
Operator Controls.....	51	Operation in a Blast Site for Product Link	
Adjustable Gauge Undercarriage Control		Radios.....	67
(14).....	56	R	
Adjustable Undercarriage Control and Dozer		Radiator Core - Clean	132
Blade Control Selection Lever (6).....	55	Reference Information Section	140
Auxiliary Control Pedal (4).....	55	Reference Material.....	140
Beacon (If Equipped).....	58	Reference Materials.....	140
Boom Swing Control (17)	57	Rollover Protective Structure (ROPS) -	
Dozer Blade Control (14).....	56	Inspect.....	133
Engine Start Switch (16).....	57	Rubber Belt Track Operation.....	86
Governor Control Lever (8).....	55	S	
Horn (3).....	55	S·O·S Information	102
Hydraulic Lockout Control(1).....	53	Safety Messages.....	6
Joystick Controls (9, 13)	56	Aerosol Starting Aid (11).....	12
LED Work Light (19) 300.9D VPS	58	Crushing Hazard (12)	12
Monitoring System (11).....	56	Crushing Hazard (15)	13
Operators Seat (10).....	56	Crushing Hazard (7)	10
Power Outlet (15).....	56	Crushing Hazard (8)	11
Swing Lock Pin Control (12)	56	Do Not Operate (1)	7
Travel Controls (2).....	53	Do Not Weld or Drill on ROPS (6)	10
Work Light Switch (18) 300.9D.....	57	Electrical Power Lines (13).....	12
Work Tool Flow Mode Control (7) (If		High Pressure Cylinder (16)	13
Equipped).....	55		
Operator Station	31		

Hot Surface (10)	11	System Pressure Release.....	105
Jump Start Cables (17).....	14	Coolant System	105
Machine Operation (3).....	8	Hydraulic System.....	105
Pressurized System and Crushing Hazard (5).....	9	T	
Relieve Hydraulic Tank Pressure (4).....	9	Table of Contents	3
Remove Before Transport (18).....	14	Towing Information	95
Rotating Parts Hazard (14).....	13	Towing the Machine.....	95
Unexpected Machine Movement (2)	8	Track Adjustment - Adjust	136
Unexpected Machine Movement (9)	11	Loosening the Track	136
Safety Section	6	Tightening the Tracks	136
Seat	50	Track Adjustment - Inspect.....	137
Seat Belt	50	Measuring Rubber Track Tension	137
Seat Belt Adjustment for Retractable Seat Belts (Machines equipped with ROPS)	50	Track Information	21
Seat Belt - Inspect	133	Transportation Information	90
Seat Belt - Replace	133	Travel Alarm - Test	137
Service Interval Chart.....	103	Travel in Water and Mud	80
Shipping the Machine.....	90	Procedure for Removing the Machine from Water or Mud	81
Loading The Machine	90	U	
Unloading The Machine.....	90	Undercarriage - Check	138
Slope Operation	28	Undercarriage - Inspect.....	138
Sound Information and Vibration Information.....	29	V	
Sound Level Information.....	29	Visibility Information	22
Sound Level Information for Machines in Eurasian Economic Union Countries.....	29	Restricted Area	22
Sound Level Information for Machines in European Union Countries and in Countries that Adopt the “EU Directives”	29	Visual Inspection	138
Sources.....	31	W	
“The European Union Physical Agents (Vibration) Directive 2002/44/EC”	29	Warranty Information.....	139
Sound Suppression (Covers, Panels) - Inspect/Replace.....	134	Warranty Section	139
Specifications	33	Welding on Machines and Engines with Electronic Controls	107
Engine.....	37	Window (Front) (If Equipped)	68
Expected Life	33	Windows - Clean	138
Intended Use	33	Soap and Water	138
Specification Data.....	34	Work Tool Control.....	70
Working Ranges	36	Auxiliary Hydraulic Circuit.....	70
Stopping the Engine	88	Hydraulic Hoses and Coupler Assemblies (If Equipped).....	71
Stop the Engine if an Electrical Malfunction Occurs.....	89	Work Tool Pedal (One-Way Flow)	71
Stopping the Machine.....	87	Work Tool Pedal (Two-Way Flow)	72
Storage and Literature Compartment	68	Work Tools.....	23
Swing Bearing - Lubricate	134		
Swing Frame and Cylinder Bearings - Lubricate	134		
Swing Gear - Lubricate.....	135		
Swing Motor and Swing Gear - Check	136		

Product and Dealer Information

Note: For product identification plate locations, see the section "Product Identification Information" in the Operation and Maintenance Manual.

Delivery Date: _____

Product Information

Model: _____

Product Identification Number: _____

Engine Serial Number: _____

Transmission Serial Number: _____

Generator Serial Number: _____

Attachment Serial Numbers: _____

Attachment Information: _____

Customer Equipment Number: _____

Dealer Equipment Number: _____

Dealer Information

Name: _____ Branch: _____

Address: _____

Dealer Contact

Phone Number

Hours

Sales: _____

Parts: _____

Service: _____



SEBU8740
©2020 Caterpillar
All Rights Reserved

CAT, CATERPILLAR, LET'S DO THE WORK, their respective logos, "Caterpillar Yellow", the "Power Edge" and Cat "Modern Hex" trade dress as well as corporate and product identity used herein, are trademarks of Caterpillar and may not be used without permission.